

Chapter

7

Signs

- 7.1 Purpose
- 7.2 Applicability
- 7.3 Definitions
- 7.4 Sign Table
- 7.5 Prohibited Signs
- 7.6 Exempt Signs
- 7.7 General Sign Regulations
- 7.8 Regulations by Sign Type
- 7.9 Additional Standards
- 7.10 Regulations by Use
- 7.11 Exceptions and Modifications
- 7.12 Political Signs Procedure
- 7.13 Required Landscaping
- 7.14 Permit Procedure
- 7.15 Maintenance of Signs
- 7.16 Nonconforming Signs
- 7.17 Relocation of Signs
- 7.18 Obsolete or Abandoned Signs
- 7.19 Non-Commercial Copy Permitted on Any Authorized Sign
- 7.20 Appeals and Validity

7.1. PURPOSE

It is the purpose of this Chapter to promote the general welfare and appearance of the Town of Elkin by setting standards for the type and placement of signs. The purpose of this Chapter is, therefore:

- A.** To preserve the scenic, natural environment by allowing signs which are consistent with an attractive town appearance and promote the general welfare of the Town of Elkin.
- B.** To provide for the safety of vehicular and pedestrian traffic by limiting visual and physical interference.
- C.** To protect the general public from injury caused by distracting and/or improperly placed signs.
- D.** To protect property values and promote the economic welfare of Elkin by encouraging visually appealing, consistent, and clear forms of information transfer.

7.2. APPLICABILITY

This Chapter shall apply to all signs located within the Town of Elkin and its extraterritorial jurisdiction unless prohibited as per Section 7.4. or 7.5.

7.3. DEFINITIONS

A sign is any device, structure, fixture, painting, emblem, or visual that uses words, graphics, colors, illumination, symbols, numbers, or letters for the purpose of communicating a message. A sign includes all poles, frames, and other supports upon which such display is made.

ABANDONED SIGN. A sign which has not identified or advertised a current business, service, owner, product, or activity for a period of at least one hundred and twenty (120) days.

ATTACHED WALL SIGN. A sign which is mounted flush or near flush and parallel to a vertical building wall. Wall signs shall be attached throughout their entire length and shall not extend above the highest vertical point of the building to which they are attached.

AWNING SIGN. A sign which consists of copy on the front and/or side of a shelter projecting from and supported by the exterior wall of a building constructed of non-rigid materials, such as fabric, flexible plastic, cloth, on a supporting framework.

BANNER SIGN. A sign with copy on a non-rigid material such as cloth, plastic, fabric, or paper with no or minimal framework. Banners are temporary in nature and do not include flags of governmental entities.

BILLBOARD. An outdoor sign displaying a non-commercial message or identifying, advertising and/or directing the public to a business, merchandise, service, entertainment, or product which is unrelated to the place, use of, products sold on, or sale or lease of the property on which such sign is located. These signs are also known as off-premise or outdoor advertising signs.

BULLETIN BOARD. A flush mounted attached wall sign with a frame, which may or may not contain glass or clear plastic showcasing printed information.

CANOPY SIGN. A sign which is suspended from or attached to the top, sides, front, or underside of a permanent, multi-sided structure, attached to a building or any other free-standing structure, that may have roof supports but no walls, for the purpose of providing shelter to patrons or automobiles, or as a decorative feature on a building wall.

CHANGEABLE COPY. The sign copy (text) which may be changed manually by placement of individual letters, numbers, and symbols, digitally or electronically. Digital or electronic changeable copy signs are referred to as electronic message centers.

CONSTRUCTION SIGN. Signs which identify firms and/or builders and which are erected on the premise of the construction site during the period of construction.

DIRECTIONAL SIGN. Signs designed to provide direction to pedestrian and vehicular traffic into and out of or within a site (e.g., in/out, do-not-enter, entrance/exit).

DIRECTORY SIGN. A sign listing the names of more than one business, activity or professional office conducted within a building, group of buildings, or commercial center.

ELECTRONIC MESSAGE CENTER. An electronically or digitally activated changeable copy sign whose variable message and/or graphic presentation capability can be electronically or digitally programmed.

FENCE WRAP. A fabric screen placed over, around, or on top of a chain link construction fence to provide screening, privacy, and/or wind block to a construction site.

FREESTANDING SIGN. A sign supported by a sign structure placed in the ground and which is wholly independent of any building, fence, vehicle, or object other than the sign structure for support.

GASOLINE PUMP SIGN.A sign normally associated with the sale of gasoline and related information contained on the pump.

HOME OCCUPATION SIGN.A sign permitted in association with a legitimate home occupation conducted on the premises of the dwelling unit occupied by the operator of the business.

ILLUMINATION.A source of any artificial or reflected light, either directly from a source of light incorporated in or indirectly from an artificial source.

EXTERNAL ILLUMINATION. Artificial light located away from the sign which lights the sign. The light source may or may not be visible to persons viewing the sign from any street, sidewalk, or adjacent property.

INTERNAL ILLUMINATION. A light source that is concealed or contained within the sign and becomes visible in darkness through a translucent surface. Electronic message center signs, digital displays, and signs incorporating neon lighting shall not be considered internal illumination for the purposes of this ordinance.

BACK-LIT ILLUMINATION. A sign using a three-dimensional message, logo, etc., which is lit in a way to produce a halo effect.

INCIDENTAL SIGN.A sign, generally informational, that has a purpose secondary to the use of the lot on which it is located and is displayed for the direction or convenience of the public. This shall include signs for public rest rooms, telephones, vehicle inspection, credit cards accepted, and hours of operation. No sign with a commercial message legible from a position off the lot on which the sign is located shall be considered incidental.

INTERIOR SIGN. Signs that are located within a building or structure that are illuminated and are not visible to the outside and/or are not intended to be visible to the outside of the structure or building.

MARQUEE SIGN. A sign attached to a covered structure projecting from and supported by a building with independent roof and drainage provisions and which is erected over a doorway or doorways of a theater, auditorium, fairground, or museum as protection against the weather, which advertises present and scheduled events.

MOBILE BILLBOARD. Any vehicle or trailer containing or attached to an advertising sign which is driven and/or parked with the express intent to advertise a product, business, or activity not associated with the vehicle's primary use. This shall not include business logos, identification, or advertising on registered vehicles used for other business purposes and considered vehicular signs.

MURAL. See Painted Wall Sign.

OCCUPANT/STREET NUMBER SIGN. A sign bearing only the name of the principal occupant of a residence or street number of any residential, commercial, or other structure.

ON-PREMISES SIGN. A sign whose message and design directs attention to a business, profession, commodity, service, event, entertainment, opinion, or other commercial or non-commercial activity, sold, offered, or conducted upon the premises where such sign is located.

PAINTED WALL SIGN. A sign painted directly on any exterior building wall or door surface, exclusive of window and door glass areas. Also referred to as a “Mural.”

PORTABLE SIGN. Any sign designed or intended to be readily relocated. This shall include signs on wheels, trailers, truck beds, A-frames, or any other device which is capable of, or intended to be moved, from one location to another.

POLITICAL SIGN. Any sign that advocates for political action and as regulated by N.C.G.S. § 136-32.

PROJECTING SIGN. A double-sided sign which is attached to a building wall with the face of the sign perpendicular to the building wall. Such signs shall not project into any street right-of-way and shall be at least eight (8) feet above the ground.

REAL ESTATE SIGN. A temporary sign which advertises the sale, lease, rental, or auction of the property on which said sign is located.

SANDWICH BOARD SIGN. A type of freestanding, portable, temporary sign consisting of two changeable-copy (chalkboard, whiteboard, cork, or contains clips to attach poster board) faces, connected and hinged at the top and whose message is targeted to pedestrians. Also known as an “A-frame sign.”

SEASONAL DECORATIONS. Signs or displays including illumination which are a non-permanent installation celebrating national, state, and local holidays, religious or cultural holidays, or other holiday seasons. Illumination shall be static; flashing, blinking, or strobing lights are prohibited.

STREET POLE BANNER. A banner suspended above a public sidewalk or right-of-way and attached to a single street pole. These signs may be used at the discretion of the Town and may not contain any commercial advertisement except for a sponsoring organization's logo.

TEMPORARY SIGN. A sign or advertising display constructed of cloth, canvas, fabric, plastic, paper, plywood, or other light material to be displayed for a short period of time, not to exceed thirty (30) days at any given time and to be removed after the purpose has been served.

TIME AND TEMPERATURE SIGN. Electronic signs which display time and temperature.

VEHICULAR SIGN. A sign or advertisement placed or wrapped on an operational, registered vehicle having a principal business use, by owner or lessee, which directs attention to the specific business or product of said owner or lessee.



Figure 7.1
Examples of Signs, Including
Projecting Signs, Street Pole Banners,
Wayfinding Signs, and Window Signs.

WARNING SIGN. An on-premise sign regulating the use of the premises which are placed to inform the public of private regulations such as trespassing warnings or prohibited parking areas.

WAYFINDING SIGN. A sign which is located off-premise and indicates the location of public buildings, parks, schools, churches, hospitals, and scenic or historic places.

WINDOW SIGN. Any sign that is applied, painted, or affixed to a window, or placed inside a window, within three (3) feet of the glass, facing the outside of the building, and easily seen from the outside. Customary displays of merchandise or objects and material without lettering behind a store window are not considered signs.

7.4. SIGN TABLE

Figure 7.2, shows which districts allow each sign type. Signs shown with a “P” are allowed but require a permit. Those shown with an “E” are exempt from a permit requirement, provided the standards for the sign type and/or district are met. An “R” designation means that the sign requires registration. Signs listed with either an “E/P” or an “E/R” designation, are exempt only if they meet certain standards but will require a permit or registration in other instances as noted. Signs which show a “-” (dash) are not permitted in the districts listed.

**Figure 7.2
Sign Table**

Sign Type	LDR, MDR, HDR, HDMF, MH	HB	NB	RF	DMX	MA / M1/M2
STRUCTURE MOUNTED						
1. Wall Sign	-	P	P	P	P	P
2. Awning or Canopy Sign	-	P	P	P	P	P
3. Banner Sign – Temporary	-	P	P	P	P	P
4. Government Sign	E	E	E	E	E	E
5. Historical Marker	E	E	E	E	E	E
6. Interior Sign	E	E	E	E	E	E
7. Mural	-	-	-	P	P	-
8. Menu/Bulletin Board	P	E/P	E/P	E/P	E/P	E/P
9. Incidental Sign	E	E/P	E/P	E	E	E/P
10. Projecting Sign	-	P	P	P	P	P
11. Window Sign	-	P	P	P	P	-
12. Marquee Sign	-	P	P	P	P	-
13. Tenant/Directory Sign	-	E/P	E/P	E/P	E/P	E/P
14. Professional/Occupant Sign	E/P	-	E/P	E/P	E/P	E/P
SITE INSTALLED						
15. Monument Sign: Single Tenant	-	P	P	P	-	P
16. Monument Sign: Multi-Tenant	-	P	P	P	-	P
17. Freestanding/Pole Sign	-	P	P	P	-	-
18. Political Sign	E	E	E	E	E	E
19. School/Civic Sign	P	P	P	P	P	P
20. Menu Board (Drive-thru)	-	P	P	P	P	-
21. Flagpole	E	E	E	E	E	E
22. Government Sign	E	E	E	E	E	E
23. Historical Marker	E	E	E	E	E	E
24. Changeable Copy Sign	P	P	P	P	P	P
25. Sandwich Board - Temporary	-	P	P	P	P	-
26. Directional	-	E/P	E/P	E/P	E/P	E/P
27. Vehicle Sign	-	E	E	E	-	E
28. Limited Duration: For Sale/Construction	E/R	R	R	R	R	R
29. Temporary	E/R	R	R	R	R	R
Legend: P = Sign Allowed / Permit required E = Exempt E/P = Exempt but if does not meet requirements, may be allowed with a permit R = Registration Required E/R = Exempt but if does not meet requirements, may be allowed with registration - = Not Permitted						

7.5. PROHIBITED SIGNS

The following signs are prohibited in the Town of Elkin and in its extraterritorial jurisdiction:

- A.** Any sign which imitates or in any way approximates official highway signs or which obscures a sign displayed by a public authority.
- B.** Any sign, decoration, or illumination, which displays flashing, blinking, or intermittent lights or lights of changing intensity. Any sign which flashes, rotates, spins, revolves oscillates, moves, or has moving parts, including those that inflate or are attached to blowers or fans.
- C.** Any sign which emits smoke, visible vapors or particles, sound, or odor.
- D.** Signs which obstruct driver vision of any vehicle entering a roadway from any street, alley, driveway, or parking lot.
- E.** Signs, floodlights, or other sign illumination which cause glare that impairs driver vision on a roadway or causes a nuisance to adjacent property.
- F.** Signs within or any portion thereof that extends into a public right-of-way or within ten (10) feet of the edge of pavement if no right-of-way is recorded.
- G.** Signs within thirty-five (35) feet of an intersection.
- H.** Any sign, flyer, or other attachment on public utility poles, telephone poles, trees, rocks, fences, benches and refuse containers, except for those placed by the Town. Benches and refuse containers may display a logo. This does not apply to signs placed as sponsorship on fencing within an athletic facility, provided the sign(s) face the playing field, are not visible from any adjacent right-of-way, and are maintained.
- I.** Roof signs and sign structures placed on roofs, unless roof is utilized as a permitted gathering space.
- J.** Pavement marking of any kind other than for traffic control.
- K.** Any sign containing information which states or implies that a property may be used for any purpose not permitted under the provisions of this article in the zoning district on which the property to which the sign relates is located. This provision does not apply to billboards.



**Figure 7.3
Prohibited Temporary
Signs Placed Within the
Right-of-Way.**

- L.** Any sign located in such a way as to intentionally deny an adjoining property owner a visual access to an existing sign.
- M.** Billboards and Mobile Billboards, as defined in Section 7.3.
- N.** Any signs which obstruct any fire escape, window, door, or opening used as a means of egress or to prevent free passage from one part of a roof to any other part thereof. No sign shall be attached in any form, shape, or manner as to interfere with an opening required for legal ventilation.
- O.** Any banner or sign of any type suspended across a public street, without the permission of the owner of the property and/or road right-of-way.
- P.** Any sign which violates any provision of any law of the State of North Carolina relative to outdoor advertising.
- Q.** Abandoned signs and any associated supporting structures. Broken or missing panels of a multi-tenant sign.
- R.** Posters, framed or otherwise, attached to a building.
- S.** Window signs or other advertisements placed in more than one (1) window on a building or more than twenty-five (25%) of the window area.
- T.** Any other sign which does not comply with the regulations of this ordinance.

7.6. EXEMPT SIGNS

A sign permit shall not be required prior to the erection, structural repair, alteration, moving, removal, or demolition of any exempt signs in any zoning district in the Town of Elkin. Exempt signs shall conform to the regulations as noted. No exempt sign shall be illuminated, except as provided for herein. Exempt signs shall not be considered in determining total sign area permitted by this Article. However, if a sign exceeds the size or in any other way does not comply with these limitations, it shall be subject to all other provisions in this Ordinance and in some instances may be allowed with a permit or registration as noted in Section 7.4.

7.7. GENERAL SIGN REGULATIONS

A sign permit or registration shall be secured through the Administrator prior to the use, erection, structural repair, alteration, relocation, removal, or demolition of any sign unless exempt by Section 7.4. However, the following regulations shall be observed for all signs in all zoning districts:

A. Location

1. Any sign located along the right-of-way of a state or federal highway shall comply with the more restrictive requirements of the Town or of the state and federal government relating thereto.
2. No sign shall be placed in such a position as to endanger traffic, pedestrians, or cyclists by obscuring the view of or by resembling official street signs or signals because of position, color, or reflective surface.
3. Only street pole banner signs, traffic signs, and similar regulatory notices of a duly constituted governmental body are permitted within a street right-of-way.
4. If a sign is located on a public or private sidewalk, a minimum of four (4) feet of unobstructed sidewalk clearance must be maintained between the sign and any building or other obstruction.
5. Signs shall be permitted within the front yard of a lot.

B. Sign Area

1. The area of a sign shall be construed to include all lettering, wording, and accompanying design and symbols, together with a background, whether open or enclosed, on which they are displayed, but not including any supporting framework and bracing which are incidental to the display itself.

**Figure 7.4
Example of Sign Area**

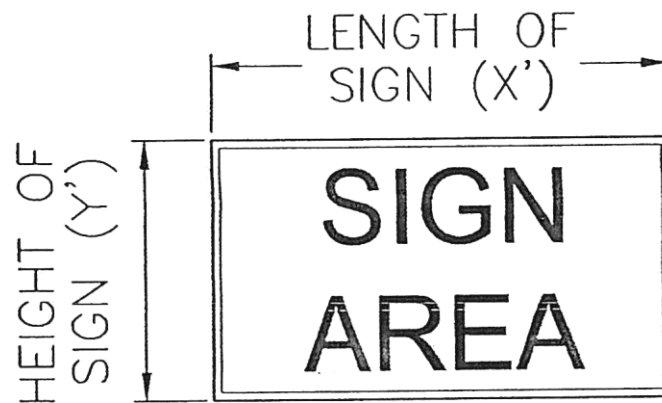

2. Where the sign consists of individual letters or symbols attached to or painted on a surface, building, wall or window, the area shall be the smallest rectangle or other geometric shape which encompasses all the letters and symbols.

Figure 7.5
Example of Sign Area
Individual Letters of Symbols

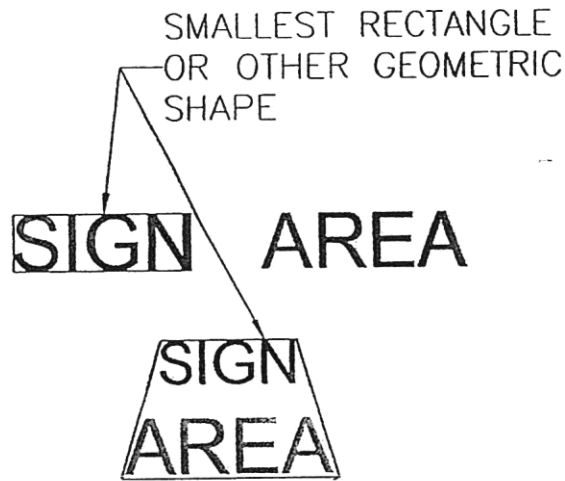

3. In computing the size of a double-faced sign, only one sign face shall be considered, provided that both faces are identical, except where the interior angle formed by the two sides is greater than 45°, in which case both sides shall be counted as part of the sign area.

Figure 7.6
Example of Sign Area
for Double Faced Signs

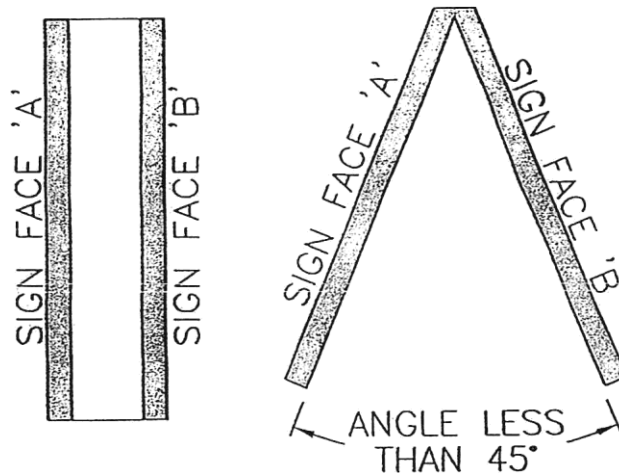

C. Sign Materials and Construction

All signs must be constructed with durable materials, must conform with the requirements of the NC State Building Code, and must be kept in good condition and repair. Signs shall not have broken panels; exposed lighting; peeling, or chipping,

missing or unlit lettering; or support structures that are in disrepair or are an issue of public safety.

D. Sign Height

1. Where a sign projects over a public walkway, the clearance shall be measured as the smallest vertical distance from the lowest edge of such sign to the finished grade of the sidewalk. Clearance shall be at least eight (8) feet.
2. Sign height shall be measured as the distance from the highest point of the sign to the average finished grade of the street closest to the sign. In the case of a sign located greater than one hundred (100) feet from a public street, the height shall be measured to the average grade at the base of the sign.

Figure 7.7
Example of Sign Height
Finished Grade is Less than Base of Sign

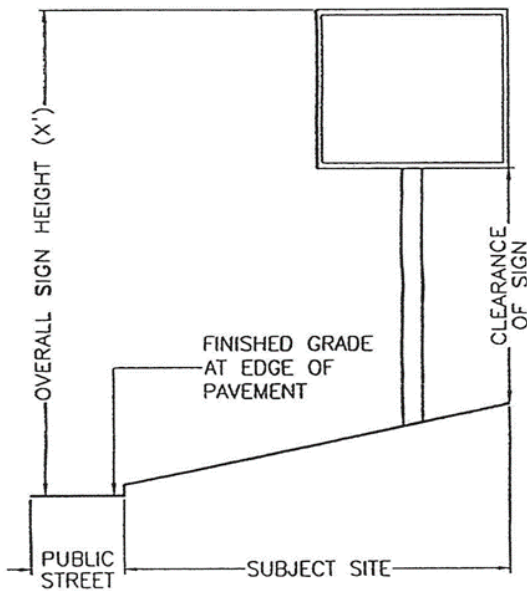
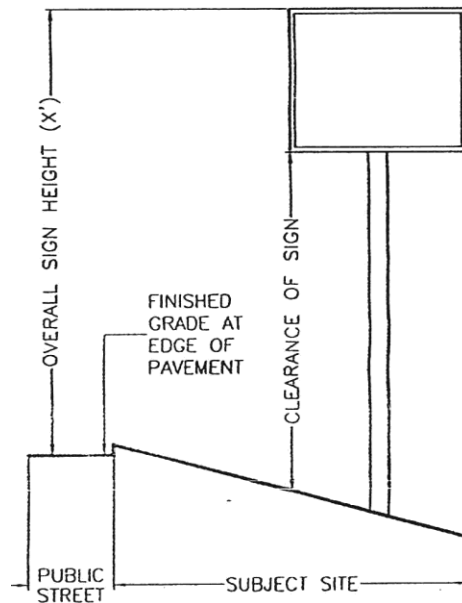

Figure 7.8
Example of Sign Height
Finished Grade is Greater than Base of Sign



3. All signs must be contained within the building height restrictions of the zoning district in which they are located.

E. Number of Signs

Unless otherwise specifically allowed by this article, only one (1) sign per permitted type shall be placed on any one (1) premises, unless such premises fronts on more than one (1) street, in which case one (1) of each permitted sign (excluding freestanding signs) type may be placed on each street frontage. One (1) freestanding sign may be placed on each street frontage if each street is considered arterial or collector, and the

freestanding signs are located no closer than one hundred fifty (150) feet apart. Signs will require a permit or registration, except where specifically exempted by this article.

F. Illumination

1. Light sources shall neither be visible from any street right-of-way nor cause glare hazardous or distracting to pedestrian, vehicle drivers, or adjacent properties.
2. No more than 0.2 foot-candle of light shall be detectable at the boundary of any abutting property.
3. Except for electronic message center signs, signs on non-residential properties may be illuminated from 5:00 a.m. until 11:00 p.m. or one half (1/2) hour past close of business of the facility being used or advertised, whichever is later.
4. Electronic Message Signs shall lower brightness at 11:00 PM by 50% or more of its daytime equivalent.
5. Illumination Types:
 - a. External illumination, where permitted, is allowed only as a steady, stationary light source, shielded, and directed solely at the sign. The light source must be static in color and concealed by a translucent cover.
 - b. Internal illumination and back-lit illumination must be static in intensity, and color. No portion of the light source should be visible.

7.8 REGULATIONS BY SIGN TYPE

The following table gives the regulations and permissions for each sign type based on the district in which the primary use is located.

NOTE: Exempted signs and standards are indicated on the table below. Signs meeting those standards will not require a permit. However, the same sign type in the same district may require a permit to allow for a larger size, illumination, or placement on the lot.

**Figure 7.9
Table of Sign Regulations**

Sign Type	District(s)	Max. Area	Max. Number	Height	Additional Regulations	Illumination
Wall Sign	HB, CB, RF, DMX, MA, M1, M2	15% of the building wall, not to exceed 200 square feet	One (1) per road frontage	N/A	•Mounted greater than 8' from finished grade if projects more than 4".	Back Lit Individual letters of a sign may be channel lit

Sign Type	District(s)	Max. Area	Max. Number	Height	Additional Regulations	Illumination
Awning or Canopy	HB, CB, RF, DMX, MA, M1, M2	Logos or Emblems: Three (3) Square Feet Characters on faces not to exceed 75% of area of awning face.	One (1) per establishment	Minimum clearance shall be eight (8) feet	<ul style="list-style-type: none"> •Must be centered over architectural elements •Shall not be wider than building wall or tenant space •Letters and numbers located only on front and side vertical faces of awning. •Canopy letters and numbers may be placed above, below or on front or side faces. Not to extend above roofline. •Logos or emblems may be on the top or angled portions 	Not Permitted
Banner: Temporary	HB, RF, CB, DMX, MA, M1, M2	Forty (40) square feet	One (1)	N/A	<ul style="list-style-type: none"> •Shall not be displayed more than thirty (30) consecutive days. •No more than two (2) permits per organization per year 	Not Permitted
Menu / Bulletin Boards	Residential, CB, RF, DMX, MA, M1, M2	Exempt: Six (6) square feet Permitted: Twelve (12) square feet	Four (4)	N/A	<ul style="list-style-type: none"> •Mounted flush to the building •Text not intended to be visible from any roadway •May be enclosed in locked, glass case to protect from weather 	Not Permitted If enclosed, case may be internally lit.
Incidental Signs	ALL	Exempt: Two (2) square feet Permitted: Six (6) Square feet	N/A	N/A	<ul style="list-style-type: none"> •Exempt: Building Mounted/Wall •Permitted: Freestanding, attached to structure other than building 	Not Permitted
Projecting Sign	HB, CB, RF, DMX, MA, M1, M2	Twelve (12) square feet	One (1) per establishment	Lowest edge of sign must be at least eight (8) feet above finished grade	<ul style="list-style-type: none"> •No portion may extend more than four (4) feet from the face of the building. •Outermost portion of the signs shall not project into the right-of-way or closer than five (5) from the curb line, whichever is greater. 	Not Permitted
Window Sign	HB, CB, RF, DMX	25% of total window area on front wall face only	N/A	N/A	<ul style="list-style-type: none"> •No rope or string lights •Only first or second floor windows may be utilized for signage •The total area of all window signs may not exceed 25% of the total window area on front wall face only. 	Not Permitted

Sign Type	District(s)	Max. Area	Max. Number	Height	Additional Regulations	Illumination
Marquee	HB, CB, RF, DMX	One (1) square foot of sign area for each linear foot of building frontage	One (1)	The lowest edge shall be at least eight (8) feet above finished grade	<ul style="list-style-type: none"> •Sign shall only be located over principal public entrance. •Must face street or parking lot. •No portion of the sign shall extend vertically above the eave or roof line. •Shall not extend into right-of-way or closer to the curb than three (3) feet, whichever is greater. •Sign shall not be wider than the entrance width plus two (2) feet on each side thereof •Changeable Copy permitted 	Internally lit
Tenant or Directory Sign	HB, CB, RF, DMX, MA, M1, M2	<p>Exempt: Two (2) Square feet per tenant or sixteen (16) square feet total, whichever is greater.</p> <p>Permitted: Up to thirty-two (32) square feet.</p>	One (1) per road frontage	N/A	<ul style="list-style-type: none"> •Exempt: Building mounted •Limited to Business Name and/or Logo 	Exempt: Not Permitted
		<p>Permitted: Freestanding</p> <p>•Limited to Business Name and/or Logo</p>			Permitted: External Illumination (down-lit)	
Professional / Occupant Signs	Residential CB, RF, DMX, MA, M1, M2	<p>Exempt: Three (3) square feet in residential zones. Five (5) in non-residential.</p> <p>Permitted: Ten (10) square feet</p>	Residential: One (1) sign per address	N/A	N/A	Exempt: Not Permitted
		Non-residential: Two (2) signs per address	Permitted: External Illumination			

Sign Type	District(s)	Max. Area	Max. Number	Height	Additional Regulations	Illumination
Monument Sign: Single Tenant	HB, CB, RF, MA, M1, M2	Residential, HB, CB, RF: Forty (40) square feet MA, M1, M2: Eighty (80) Square Feet:	Two (2) per development	Eight (8) Feet	<ul style="list-style-type: none"> •Residential Monument Signs are permitted ONLY at the entrance to a residential development. •Sign shall be located a minimum of ten (10) feet from the right-of-way. •May incorporate changeable copy in any non-residential district. •Sign may be freestanding or attached to a decorative wall. •Base must be landscaped •Similar in style to the architecture and materials of the building façade •Must contain number of street address 	Externally Lit
Monument Sign: Multi-Tenant	HB, CB, RF, MA, M1, M2	One hundred twenty (120) square feet. Each tenant: Eight (8) square feet	One (1) per establishment	Ten (10) feet	<ul style="list-style-type: none"> •Sign shall be located a minimum of ten (10) feet from the right-of-way. •Additional signage may be permitted if more than one (1) street frontage, if other permitted signage reduced. •Base must be landscaped •Similar in style to the architecture and materials of the building façade •Must contain number of street address 	Externally lit
Freestanding / Pole Sign	HB, CB, RF, DMX,	HB - Multi-Tenant: Two hundred fifty (250) sf HB – Single Tenant: Eighty (80) square feet CB: Fifty (50) square feet RF/DMX: (20) square feet	One (1) sign per development. Two (2) signs may be permitted with secondary road frontage when second sign area is reduced by 50% or more.	HB: Thirty (30) feet CB: Twenty (20) feet RF/DMX: Ten (10) feet	<ul style="list-style-type: none"> •Must be located on premises. •Must be set back no less than ten (10) feet from the right-of-way or height of sign, whichever is greater. •May not interfere with traffic •May have changeable copy •Must contain number of street address 	Internally Lit
Political Sign	ALL	Exempt: Four (4) square feet	N/A	N/A	<ul style="list-style-type: none"> •Must comply with N.C.G.S. § 136-32 and with Section 7.12. 	Not Permitted
School / Civic Sign	ALL	Twenty (20) square feet	One (1) per road frontage	Eight (8) Feet	<ul style="list-style-type: none"> •Changeable Copy Permitted 	Internally or Externally Lit

Sign Type	District(s)	Max. Area	Max. Number	Height	Additional Regulations	Illumination
Menu Board (Drive-Thru)	HB, CB	Thirty-two (32) square feet	One (1) per drive-thru lane	Eight (8) Feet	<ul style="list-style-type: none"> • <u>Must be accessory to a permitted drive-thru use</u> • Located in rear yard only • Must not be visible from any right-of-way 	Internally Lit, Digital Screen
Changeable Copy Sign	All Non-Residential Districts.	Twelve (12) square feet	One (1) per road frontage	Eight (8) Feet	<ul style="list-style-type: none"> • May be an Electronic Message Center (See Section 7.9.A.) • May be incorporated with another sign type (marquee, monument, school / civic use. freestanding) 	Non-Residential: Externally lit, electronic as permitted in Section 7.7.F.
Sandwich Boards Temporary	RF, DMX, HB, CB	Eight (8) Square feet	One (1) per establishment	N/A	<ul style="list-style-type: none"> • Must be constructed of metal or wood. No plastic signs permitted. • Placed on the sidewalk in front of restaurant establishment. • Must be removed each day at close of business • Must maintain a width of five (5) feet of pedestrian clearance around the sign. 	Not Permitted
Directional	HB, CB, RF, DMX, MA, M1, M2	Exempt: Four (4) square feet	Two (2) per entrance/exit.	Four (4) feet	<ul style="list-style-type: none"> • Must not be placed in the site-triangle or interfere with traffic. • Set back at least five (5) from the edge of the right-of-way. • Limited to two (2) per entrance/exit. 	Exempt: Not Permitted
		Permitted: Eight (8) square feet				Permitted: Internally Lit
Vehicle Signs	HB, CB, RF, MA, M1, M2	N/A	One (1) per vehicle	N/A	<ul style="list-style-type: none"> • The vehicle shall be parked in a standard parking space on commercial property only. • Limited to standard single, rear-axle car, truck, or van. No tractor-trailer, step-vans, or oversized vehicles. • Must possess current and valid license tag, insurance, and inspection sticker. • Vehicle must operate and be moved every ten (10) days. • All advertisement / text / logos shall be permanently affixed, wrapped, or painted to vehicle. 	Not Permitted

Sign Type	District(s)	Max. Area	Max. Number	Height	Additional Regulations	Illumination
Limited Duration: For Sale / Construction	ALL	Residential Real Estate: Six (6) square feet Non-residential Real Estate or Construction: Thirty-two (32) square feet	One (1) per street frontage	Ten (10) feet	<ul style="list-style-type: none"> Registered for period of six (6) months. May be renewed a total of three (3) times. Residential For Sale Signs shall be Exempt but must meet requirements of this Chapter. 	Not Permitted
Temporary	ALL	Exempt: Three (3) square feet Register: Eight (8) square feet	<ul style="list-style-type: none"> One (1) temporary sign per road frontage, per site. 	Four (4) feet	<ul style="list-style-type: none"> Must be placed on-premises only or have property owners written permission. Shall not be located with a public right-of-way. May not be displayed for more than thirty (30) consecutive days Limited to four (4), thirty (30) day registration periods per twelve (12) month period. No less than thirty (30) days may separate those periods. Temporary signs must be permitted sign types. 	Not Permitted

7.9 ADDITIONAL STANDARDS

A. Electronic Message Center Sign

1. Electronic message center signs are permitted in the form of freestanding and wall signs or incorporated as a portion of a freestanding or wall sign. If used as a wall signs, they shall be included in the total permitted sign area. Electronic message centers are permitted instead of or as part of and shall not be permitted in addition to a freestanding or wall sign on a property.
2. Only one (1) message center sign is permitted per property, regardless of the number of street frontages.
3. Audio speakers and/or any form of pyrotechnics are prohibited.
4. Any portion of the message must have a minimum duration of ten (10) seconds and must be a static display. Messages may change immediately or fade in and out only. No portion of the message may flash, scroll, twirl, twinkle, oscillate, rotate, blink, change color, or in any manner imitate movement. Video is prohibited.
5. Time and temperature shall be included as a separate message(s).

6. The illumination and/or intensity of the display shall be controlled to avoid glare, hazards, or nuisances. The brightness of the digital sign shall not exceed 0.3 foot-candles of light above the normal ambient light levels. Such signs shall be equipped with automatic dimming technology which adjusts the sign's brightness based on ambient light conditions.
 - a. The luminance specification shall be determined by a foot-candle metering device held at a height of five feet and aimed towards the sign from a distance of sixty-five (65) feet.
 - b. The metering device should be at a location perpendicular to the sign's center (as seen in plan view) as this angle has the highest luminance.
 - c. This check shall include the measurement of an all-white image displayed by the sign to evaluate the worst-case condition.
 - d. If the difference in luminance between the sign-on and the sign-off conditions is 0.3 foot-candle or less, then the sign luminance complies.
7. All signs must be equipped with a properly functioning default mechanism that will stop the sign and return to a solid black display should a malfunction occur.
8. Applicant shall be required to coordinate/permit message access for local, regional, state, and national emergency services during emergency situations. Emergency messages are not required to conform to message standards listed herein.

B. Street Pole Banner

Street pole banners that comply with the regulations of this section shall not be included in the determination of the type, number, or area of signs allowed on a property.

1. Illumination of any street pole banner is prohibited.
2. **Area.** Each street pole banner shall have a maximum area of twelve and one half (12.5) square feet and a maximum width of up to three (3) feet.
3. **Number.** Up to two (2) street pole banners are permitted per street pole.
4. **Height.**
 - a. When the street pole banner's edge is less than eighteen (18) inches from the curb, the lowest edge of the street pole banner shall be fourteen (14) feet above the finished grade.
 - b. When the street pole banner's edge is greater than eighteen (18) inches from the curb, the lowest edge of the street pole banner shall be at least eight (8) feet above the finished grade.
5. Street pole banners shall only be permitted and installed by the Town of Elkin or the Department of Transportation.

7.10 REGULATIONS BY USE

A. Entertainment Uses

Theaters, museums, auditoriums, and other entertainment facilities are permitted one changeable copy marquee in addition to their permitted signs. Marquee signs shall conform to the applicable sign requirements for the zoning district in which they are located, however, the area of the marquee sign shall be permitted an increase in size up to an additional one hundred percent (100%) provided that one of the other signs to which the business is entitled is reduced in size. The percentage of increase in area shall be equal to the reduction in area of the other permitted sign.

B. Shopping Centers

A shopping center, mall, PUD, big box retail, or Conditional District (-CD) retail use consisting of two or more businesses in one building, in connecting buildings, or as a unified development shall be permitted a freestanding, directory sign which announces the name of the commercial center and/or establishments within. Directory signs shall be freestanding and shall conform to the requirements as follows as well as those of other sections in this Chapter as they pertain to freestanding signs or the district in which they are located.

1. In the DMX and RF zones, the permitted area of a directory sign shall not exceed fifty (50) square feet in area and ten (10) feet in height.
2. In the HB zone, the permitted area of a directory sign shall not exceed two-hundred-fifty (250) square feet in area and thirty (30) feet in height.
3. In the NB and MA zones, a directory sign shall not exceed the greater of one hundred (100) square feet in area or ten (10) square feet in area for each one-hundred-fifty (150) linear feet of arterial road frontage of the lot on which it is located. The height of the directory sign shall not exceed twenty (20) feet.
4. When the development has frontage in excess of four hundred (400) feet on two (2) or more arterial road(s), consists of more than five (5) acres, and provides more than one (1) site access, one (1) directory sign per arterial road frontage is permitted. However, the second sign shall be clearly incidental and be limited to one hundred fifty (150) square feet in the HB zoning district and fifty (50) square feet in the NB or MA zoning districts.
5. Entrances to interior malls may be identified by an attached sign in addition to the other freestanding signs permitted to the business establishment. Such signs shall be attached to the building over the entrances or besides the entrances

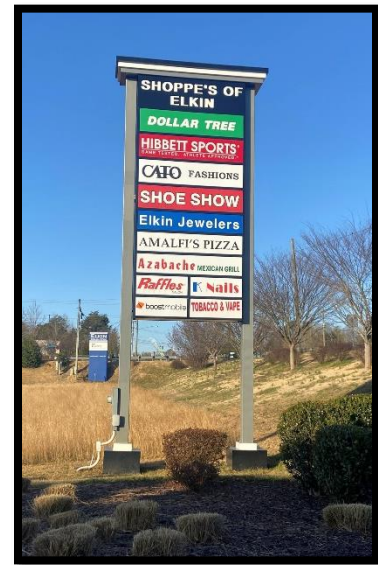

Figure 7.10
Freestanding,
Directory Sign Outside
the Shoppes of Elkin

only. The signs shall not exceed four (4) square feet in the DMX and RF zones or eight (8) square feet in the HB zone.

6. Signs may be internally illuminated.
7. Signs for Tenants within Shopping Centers:

Businesses within shopping centers establishments are permitted two (2) signs from the following categories:

- a. Wall
- b. Canopy
- c. Projecting

C. Drive-thru Uses

Menu signs for Drive-thru restaurants are permitted as either a free-standing sign or an attached wall sign. Such signs may not exceed thirty-six (36) square feet and shall not be visible from the front of the restaurant or adjacent right-of-way. If a free-standing menu sign is used, such sign may not exceed six (6) feet in height. No more than two (2) drive-through menu boards are permitted for each drive-thru restaurant, but in no way shall the total area of menu boards exceed forty-eight (48) square feet.

7.11. EXCEPTIONS AND MODIFICATIONS

A. Business with Only One Sign

Where a business establishment elects to erect only one sign and that sign is to be an attached sign the permitted area of this sign may be increased as follows:

1. The permitted area of an attached sign may be increased by fifty (50) percent.
2. The attached sign permitted by this Section shall meet all other applicable requirements regarding placement, lighting, permit procedures, etc., of this ordinance.
3. If the business should desire a second sign after the attached sign allowed by this Section is erected, no permit for the additional sign shall be issued until the attached sign meets the size requirements of the zone in which it is located as specified in Section 7.8.

B. Portable Signs

It is the intent of this Ordinance to discourage the use of portable signs as defined in Section 7.3.S. However, limited use will be allowed.

1. Portable signs as defined in Section 7.3.S. will need a permit and the permit will be valid for thirty (30) days. Only one (1) portable sign permit, per business, per

quarter, will be issued with a minimum interval of thirty (30) days between permits required.

2. The sign will not exceed twenty-four (24) square feet in area.
3. Only one such sign is allowed per premise in addition to other permitted signs.
4. Portable signs will be permitted in the following zoning districts: HB Highway business, M-1 Light Industrial and M-2, Heavy Industrial.
5. A portable sign, not in use and/or without a valid permit, shall be stored within an enclosed structure or fenced area. No portion of a portable sign shall be visible from any adjacent road or property line.

C. Big Box Retailers

Big Box Retailers larger than fifty thousand (50,000) square feet located on corner lots may be allowed two (2) freestanding signs and one (1) attached sign. Free standing signs may not exceed thirty (30) feet in height. The two (2) free standing signs may not total more than one hundred sixty (160) square feet in surface area, however the maximum limit of any one sign is one hundred twenty-six (126) square feet. The maximum limit for an attached sign is three hundred fifty (350) square feet.

7.12. POLITICAL SIGNS

The following regulations shall apply solely to political signs placed by candidates running for political office during an election year.

- A.** Signs are to be located entirely on private property, outside of any public right-of-way. For the purposes of this Section only and for the benefit of candidates and their campaign staff, the right-of-way is interpreted to be from the ditch line on one side of the road to the ditch line on the opposite side of the road. In cases where the ditch line is not visible, the right-of-way shall be interpreted to be a minimum of 10 (ten) feet from the edge of the pavement on one side of the road to 10 (ten) feet from the edge of pavement on the opposite side of the road.
- B.** Signs shall be located a minimum of thirty-five (35) feet from the intersection of the pavement of two or more roads measured parallel to the road surface.
- C.** No signs shall be placed on public utility poles, telephone poles, or any other sign or sign support structure erected by a duly constituted governmental body.
- D.** Portable signs, as defined in Section 7.3., shall not be allowed for political use.
- E.** Political signs shall not exceed four (4) square feet in size.
- F.** Political signs cannot be erected more than forty-five (45) days before election day and must be removed seven (7) days following the election.

- G.** Only the Administrator or his designee may remove signs placed in violation of these regulations. Removal of a lawfully placed political sign, in accordance with N.C.G.S. § 136-32, may be deemed a misdemeanor.
- H.** The candidate must obtain written permission from property owners before posting signs and will be held responsible for violations, including fines for failure to remove signs within thirty (30) days from the date of the election.

7.13. REQUIRED LANDSCAPING

Freestanding signs shall be placed in a landscaped setting appropriate to the size and scale of the sign and character of the site.

- A.** In no case shall the planted area be less than fifty (50) square feet. The planted area shall not be less than three (3) feet in width and at least the length of the greatest dimension of the sign. Curbing, railroad ties, bricks, decorative fencing, or other vehicle barriers shall be used to enclose the landscape area.
- B.** The planted landscape area shall contain materials such as, but not limited to: vegetative ground covers, perennials, shrubs, ornamental trees, and mulch, but excluding paving and artificial plant materials.
- C.** A sketch plan of the landscaped area with the name, quantity, and spacing of plants shall be presented to the Administrator as part of the sign permit application.

7.14. PERMIT PROCEDURE

No sign shall hereafter be erected, attached, suspended, changed, or relocated until a permit has been issued by the Administrator. Application for a permit shall be made to the Administrator in accordance with the requirements contained herein and in Chapter 9. Each application shall be accompanied by sketch and architectural plans which shall:

- A.** Indicate the proposed site by identifying the property by ownership, location, and use.
- B.** Show the location of the sign on the lot in relation to property lines and buildings, zoning district boundaries, right-of-way lines, and existing signs.
- C.** Show size, character, complete structural specifications, and methods of anchoring and support of the proposed sign(s).
- D.** If warranted, the Administrator may require additional information to determine whether the sign will be erected in conformance with this Ordinance.

7.15. MAINTENANCE OF SIGNS

All sign supports, braces, poles, wires, panels, and anchors thereof shall be kept in good repair. They shall be maintained in safe conditions, free from deterioration, missing parts,

and peeling paint. Any sign not in compliance with these standards shall be deemed a nuisance and the following action may be taken.

- A.** The Administrator shall give written notice to the owner specifying the sign indicated and telling what needs to be done to bring the sign into compliance.
- B.** The owner of the sign shall respond to the notice within two (2) weeks and shall have sixty (60) days to complete said repairs. Additional time shall be granted by the Administrator only upon delay of parts when it has been clearly shown that the parts have been ordered.
- C.** Failure to complete repairs in the specified time shall result in the Administrator causing the sign to be repaired, removed, or altered at the expense of the owner(s). Costs of removal or repair, court costs, and attorney fees incurred by the Town shall be assessed against the owner(s), to be collected by the Town in an action in the nature of a debt.
- D.** In the event of a sign which is damaged more than fifty (50%) percent of its reproduction value, such sign shall be restored or repaired only in compliance with the provisions of this ordinance.

7.16. NONCONFORMING SIGNS

A nonconforming sign does not conform to dimensional, design, locational, or other requirements of this ordinance. The nonconformity may currently exist or result from adoption of this Ordinance or any subsequent amendment. Nonconforming signs that were lawful on the effective date of this ordinance shall be maintained, altered, modified, removed, etc. in conformance with the requirements contained in Section 8.5 of this Ordinance.

7.17. RELOCATION OF SIGNS

Signs for which a sign permit has been issued may be relocated in conformance with the regulations of this article upon notification to the Administrator. Signs which are nonconforming may not be relocated except upon removal of all nonconforming features of the sign.

7.18. OBSOLETE OR ABANDONED SIGNS

- A.** Signs or parts of signs which advertise or pertain to a business, product, service, commodity, event, activity, or purpose which no longer exists or that has not been in use for one hundred and twenty (120) days or more shall be deemed to be an abandoned sign.
- B.** Obsolete or abandoned signs are prohibited and shall be removed by the owner or his agent within one hundred and twenty (120) days of termination of the business, activity, event, etc., except for political signs, which shall be removed within seven (7) days after elections.
- C.** Failure to remove such signs or parts of signs shall result in written notice from the Administrator. Failure to comply with these terms shall result in the sign being removed at the owner's expense. Costs of removal or repair, court costs, and attorney fees incurred by the Town shall be assessed against the owner(s), to be collected by the Town in an action on the nature of the debt.



**Figure 7.11
Abandoned
Sign**

7.19. NON-COMMERCIAL COPY PERMITTED ON ANY AUTHORIZED SIGN

Any sign authorized in this Ordinance is allowed to contain non-commercial copy in lieu of any other copy.

7.20. APPEALS AND VALIDITY

The provisions of Chapter 9 Administration, Bodies, and Procedures shall apply to this sign Ordinance.