



DRIVEWAY PERMIT

City of Kentwood Engineering Department
 4900 Breton Ave SE • P.O. Box 8848
 Kentwood, MI 49518-8848
 Phone: (616) 554-0737 Fax: (616) 698-7118

Permit No.: _____
 Application Date: _____
 Effective Date: _____
 Expiration Date: _____

Contractor & Homeowner Information

Property Address		Lot Number	Subdivision - Plat Name	
Homeowner Name			PP No. 41-18-	
Homeowner Address (Street Name & No.)			Homeowner Phone Number	
City	State	Zip		
Contractor Name			Contractors Phone	
Contractor Address		Contractors Fax	Contractors Cell	
City	State		Zip	

(Miss Dig) 72 hours before digging

Call 1-800-482-7171 (toll free)

Activity	Work Conditions
Driveway Type [] Residential [] Commercial Pavement Type _____ Number Driveway Openings _____ Private Road _____ Sidewalk Linear Feet _____ ft Establish Grade _____ Requested Staking Date _____ Curb & Gutter _____ Culvert Required _____ Culvert Type _____ Number of Flared End Sections _____ Culvert Length _____ ft	[] All work to be done in accordance with the City of Kentwood engineering plan. [X] City of Kentwood Engineering Department to be notified 48 hours in advance of work. [X] Forms to be Checked before concrete is poured. [] Complete restoration of roadway including blacktop to be accomplished same day as opening. [] City of Kentwood to place culvert in ditch. Owner to fill over pipe and build driveway. [] Work to be completed as per attached application. Proper traffic signing to be used.

It is understood that all activity resulting from granting of this permit is to be in accordance with the City of Kentwood specification and conditions either checked or written or stated in the City of Kentwood specifications and conditions for highway permits.

Special Provisions _____

Comments _____

Charges _____

CALL FOR INSPECTIONS PRIOR TO PLACING CONCRETE

Permit Fee Overridden? _____ Issued By _____ Total Permit Fee _____

Payment Method _____ Reference _____ Account _____

RESIDENTIAL DRIVEWAY

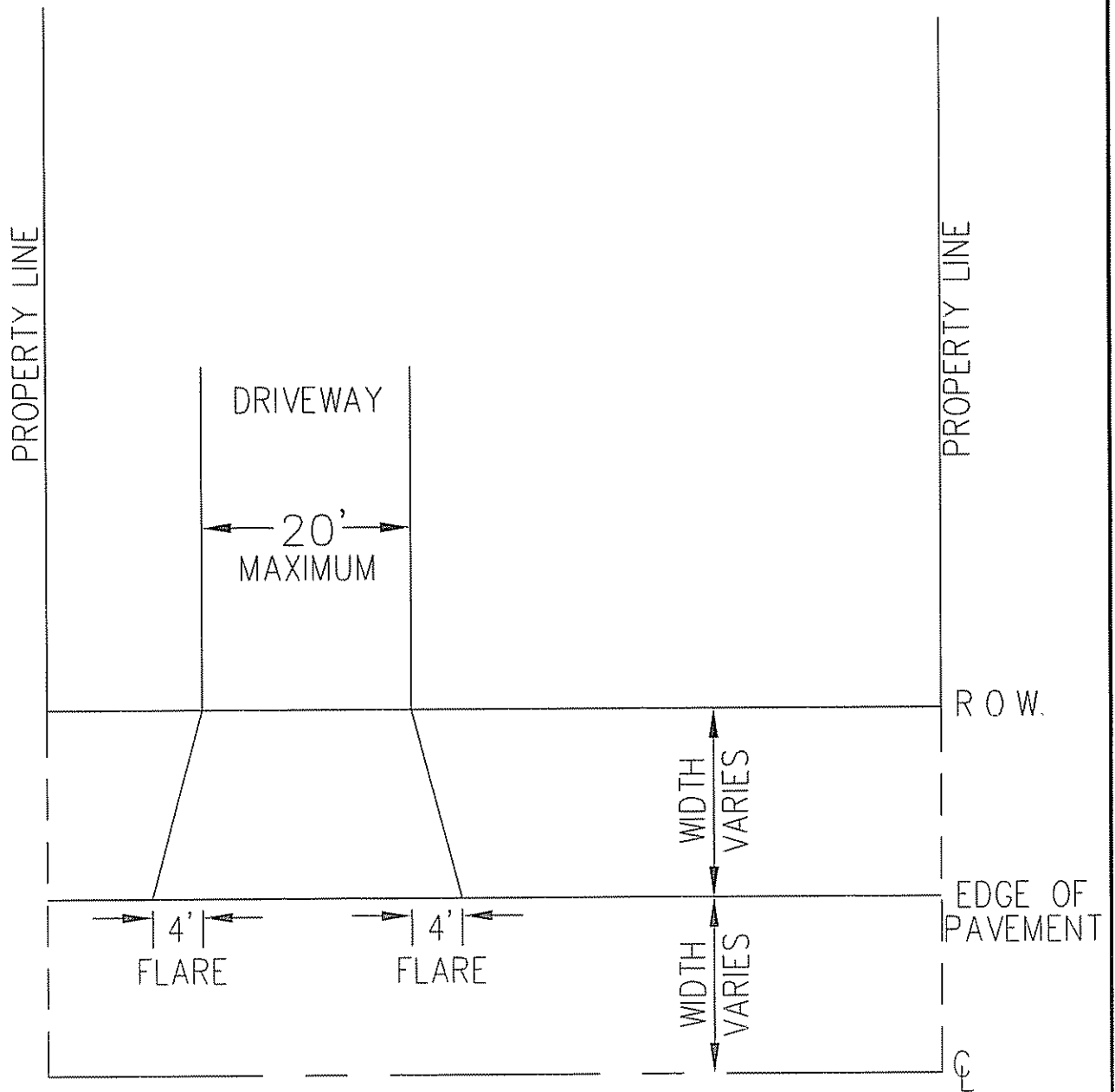

NOTE FLARES MAY NOT CROSS PROPERTY LINES EXTENDED TO CL
NOTE DRIVEWAY AND SIDEWALK CROSSINGS TO BE A MINIMUM OF 6" THICK

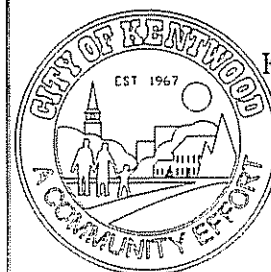

CITY OF KENTWOOD
KENT COUNTY, MICHIGAN

4900 BRETON AVE. S E
KENTWOOD, MICHIGAN 49518-8848

PHONE (616) 698-9610

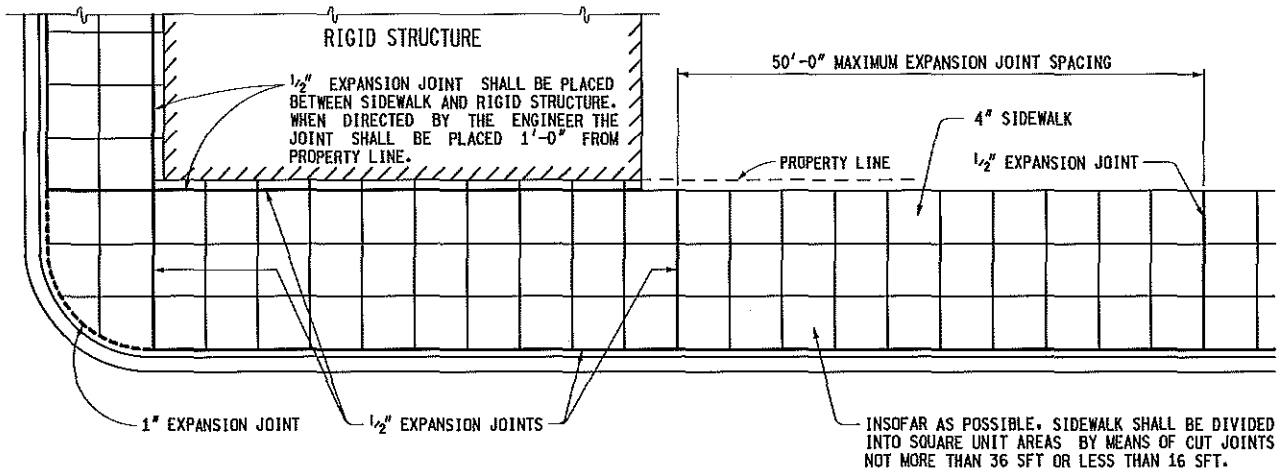
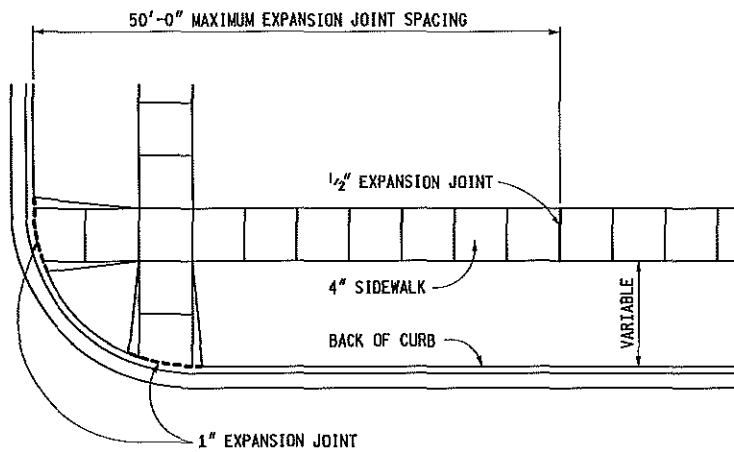

LOCATION OF JOINTS IN CONCRETE SIDEWALK

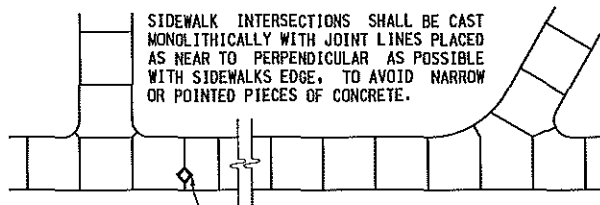

WHERE A PERMANENT STRUCTURE IS LOCATED IN SIDEWALK, PLACE EXPANSION MATERIAL AROUND STRUCTURE AND ADJUST JOINT PATTERN TO INTERSECT STRUCTURE AS ILLUSTRATED.

TYPICAL SIDEWALK JOINT LAYOUTS

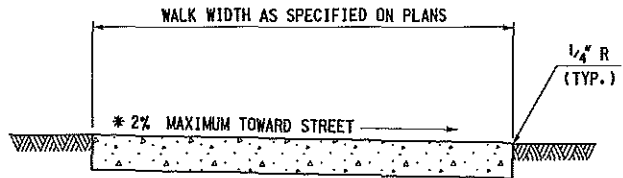

4" CONCRETE SIDEWALK



PREPARED BY
DESIGN DIVISION

DRAWN BY: B.L.T.

CHECKED BY: W.K.P.

DEPARTMENT DIRECTOR
Kirk T. Steudle

APPROVED BY: Randy V. Puffel
DIRECTOR, BUREAU OF FIELD SERVICES

APPROVED BY: Paul A. Van Pelt
DIRECTOR, BUREAU OF HIGHWAY DEVELOPMENT

MICHIGAN DEPARTMENT OF TRANSPORTATION
BUREAU OF HIGHWAY DEVELOPMENT STANDARD PLAN FOR

**DRIVEWAY OPENINGS
& APPROACHES,
AND CONCRETE SIDEWALK**

1-25-2013
F.H.W.A. APPROVAL

10-1-2012
PLAN DATE

R-29-H

SHEET
1 OF 4

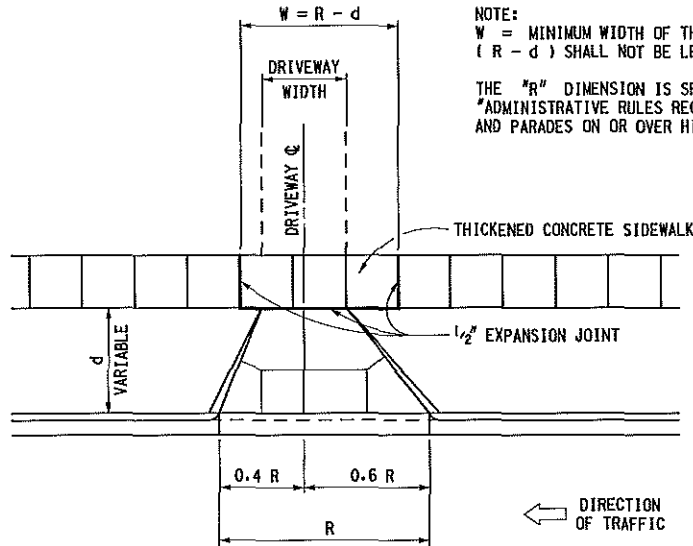

NOTE:
 W = MINIMUM WIDTH OF THICKENED CONCRETE SIDEWALK.
 (R - d) SHALL NOT BE LESS THAN DRIVEWAY WIDTH.

THE "R" DIMENSION IS SPECIFIED IN THE PUBLICATION
 "ADMINISTRATIVE RULES REGULATING DRIVEWAYS, BANNERS
 AND PARADES ON OR OVER HIGHWAYS".

CONCRETE DRIVEWAY OPENING LAYOUT

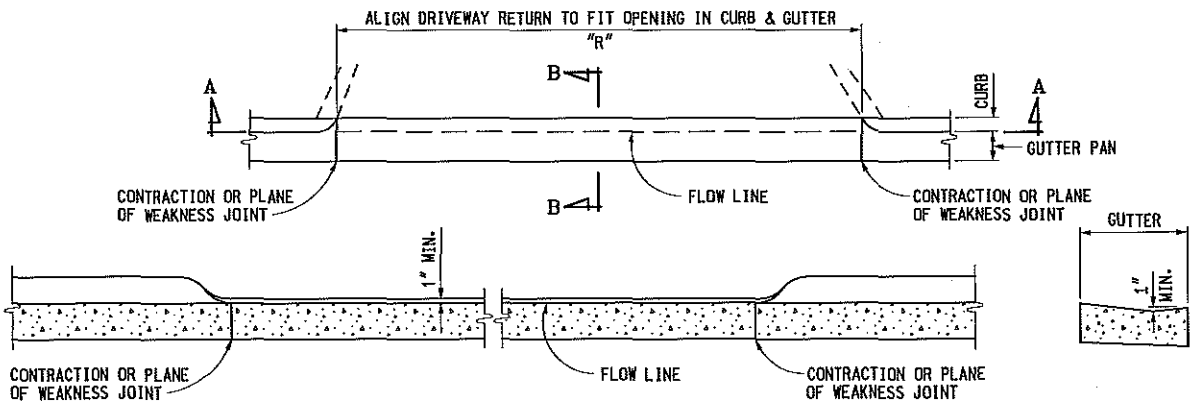

CONCRETE DRIVEWAY OPENING, DETAIL L

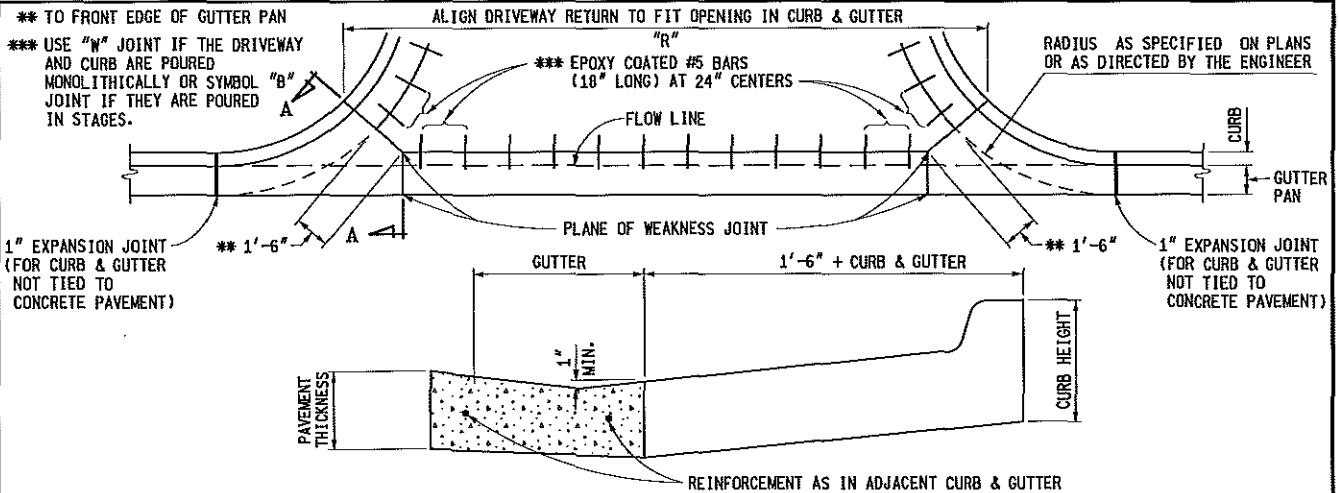

CONCRETE DRIVEWAY OPENING, DETAIL M

NOTE:
 FOR ROADWAYS WITH CONCRETE PAVEMENTS, LONGITUDINAL LANE TIES WILL BE CONTINUOUS THROUGH THE DRIVEWAY OPENING AND THE SPACING OF THE #5 BARS IN CONCRETE DRIVEWAYS SHALL BE ADJUSTED TO AVOID CONFLICT WITH THE LONGITUDINAL LANE TIES.

MICHIGAN DEPARTMENT OF TRANSPORTATION
 BUREAU OF HIGHWAY DEVELOPMENT STANDARD PLAN FOR

**DRIVEWAY OPENINGS
 & APPROACHES,
 AND CONCRETE SIDEWALK**

1-25-2013 F.H.W.A. APPROVAL	10-1-2012 PLAN DATE	R-29-H	SHEET 2 OF 4
--------------------------------	------------------------	--------	-----------------

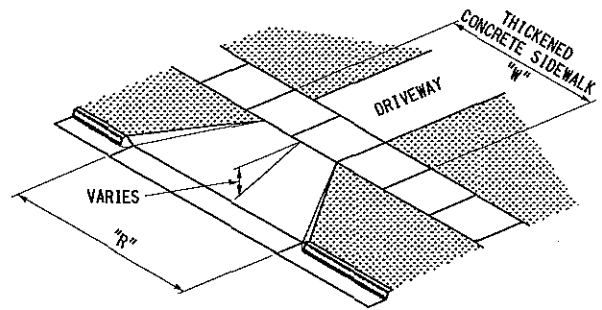
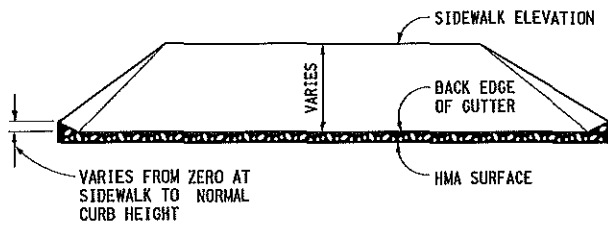

HMA DRIVEWAY APPROACH
(TO BE USED WITH DETAIL L)

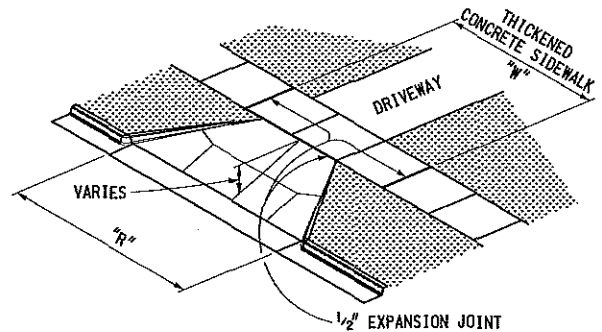
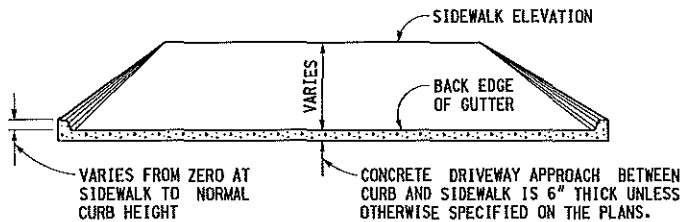

NOTES:
MONOLITHIC CURB IS INCLUDED IN THE CONCRETE DRIVEWAY APPROACH QUANTITY.
REINFORCEMENT IS NOT REQUIRED UNLESS SPECIFIED ON THE PLANS. WHEN REINFORCEMENT IS SPECIFIED, SEE CHART ON THIS SHEET.

CONCRETE DRIVEWAY APPROACH
(TO BE USED WITH DETAIL L OR M)

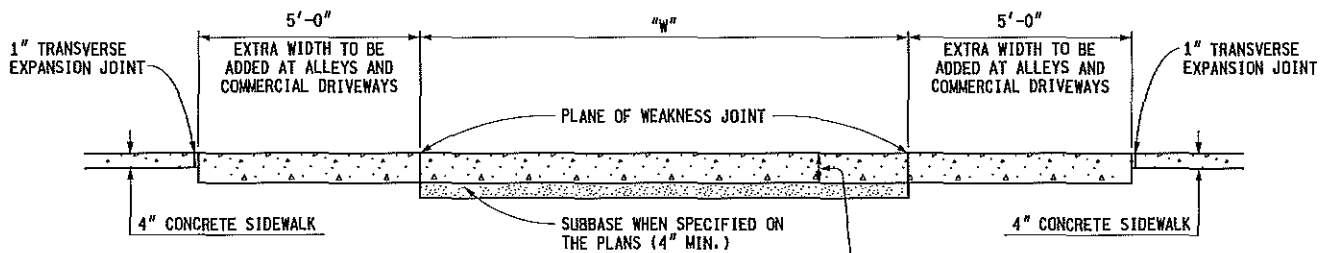

WHEN CONCRETE DRIVEWAY APPROACH IS SPECIFIED, THE THICKENED CONCRETE SIDEWALK THICKNESS IS EQUAL TO THE THICKNESS OF THE CONCRETE DRIVEWAY APPROACH. WHEN HMA DRIVEWAY APPROACH IS SPECIFIED, THE THICKENED CONCRETE SIDEWALK THICKNESS IS 6" MIN.

THICKENED CONCRETE SIDEWALK

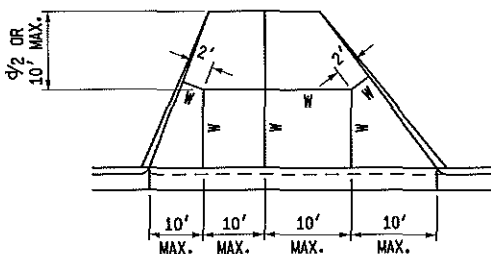

ADJUST DRIVEWAY JOINTS AS NEEDED TO ALIGN WITH ANY COINCIDING TRANSVERSE PAVEMENT JOINTS.

JOINT LAYOUT IS AS INDICATED OR AS DIRECTED BY THE ENGINEER.

INTERMEDIATE DRIVEWAY JOINT DETAILS

REINFORCEMENT FOR CONCRETE DRIVEWAYS

CONCRETE DRIVEWAY THICKNESS	WIRE SIZE (6" x 6" MESH)	AVERAGE WEIGHT (LBS/100 SFT)
LESS THAN 8"	W1.4	21
	W2.9	42
8" OR GREATER	USE WIRE FABRIC REINFORCEMENT SPECIFIED ON STANDARD PLAN R-37-SERIES	

MICHIGAN DEPARTMENT OF TRANSPORTATION
BUREAU OF HIGHWAY DEVELOPMENT STANDARD PLAN FOR

**DRIVEWAY OPENINGS
& APPROACHES,
AND CONCRETE SIDEWALK**

1-25-2013
F.H.W.A. APPROVAL

10-1-2012
PLAN DATE

R-29-H

SHEET
3 OF 4

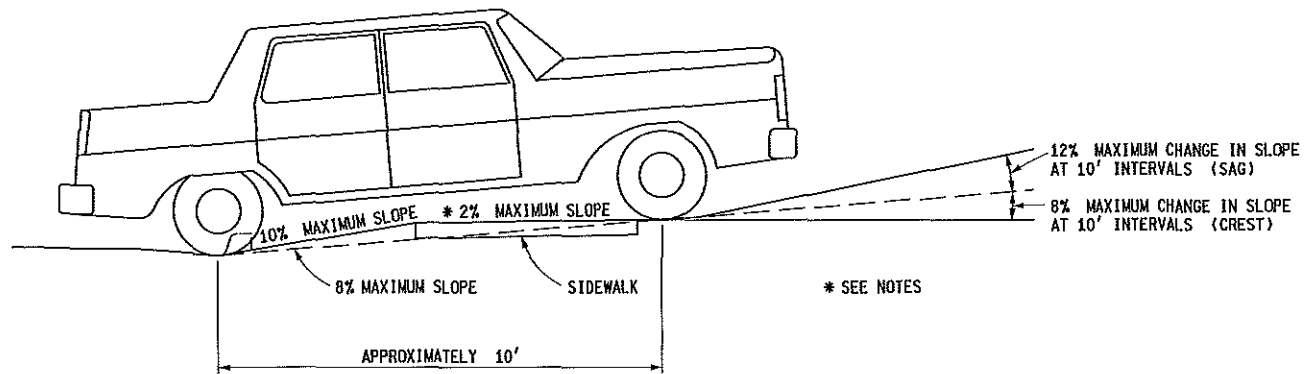

LOW VOLUME COMMERCIAL OR RESIDENTIAL DRIVEWAY SLOPES

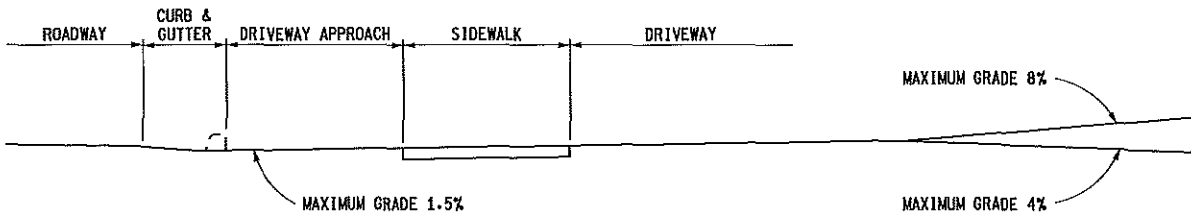

COMMERCIAL DRIVEWAY PROFILE FOR MAJOR TRAFFIC GENERATORS

NOTES:

FOR DRIVEWAY DESIGN REFER ALSO TO "ADMINISTRATIVE RULES REGULATING DRIVEWAYS, BANNERS, AND PARADES ON OR OVER HIGHWAYS" AND GEOMETRIC DESIGN G-680-SERIES, COMMERCIAL DRIVEWAYS.

FOR CURB AND GUTTER DETAILS, SEE STANDARD PLAN R-30-SERIES.

TRANSVERSE SIDEWALK SLOPES ARE TYPICALLY 1.5% OR 2% MAXIMUM. IN ORDER TO MEET SITE CONDITIONS, IF THE TRANSVERSE SLOPE IS REQUIRED TO BE LESS THAN 1.5%, LONGITUDINAL DRAINAGE MUST BE PROVIDED.

WHEN SETTING GRADES FOR COMMERCIAL DRIVES, THE TYPES OF VEHICLES USING THE DRIVE SHOULD BE CONSIDERED.

MICHIGAN DEPARTMENT OF TRANSPORTATION BUREAU OF HIGHWAY DEVELOPMENT STANDARD PLAN FOR DRIVEWAY OPENINGS & APPROACHES, AND CONCRETE SIDEWALK			
1-25-2013 F.H.W.A. APPROVAL	10-1-2012 PLAN DATE	R-29-H	SHEET 4 OF 4



SPECIFICATIONS AND CONDITIONS FOR HIGHWAY PERMITS

Effective May 1, 2024

- 1. Definition of Terms:** Whenever the term City is used in the following specifications it shall mean the City of Kentwood, its employees and officials. The term Engineer shall mean the City of Kentwood Engineer or his authorized representatives. The term Contractor shall refer to the person, firm or corporation undertaking the execution of the work under the terms of the permit.
- 2. Bonds and Insurance:** Surety Company Bonds in the amount of \$20,000.00 conditioned upon performance of the conditions of the permit and these specifications and compliance with all requirements of the law shall be filed with the City each year by contractors desiring to obtain highway permits through the year. Also, a certificate of insurance in the amount of \$200,000.00-\$500,000.00 public liability and \$100,000.00 property damage protecting the City of Kentwood against any and all claims for damages arising from operations covered by the permit shall be filed with the City each year.
- 3. Additional Permits:** When the work involved is in connection with any sewer or water system, this permit is issued contingent on the contractor obtaining the necessary permit from the authorities in control of the system for making the proposed extensions and additions.
- 4. Traffic Protection:** The contractor shall provide, erect, and maintain all necessary barricades, lights, warning signs and flagmen to properly safeguard traffic while this work is in progress. The contractor shall designate a foreman who shall be in responsible charge of the work. The contractor must give the foreman authority to carry out all the provisions contained in these Specifications and Conditions for Highway Permits. If the contractor fails or refuses to carry out these provisions at the time, and in a manner which in the opinion of the Engineer is necessary to protect and direct traffic, or if the contractor cannot be located and notified to do so, the City shall have the right to perform the work and the contractor shall reimburse the City for all charges incurred in the work.
- 5. Interfering Structures:** In case it is necessary to move any building or structure above or below ground within the right-of-way of the highway, the same shall be replaced to the satisfaction of the Engineer. Underground structures damaged by boring shall be repaired or replaced.
- 6. Construction Machinery:** All construction machinery shall be equipped with pneumatic tires when any work is done on blacktop or concrete surfaced pavements.
- 7. Pavement Openings:** Structures shall be placed under pavement by boring and jacking or cutting through the pavement and using an open trench. Tunneling will not be permitted. Cuts through concrete pavement shall be at right angles to the pavement centerline and shall be made at least six (6) inches wider on each side than the width of the trench with a minimum width of thirty-six (36) inches. Removal of all concrete pavement shall be done only with concrete saw and chisels operated by hand or compressed air. Pavement crushers of any type are prohibited. Openings shall be trimmed in straight lines with right angle corners and vertical edges. When openings are three (3) feet or less from expansion or construction joints, the pavement shall be removed to the joint.
- 8. Crossing Roadbed by Boring and Jacking:** When the pipe is installed by boring and jacking, the leading edge of the pipe must precede the auger by a distance equal to one-half the diameter of the pipe. The method to be used shall be approved by the Engineer before work is started.
- 9. Width of Trenches:** Open trenches shall be not less than two (2) feet wide, plus the diameter of the pipe, at the bottom of the excavation; and the maximum width shall be the diameter of the pipe, plus three (3) feet, or as stated on the permit. The slope of the excavated trench shall not be less than one to one.
- 10. Cribbing:** Cribbing shall be used for all trenches where necessary to protect the road surface adjacent to the trench, for safety to the workmen, to safeguard other structures within the highway, and to prevent property damage.
- 11. Excavated Material:** Excavated material shall be deposited so it will not interfere with moving traffic; and precautions must be taken to prevent excavated material from spilling out onto the traveled portion of the highway by temporary wooden retaining walls or other means approved by the Engineer.
- 12. Backfill within Traveled Way:** Backfilling trenches within the traveled portion of the street or road, that is, between the shoulders or curb lines, shall be done as follows: Material shall be sand, gravel, or sandy gravel and shall be placed in successive layers not more than six(6) inches in depth, loose measure, and each layer shall be thoroughly compacted by mechanical compaction and all backfill subject to check by the Controlled Density Method showing a minimum of ninety-five percent(95%) Proctor. All material excavated from the trench, and not used in the backfill, shall be hauled away.
- 13. Backfill Outside Traveled Way:** Backfilled trenches outside the traveled portion of the highway, that is, between the shoulders or curb and right-of-way lines, shall be done as follows: Material may be sand, gravel, or the material removed from the trench, if not frozen, except across driveways where the materials shall be sand, gravel, or sandy gravel. All backfill shall be placed in successive layers not more than twelve (12) inches in depth, loose measure, and each layer shall be thoroughly compacted by mechanical compaction and all backfill subject to check by the Controlled Density Method showing a minimum of ninety percent (90%) Proctor. Topsoil and sod shall be replaced in all trenches across lawns. All material excavated from the trench, and not used in backfill, shall be hauled away.
- 14. Tree Roots:** When tree roots are removed because of trenching, the top of the trees shall be trimmed sufficiently to balance the loss of roots. This trimming shall be done by the contractor under the direction of the City at the contractor's expense. When tree roots are bored for underground utility installations, the distance shall be one (1) foot for each one (1) inch of trunk diameter.
- 15. Temporary Crossings:** When directed by the Engineer, temporary crossing shall be provided over open trenches; and temporary wearing surface shall be placed over backfilled trenches to keep traffic moving or furnish access to abutting property.
- 16. Replacing Wearing Surface:** Permanent wearing surface of bituminous material approved by the Engineer shall be placed in trenches on all blacktop surfaced roads. The thickness shall be equal to the depth of the original blacktop or three (3) inches, whichever is greater. Permanent wearing surface of seven (7) inches of road gravel approved by the Engineer shall be placed in trenches on all gravel or dirt roads. Permanent wearing surface on concrete surfaced roads shall be new concrete pavement of the same type, thickness, and quality as the original pavement. All permanent wearing surfaces shall be placed by the applicant at his own expense.
- 17. Location of Facilities:** All facilities, both below ground and above ground, shall be located as directed by the City. Pipes shall be placed to a depth that will provide not less than four (4) feet of cover between top of roadway surface and the pipe. If at any time the position of the facility interferes with improvements to the highway, it shall be the responsibility of the applicant to move the facility to a location satisfactory to the City. All such moving shall be done at the expense of the applicant.

18. Sidewalks and Driveways: New sidewalks shall be five (5) feet wide and shall be not less than four (4) inches thick and no less than six (6) through drive approach. Concrete driveway and sidewalk material and construction shall comply with the requirements of the Michigan Department of Transportation current specifications for construction (3,500 psi maximum class design strength (6 sack) – SEC. 601, MDOT STANDARD SPECIFICATIONS FOR CONSTRUCTION.) Contractor shall grade off area on a straight line between finished sidewalk, and shoulder line or curb line; and any excess dirt shall be hauled away. The Engineer will furnish lines and grades for sidewalks.

19. Moving Oversize or Overweight Objects:

A. Oversize, or overweight objects:

1. Contractor shall submit an application to the Engineer for approval forty-eight (48) hours in advance of the move.
2. All moving shall be done on pneumatic tired trucks, trailers, moving dollies, or a combination of them; and the load shall be distributed so that no axle will carry more than legal loading.
3. Motive power shall be by pneumatic tired truck or tractor and shall be of sufficient size to handle the load without slipping.
4. Moving will not be permitted on Saturdays, Sundays, Holidays, or the day before a Holiday.
5. Contractor shall furnish the necessary traffic protection in accordance with Kent County Road Commission requirements before a move is made in the road right-of-way.

B. Oversize and overweight objects:

1. Contractor shall submit an application to the Engineer for approval seven (7) days in advance of the move.
2. All moving shall be done on pneumatic tired trucks, trailers, moving dollies, or a combination of them.
3. Items 3, 4, and 5 above shall also apply.

20. Starting the Work: The Engineer shall be given forty-eight (48) hours' notice before any of the work governed by this permit is started. Street openings shall not be started on Saturdays, Sundays, Holidays, or the day before a Holiday.

21. Restoration of Highway: The contractor shall carry on his work as here-in specified; and upon completion of the work shall restore the highway to the same condition as before the work started, including sodding, seeding, and mulching.

22. Tree Planting in Road Right-of-Way: Applicant shall submit an application to the Engineer for approval of species and location of trees in the road right-of-way.

23. Copy of Permit: The Foreman in charge of this work shall have a copy of the permit and of the specifications and conditions in his possession at all times.

24. Failure to Obtain Permit: The City reserves the right to double all fees listed hereafter where a contractor performs work in the right-of-way without the proper permits.

25. Plan Approval: Allow up to two (2) weeks for water and sewer projects.

26. Fees: All fees shall be paid at the time of obtaining permit and shall be computed according to the following schedule:

A. Transportation:

Moving oversize, but not overweight objects 12 feet-6 inches wide or less.....	\$ 25.00
Moving oversize, but not overweight objects more than 12 feet-6 inches wide but less than sixteen(16) feet wide	\$ 30.00
Moving oversize, but not overweight objects sixteen(16) feet wide or wider (plus time and material)	\$ 35.00
Moving oversize and overweight objects 12 feet-6 inches wide or less	\$ 30.00
Moving oversize and overweight objects more than 12 feet-6 inches wide but less than sixteen(16) feet wide	\$ 40.00
Moving oversize and overweight objects sixteen(16) feet wide or wider (plus time and material)	\$ 40.00
Extended transportation	\$ 100.00
Annual mobile home(14 feet wide) - up to two approved routes.....	\$ 100.00
Annual mobile home(16 feet wide) - one approved route only.....	\$100.00
House / Structure move (plus time and material).....	\$100.00

B. Establishing Grades:

Landscaping – Cut of fill (day light).....	\$ 175.00
Sidewalks, minimum charge for 100 lineal feet or less	\$ 200.00
Sidewalks, each additional 50 lineal feet.....	\$ 50.00

C. Driveways:

Residential driveway.....	\$ 130.00
Residential driveway and sidewalk up to 100 lineal feet.....	\$ 200.00
Residential driveway/sidewalk for each additional 50 lineal feet.....	\$ 50.00
Residential driveway/sidewalk restakings.....	\$ 175.00
Commercial driveway w/o curb and gutter	\$ 130.00
Commercial driveway with curb and gutter	\$ 225.00
Commercial driveway, each additional driveway.....	\$ 125.00

D. Underground:

Open cuts -	Base fee of \$300.00 with a \$500.00 Escrow... \$ 800.00
One lane	Time and Materials
Multiple Lanes	Time and materials
Utilities not crossing road.....	\$ 50.00
Utilities crossing road by boring and jacking	\$ 100.00
Utility Boring.....	\$50.00 plus \$.40/ft

E. Soil Borings:

Per job minimum	\$ 50.00
Over 25 bores	\$ 100.00

F. Miscellaneous:

All permits not listed above	\$ 50.00
------------------------------------	----------

**CITY OF KENTWOOD
BOND FOR HIGHWAY PERMITS**

KNOW ALL MEN BY THESE PRESENTS,

That _____ as Principal, and _____ as surety, of the County of _____ and State of _____ are held and firmly bound unto the City of Kentwood in the penal sum of TEN THOUSAND (\$10,000.00) Dollars, lawful money of the United States of America, for the payment of which, well and truly to be made to the said City of Kentwood, we bind ourselves, our heirs, executors and administrators, jointly and severably, firmly by these presents.

Sealed with our seal and dated this ____ day of _____, 20 ____

WHEREAS, the above bounden _____ may be granted permits for construction operations within the limits of highway right-of-way, and/or for the moving on any street or highway of any object which exceed the legal limits for either length, width, height or weight, by the City of Kentwood during the year ending December 31, 20 ____

Location of work to be done: City of Kentwood, Kent County, Michigan.

NOW, THEREFORE, The condition of the above obligation is such that if the above bounden Principal shall do all work done and performed under said permits in a careful, secure, skillful and workmanlike manner, and shall so guard the work authorized by said permits, and the materials for use during the progress thereof, that no injury, loss or damage shall occur to persons or property, and shall promptly at the conclusion of such work replace and restore the street or highway and right-of-way to as good a state and condition as the same was previous to and at the time of the opening of the same, and shall so replace and restore such street or highway and right-of-ways as to cause it to be in a state of reasonable repair so as to be reasonably safe and convenient for public travel, and to the satisfaction of the City of Kentwood, and shall save the City of Kentwood, it's employees and elected officials harmless from all claims, suits, actions, damages, or judgments against it which shall arise out of failure on the part of the above bounden Principal to comply with the terms of this bond, and if the said above bounden Principal shall also observe the statutes of the State of Michigan, and the ordinances of the County of Kent, relating to safety of highways and the requirements of the City of Kentwood Ordinances, and shall comply with all articles set forth in the "Specifications and Conditions" for highway permits and shall pay all bills rendered by the said City of Kentwood for the repair or replacement of pavement, roadway and right-of-way where disturbed or displaced by this work, then this obligation shall be null and void, otherwise to be and remain in full force and effect

Principal _____
(signature required) _____ Address _____

Print Name _____

Surety _____
(seal) _____ Address _____

POWER OF ATTORNEY must be attached to be valid