



## **Residential Driveway Installation Requirements**

### **Table of Contents**

- Residential Driveway Requirements
- Sidewalk Construction Specifications for Residential Properties
- Hold Harmless Agreement for Residential Driveways
- City Code of Ordinances for Construction of Curbs, Sidewalks and Residential Driveways
- City Code of Ordinances for Design Standards and Exceptions for Residential Driveways
- Standard Residential Driveway Schematic (where sidewalk exists)
- Standard Residential Driveway Schematic (where no sidewalk exists)

**Construction Services  
921 N Oak St  
Myrtle Beach, SC 29577  
Ph: 843-918-1111  
Fax: 843-918-1158**



**City of Myrtle Beach**  
**Department of Public Works – Engineering Division**  
**Driveway Requirements**

- A Hold Harmless Agreement is required prior to the City permitting the construction, installation and/or modification of any driveway constructed of any material other than standard concrete or asphalt, such as concrete toppings, coatings, coloring, texturing, stamping, brick pavers, turf stone and/or other similar types of materials located within the public right-of-way (see attached Hold Harmless Agreement).
- All standard concrete driveways must be constructed of 6” minimum thick 3,000 psi concrete within the public right-of-way with optional fiber mesh reinforcement only and an expansion joint provided at the property line. A minimum five feet return radii shall be provided at the juncture with the roadway. Control joints shall be installed at the five feet-return radii. Pavers installed in the public right-of-way must be set on a 6” minimum non-reinforced concrete pad.
- Any person constructing, installing and/or modifying a driveway on a state owned right-of-way must obtain a SCDOT encroachment permit, as well as a City permit, prior to the construction of the driveway.
- Existing sidewalks and/or curbing in the public right-of-way located where a driveway is to be constructed, installed and/or modified must not be disturbed, removed and/or modified in any manner except for removing the section of sidewalk where the driveway is to be installed and replacing this portion of the sidewalk with 6” minimum thickness of 3000 PSI standard concrete (see attached sidewalk specifications).
- Sidewalks, handicap ramps, curbing etc shall comply with all current requirements of the Americans with Disabilities Act (ADA).
- The Owner/Contractor must call the City of Myrtle Beach Construction Services Department at 843-918-1111 for a driveway or sidewalk form inspection prior to installing the concrete. Any issues and/or concerns can be discussed at that time. A final inspection must be called in as well for the driveway or sidewalk at completion.

*I have read and understand all of the above requirements:*

---

Property Owner/Authorized Representative (signature)

---

Print Name

---

Date



## **Sidewalk Construction Specifications**

- Sidewalks within public right-of-ways shall be 5 feet minimum in width or match existing width, with a thickness of 6”.
- Sidewalks must be 3,000 PSI concrete
- Pour on clean, dry compacted subsurface
- Contraction joints @ 5' OC
- Expansions joints at 35' Maximum OC
- No cold joints except at expansion joints
- Use fiber mesh as an additive. No steel or welded wire fabric reinforcing
- Americans with Disabilities Act (ADA) approved truncated domes shall be installed at approaching street crossings. The detectable warning tiles must be dark gray in color (Federal #36118). (Please refer to SCDOT standard drawing details for the installation of detectable warning tiles)
- Detectable warning tile installation on new sidewalks shall be cast in place (wet-set)
- Sidewalks must comply with all current regulations for the Americans with Disabilities Act (ADA). (i.e.: 2% max. cross slope and 8.33 % max. longitudinal slope.).



**City of Myrtle Beach**  
*Department of Public Works - Engineering Division*  
P.O. Drawer 2468 • Myrtle Beach, SC 29578

**HOLD HARMLESS AGREEMENT FOR  
RESIDENTIAL DRIVEWAYS**

In consideration for the City of Myrtle Beach allowing the installation of a private driveway constructed of materials not standard to the City's Operation and Maintenance Personnel, specifically, concrete toppings, coatings, coloring, texturing, stamping, brick pavers, turf stone and/or other similar types of materials located within an existing public right-of-way at Property located at \_\_\_\_\_, being Horry County TMS/PIN# \_\_\_\_\_, I/We including successors and/or assigns, agree to hold the City of Myrtle Beach or its authorized agents harmless from any claims for damages of any kind to any real and/or personal property that is located with the public right-of-way in the course of repair, maintenance and/or inspection of utilities within the right-of-way in the course of repair, maintenance and/or inspections of utilities within the right-of-way and/or any improvements of any kind by the City or its authorized agents with the public right-of-way.

The replacement and /or repair for any driveway material other than standard non-reinforced concrete shall be the responsibility of the owner, its successors and/or assigns. This agreement is not, however, intended to relieve the City or its authorized agents from liability which may arise because of its negligence or negligence of its employees.

- If a sidewalk exists, specialty material shall only be allowed to be installed between the sidewalk and the property / right-of-way line.
- If no sidewalk exists, specialty material may be installed from the property / right-of-way line up to the existing asphalt roadway. If a new sidewalk is installed where the City has previously approved a specialty material driveway, a portion of the driveway shall be removed and replaced with standard concrete to accommodate the sidewalk.

\_\_\_\_\_  
*Property Owner (sign here)*

\_\_\_\_\_  
*(please print name here)*

\_\_\_\_\_  
*Date*



## City Code of Ordinances

### ARTICLE II. CONSTRUCTION OF CURBS, SIDEWALKS AND DRIVEWAYS

#### Sec. 19-21. Permit required--Generally.

It shall be unlawful for any person to construct or reconstruct any concrete or other permanent sidewalks, curbs, or driveway entrances in or on the streets or public ways or property of the city without first obtaining a permit to do so from the city.(Code 1980, § 3-1-21)

#### Sec. 19-22. Same--For cutting or removing.

It shall be unlawful for any person to cut away or remove any curb, sidewalk or driveway entrance or any part thereof in the city unless and until a permit therefore shall have been granted by the city.(Code 1980, § 3-1-23)

#### Sec. 19-23. Plans and specifications.

No person shall construct or reconstruct any sidewalk, curb or driveway within the city except in accordance with plans and specifications approved by the director of public works, or his designee. Furthermore, the following minimum standards shall apply for driveway construction:

- (1) Driveways shall be of an approved impervious material.
- (2) The impervious surface of a driveway must extend onto the privately owned property far enough to allow parking for a vehicle to be totally on private property.
- (3) An expansion joint shall be provided at the property line.
- (4) No metal reinforcing material shall be permitted within the right-of-way.
- (5) Construction tie-in at the roadway shall not alter storm water flow.
- (6) A minimum five feet return radii shall be provided at the juncture with the roadway.(Code 1980, § 3-1-22; Ord. No. 981215-55, 12-15-98)

#### Sec. 19-24. Maintenance of barricades and warning signals near openings.

Any person cutting or removing any sidewalk, curb, or driveway entrance in the city shall protect the openings by means of proper barricades and lights and maintain such barricades during the period of the construction work.(Code 1980, § 3-1-24)



## City of Myrtle Beach Zoning Code of Ordinances

### 1702.B. Lots.

1. *Lot Size and Configuration.* If an existing building is expanded or enlarged, and additional side yard setbacks are required as a result, said additional setback requirements may be aggregated on either side of the building, provided that existing conditions would otherwise prohibit development. Further provided, that in no case shall either side yard be less than the minimum established for the zoning district in which the proposed use is located.

2. *Access.* To promote safe, convenient, and sufficient access to all properties by vehicles, pedestrians, and bicyclists, the following standards shall apply to all uses, unless otherwise noted:

- a. Every building hereafter erected or moved shall be on a lot adjacent to a public street or with deeded access to an approved and platted private street, and all structures shall be so located as to provide safe and convenient access for servicing, fire protection, and required off-street parking.
- b. All vehicular access to a development containing multiple destinations (e.g. malls, strip centers, multiple building developments, etc.) shall be provided by means of a shared driveway, side street, or frontage road.
- c. No new driveway on any development site, which accesses a public right-of-way with a posted speed limit in excess of 30 mph and an average daily traffic volume greater than five thousand vehicles per day, shall be created less than 80' from an existing driveway or street intersection except where such prohibition would deny access to the property or where compliance with sight triangle regulations cannot be met.
- d. *Intersection setback.* Driveways shall not intersect a railroad, street or alley corner radius, nor be located nearer than 20 feet from the property line at the intersection of the rights-of-way.
- e. No driveway shall be nearer than 5' from any property line, except the one it transverses, nor nearer than 20' from any other driveway, except where such prohibition would deny access to the property, where a safe sight distance cannot be achieved otherwise, or where an approved shared driveway has been or is being established.
- f. *Number of Road Access Points:*
  - i. *For all districts except Single-family Residential (R) districts.* Road access points, including dedicated public walkways and alleys, shall be allowed on the basis of two per lot and one additional access for each 100 feet of frontage in excess of 150 feet.
  - ii. *For Single-family Residential (R) districts.* Road access points, including dedicated public walkways and alleys, shall be allowed on the basis of two per lot and one additional access for each additional frontage.
- g. Driveways serving residential areas shall not exceed 20' in width at their intersection with the property boundary along any frontage. Driveways serving non-residential uses shall not exceed 30' in width at their intersection with the property boundary along any frontage except:
  - i. 40' in the Airport (AP), Light Manufacturing (LM) and Wholesale/Manufacturing (WM) districts when approved by the city engineer.
  - ii. 40' in the case of a facility dispensing motor fuel.
  - iii. 40' in the case of a one driveway at a fire station. Any additional driveway(s) may not exceed 30 feet in width.
- h. Driveways that extend into a public right-of-way shall meet the regulations of section 19-23 of the Code of Ordinances – Plans And Specifications and may require an Encroachment Permit.



CITY OF MYRTLE BEACH  
ENGINEERING - PUBLIC WORKS

STANDARD RESIDENTIAL DRIVEWAY  
(WHERE NO SIDEWALK EXISTS)

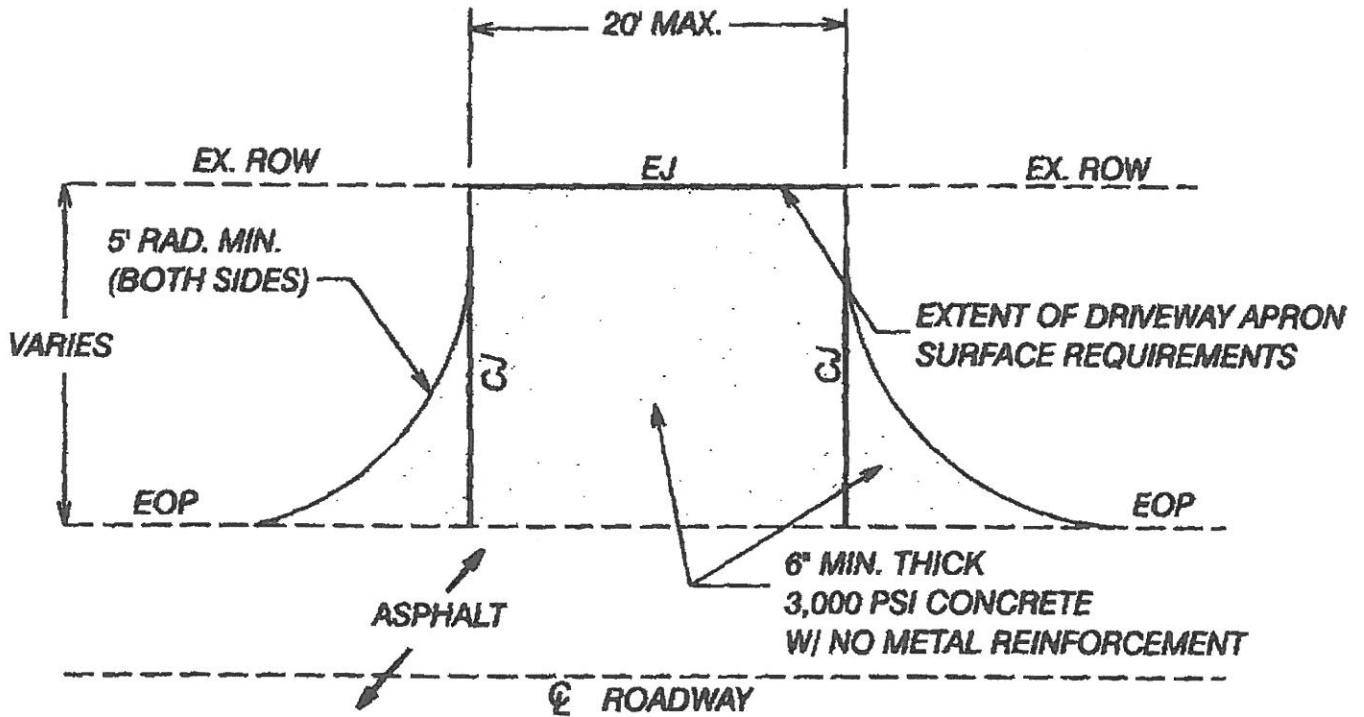

EJ = EXPANSION JOINT  
CJ = CONTROL JOINT  
EOP = EDGE OF PAVEMENT

PLAN VIEW  
NTS

\*15" MIN. RCP SHALL BE REQUIRED WHERE DITCH / SWALE EXISTS.  
ELEVATIONS MUST BE SUBMITTED TO ENSURE POSITIVE DRAINAGE  
WHEN RCP IS REQUIRED.

SEE CMB DRIVEWAY HANDOUT FOR ADDITIONAL INFORMATION.



Date: October 31, 2008