



City of San Juan Bautista Wastewater Master Plan



CITY OF SAN JUAN BAUTISTA

2020

WASTEWATER MASTER PLAN

Final

November 2020

AKEL
ENGINEERING GROUP, INC.

November 5, 2020

City of San Juan Bautista
311 2nd St
San Juan Bautista, CA 95045

Attention: Don Reynolds
City Manager

Subject: 2020 Wastewater Master Plan – Final Report

Dear Don:

We are pleased to submit the Final Report for the City of San Juan Bautista Wastewater Master Plan. This master plan is a standalone document, though it was prepared as part of the integrated infrastructure master plans for the water and wastewater master plans. The master plan documents the following:

- Existing collection system facilities, acceptable hydraulic performance criteria, and projected wastewater flows consistent with the Urban Planning Area
- Development and validation of the City's GIS-based hydraulic wastewater collection system model.
- Capacity evaluation of the existing wastewater system with improvements to mitigate existing deficiencies and to accommodate future growth.
- Capital improvement program (CIP) with an opinion of probable construction costs and suggestions for cost allocations to meet AB 1600.

We extend our thanks to you, Don Reynolds, City Manager, and other City staff whose courtesy and cooperation were valuable components in completing this study.

Sincerely,

AKEL ENGINEERING GROUP, INC.

Tony Akel, P.E.
Principal

Enclosure: Report



Acknowledgements

City Council

Mary Vasquez Edge, Mayor

Leslie Q. Jordan, Vice Mayor

Dan DeVries, Council Member

César E. Flores, Council Member

John Freeman, Council Member

Management Personnel

Don Reynolds, City Manager

Karl Bjarke, Project Manager

Julie Behzad, Contract City Engineer - CSG Consultants

Nicholas Bryan, Public Works Supervisor

Miles Farmer, WWTP Contract Operator - Cypress Water Services

Danny Gonzales, Water Systems Contract Operator - All Clear Water Services

Other City Engineering, Planning, and Operations Staff

City of San Juan Bautista Wastewater Master Plan

TABLE OF CONTENTS

PAGE NO.

ES.0 EXECUTIVE SUMMARY	ES-1
ES.1 STUDY OBJECTIVES	ES-2
ES.2 STUDY AREA	ES-2
ES.3 SYSTEM PERFORMANCE AND DESIGN CRITERIA	ES-2
ES.4 EXISTING WASTEWATER COLLECTION SYSTEM OVERVIEW	ES-2
ES.5 EXISTING AND FUTURE WASTEWATER FLOWS	ES-5
ES.6 REGIONAL TREATMENT ALTERNATIVES	ES-5
ES.7 HYDRAULIC MODEL DEVELOPMENT	ES-5
ES.8 EXISTING SYSTEM EVALUATION	ES-5
ES.9 CAPITAL IMPROVEMENT PROGRAM	ES-7
1.0 CHAPTER 1 - INTRODUCTION	1-1
1.1 BACKGROUND	1-1
1.2 SCOPE OF WORK	1-1
1.3 INTEGRATED APPROACH TO MASTER PLANNING	1-3
1.4 RELEVANT REPORTS	1-3
1.5 REPORT ORGANIZATION	1-4
1.6 ACKNOWLEDGEMENTS	1-4
1.7 UNIT CONVERSIONS AND ABBREVIATIONS	1-5
1.8 GEOGRAPHIC INFORMATION SYSTEMS	1-5
2.0 CHAPTER 2 – PLANNING AREA CHARACTERISTICS	2-1
2.1 STUDY AREA DESCRIPTION	2-1
2.2 WASTEWATER COLLECTION SYSTEM SERVICE AREA AND LAND USE	2-1
2.3 HISTORICAL POPULATION AND FUTURE GROWTH	2-5
3.0 CHAPTER 3 – SYSTEM PERFORMANCE AND DESIGN CRITERIA	3-1
3.1 HYDRAULIC CAPACITY CRITERIA	3-1
3.1.1 Gravity Mains	3-1
3.1.2 Force Mains and Lift Stations	3-5
3.2 DRY WEATHER FLOW CRITERIA	3-5
3.2.1 Unit Flow Factors Methodology	3-5
3.2.2 Average Daily Wastewater Unit Flow Factors	3-6
3.2.3 Peaking Factors	3-6
3.3 WET WEATHER FLOW CRITERIA	3-6
3.3.1 Infiltration and Inflow	3-9
3.3.2 Wastewater Collection System Flow Monitoring	3-9
3.3.3 10-Year 24-Hour Design Storm	3-9
4.0 CHAPTER 4 – EXISTING WASTEWATER COLLECTION FACILITIES	4-1
4.1 WASTEWATER COLLECTION SYSTEM OVERVIEW	4-1
4.2 WASTEWATER COLLECTION TRUNKLINE	4-1
4.3 LIFT STATIONS	4-1
4.4 WASTEWATER TREATMENT PLANT	4-4
5.0 CHAPTER 5 –WASTEWATER FLOWS	5-1
5.1 FLOWS AT THE CITY OF SAN JUAN BAUTISTA WWTP	5-1
5.2 EXISTING WASTEWATER FLOWS	5-3
5.3 BUILDOUT WASTEWATER FLOWS	5-3

City of San Juan Bautista Wastewater Master Plan

TABLE OF CONTENTS

PAGE NO.

5.4	WASTEWATER COLLECTION SYSTEM DESIGN FLOWS	5-5
6.0	CHAPTER 6 – HYDRAULIC MODEL DEVELOPMENT	6-1
6.1	OVERVIEW	6-1
6.2	HYDRAULIC MODEL SOFTWARE SELECTION	6-1
6.3	HYDRAULIC MODEL DEVELOPMENT.....	6-1
6.3.1	Skeletonization	6-2
6.3.2	Digitizing and Quality Control.....	6-2
6.3.3	Pipe and Manholes.....	6-2
6.3.4	Load Allocation	6-2
6.4	MODEL OPERATIONAL VALIDATION.....	6-3
7.0	CHAPTER 7 - EVALUATION AND PROPOSED IMPROVEMENTS.....	7-1
7.1	OVERVIEW	7-1
7.2	EXISTING COLLECTION SYSTEM CAPACITY EVALUATION.....	7-1
7.2.1	Existing Peak Dry Weather Flows Capacity Evaluation.....	7-4
7.2.2	Existing Peak Wet Weather Flows Capacity Evaluation.....	7-4
7.3	RANCHO VISTA SEWER LIFT STATION CONDITION ASSESSMENT	7-4
7.3.1	<i>Major Observations and Findings</i>	7-4
7.3.2	<i>Recommendations</i>	7-5
7.4	REGIONAL CONNECTION ALTERNATIVES.....	7-7
7.4.1	Alternative 1: On-site WWTP Upgrades and Off-Site Salinity Control	7-7
7.4.2	Alternative 2: On-site WWTP Upgrades and On-Site Salinity Control	7-9
7.4.3	Alternative 3: Regionalization with Hollister WWTP and Off-Site Salinity Control.....	7-9
7.4.4	Preferred Wastewater Treatment Improvement Alternative	7-9
7.5	ULTIMATE BUILDOUT CAPACITY IMPROVEMENTS.....	7-12
7.5.1	Recommended Pipeline Improvements	7-12
7.5.2	Recommended Lift Station Improvements	7-13
8.0	CHAPTER 8 - CAPITAL IMPROVEMENT PROGRAM.....	8-1
8.1	COST ESTIMATE ACCUARCY	8-1
8.2	COST ESTIMATE METHODOLOGY	8-2
8.2.1	Unit Costs.....	8-2
8.2.2	Construction Cost Index	8-2
8.2.3	Land Acquisition	8-2
8.2.4	Construction Contingency Allowance.....	8-2
8.2.5	Project Related Costs	8-4
8.3	CAPITAL IMPROVEMENT PROGRAM	8-4
8.3.1	Capital Improvement Costs.....	8-4
8.3.2	Regional Connection Alternatives.....	8-4
8.3.3	Recommended Cost Allocation Analysis.....	8-4
8.3.4	Construction Triggers	8-4

City of San Juan Bautista Wastewater Master Plan

TABLE OF CONTENTS

PAGE NO.

FIGURES

Figure ES.1 – Planning Boundaries	ES-3
Figure ES.2 – Existing System	ES-4
Figure ES.3 – Capital Improvement Program	ES-8
Figure 1.1 – Regional Location Map	1-2
Figure 2.1 – Planning Boundaries.....	2-2
Figure 2.2 – Existing Land Use.....	2-3
Figure 2.3 – General Plan Land Use.....	2-6
Figure 3.1 – Infiltration and Inflow Sources	3-10
Figure 4.1 – Existing System	4-2
Figure 6.1 – System Diurnals.....	6-4
Figure 7.1 – Existing System Analysis for PDWF.....	7-2
Figure 7.2 – Existing System Analysis for PWWF.....	7-3
Figure 7.3 – Regional Connection Alternatives	7-8
Figure 7.4 – Recommended Improvements	7-10
Figure 8.1 – Capital Improvement Program	8-5

City of San Juan Bautista Wastewater Master Plan

TABLE OF CONTENTS

PAGE NO.

TABLES

Table ES.1 – Wastewater Flow Unit Factor Analysis	ES-6
Table ES.2 – Buildout Capital Improvement Program	ES-9
Table 1.1 – Unit Conversions.....	1-6
Table 1.2 – Abbreviations and Acronyms.....	1-7
Table 2.1 – Existing and Future Land Use	2-4
Table 2.2 – Historical and Projected Population.....	2-7
Table 3.1 – Recommended Wastewater Collection System Performance Criteria	3-4
Table 3.2 – Wastewater Flow Unit Factor Analysis	3-7
Table 3.3 – Recommended AAF Wastewater Unit Factors	3-8
Table 3.4 – Precipitation Depth Duration Frequency.....	3-12
Table 4.1 – Existing System Inventory.....	4-3
Table 5.1 – Wastewater Treatment Plant – Historical Flow Data and Peaking Factors	5-2
Table 5.2 – Future Wastewater Flows	5-4
Table 5.3 – Design Flows	5-6
Table 7.1 – Schedule of Improvements.....	7-11
Table 7.2 – Existing Lift Station and Capacity Analysis.....	7-14
Table 8.1 – Unit Costs	8-3
Table 8.2 – Buildout Capital Improvement Program.....	8-6

City of San Juan Bautista Wastewater Master Plan

TABLE OF CONTENTS

PAGE NO.

APPENDICES

- Appendix A Wastewater Treatment Improvements Plan
- Appendix B Rancho Vista Sewer Lift Station Compliance Review

EXECUTIVE SUMMARY

The purpose of this Wastewater Master Plan is to document the planned land use for the City of San Juan Bautista (City), identify existing and future flows generated within the City, and to plan wastewater infrastructure to provide adequate levels of service to the customers at the lowest lifecycle cost feasible.

This executive summary presents a brief background of the City's wastewater collection system, the planning area characteristics, the system performance and design criteria, the hydraulic model, and a capital improvement program. A hydraulic model of the City's existing wastewater collection system was created and used to evaluate the capacity adequacy of the existing collection system and to recommend improvements to mitigate existing deficiencies, as well as servicing future growth.

The highlights of this Wastewater Master Plan are listed as follows:

1. The sewer flow projections used for ultimate build-out of the City's Planning Boundary are based on land uses from the City of San Juan Bautista 2035 General Plan and other planning documents from the City, as well as review and comments from City staff. Consumption data for the various land uses were extracted from City billing information and historical wastewater treatment plant flows (WWTP) were used to project future wastewater flows.
2. The existing deficiencies and needs for future development within the City will require a large investment in new infrastructure. This study analyzes this future development and identifies the improvements needed to serve it. Residential lands are currently built to 73 percent of the proposed land use capacity, while non-residential lands are developed to 68 percent of the proposed capacity. Thus, approximately 70 percent of the overall land use plan is built out.
3. Under existing conditions, the City's WWTP has received repeated violation notices from the Regional Water Quality Control Board for high levels of contaminants in the effluent. Various solutions to mitigate these effluent quality concerns were evaluated, with the preferred option including decommissioning the City's WWTP and rerouting wastewater flows to the City of Hollister's WWTP.
4. To meet the ultimate needs of the system, several projects are recommended, including but not limited to replacing wastewater lift station pumps, improving gravity main capacities, and constructing additional pipelines to service the needs of future customers. It should be noted that some of these improvements may require property acquisition, and which has been accounted for accordingly.

ES.1 STUDY OBJECTIVES

The City recognizes the importance of planning, developing, and financing the City's wastewater collection system infrastructure. As such, the City authorized Akel Engineering Group to prepare this 2020 Wastewater Master Plan (WWMP) and a concurrent Water Master Plan in November of 2019. This master plan included the following tasks:

- Summarizing the City's existing wastewater collection system facilities
- Documenting growth planning assumptions and known future developments
- Summarizing the wastewater collection system performance and design criteria and design storm event.
- Projecting future wastewater flows
- Developing and validating a new hydraulic model using received drawings and Geographic Information Systems (GIS) data
- Evaluating the adequacy of capacity for the wastewater collection system facilities to meet existing and projected peak dry weather flows and peak wet weather flows.
- Recommending a capital improvement program (CIP) with an opinion of probable costs
- Performing a capacity allocation analysis for cost sharing purposes
- Developing a 2020 Wastewater Master Plan report

ES.2 STUDY AREA

The City of San Juan Bautista provides wastewater collection services to more than 900 residential, commercial, industrial, and institutional accounts, with a service area that encompasses 847 acres. The City's service area, approximately 11 miles south of Gilroy, is generally bound to the north by Prescott Road, to the east by Mission Vineyard Road, to the southwest by State Route 156, and to the south by Old San Juan Hollister Road ([Figure ES.1](#)).

ES.3 SYSTEM PERFORMANCE AND DESIGN CRITERIA

This report documents the City's performance and design criteria that were used for evaluating the wastewater collection system. The system performance and design criteria are used to establish guidelines for determining future wastewater deficiencies, evaluating existing sewer collection facilities, and for sizing future facilities. Chapter 3 discusses the system performance and design criteria for the domestic water system.

ES.4 EXISTING WASTEWATER COLLECTION SYSTEM OVERVIEW

The City's wastewater collection system consists of approximately 9.3 miles of gravity mains and force mains, and 5 lift stations that convey flows to the City's WWTP. The City's existing wastewater collection system is shown in [Figure ES.2](#), which displays the existing system by pipe

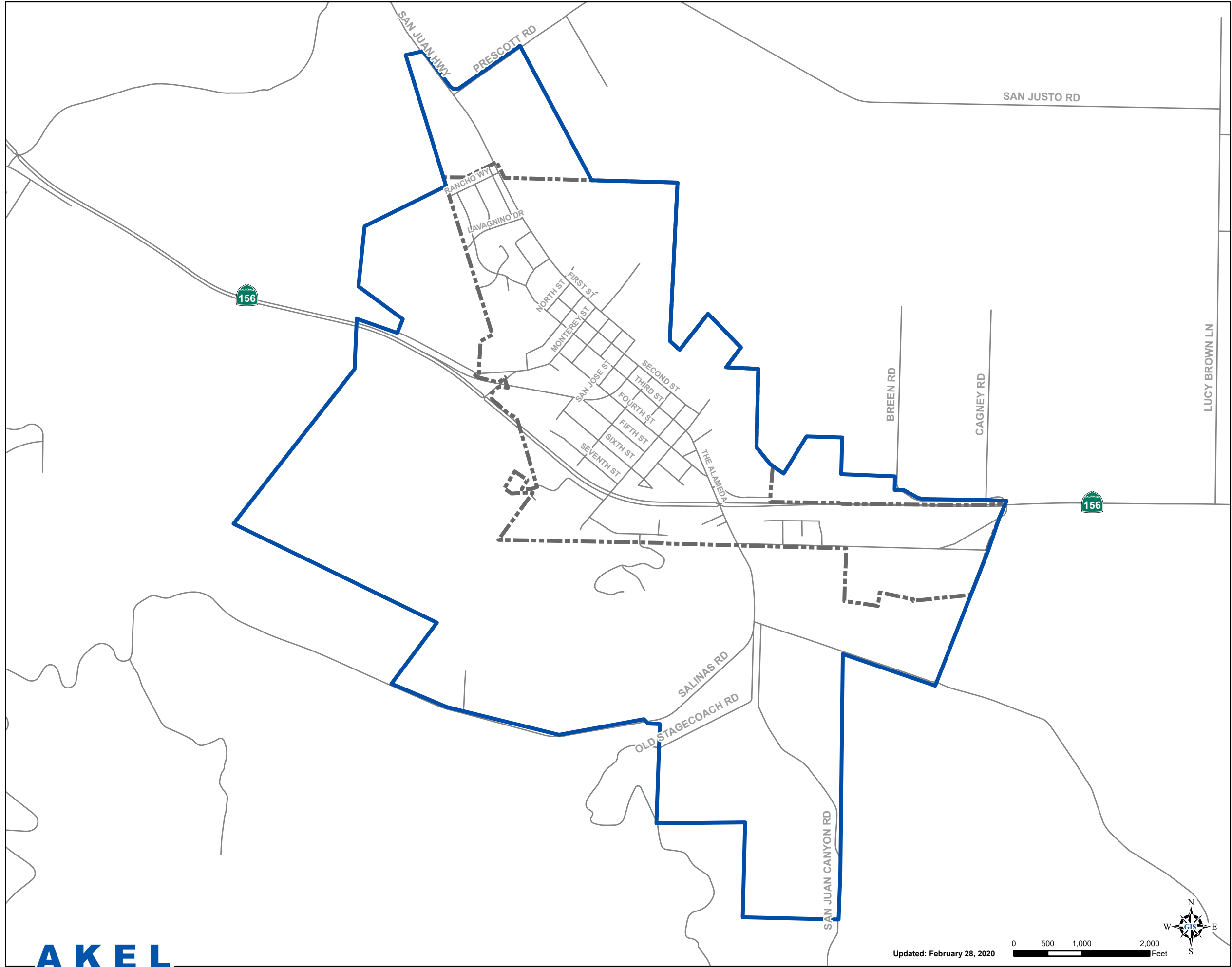

Legend



-  City Limits
-  Sphere of Influence Boundary
-  Streets



Figure ES.1
Planning Boundaries
 Wastewater Master Plan
 City of San Juan Bautista



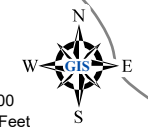
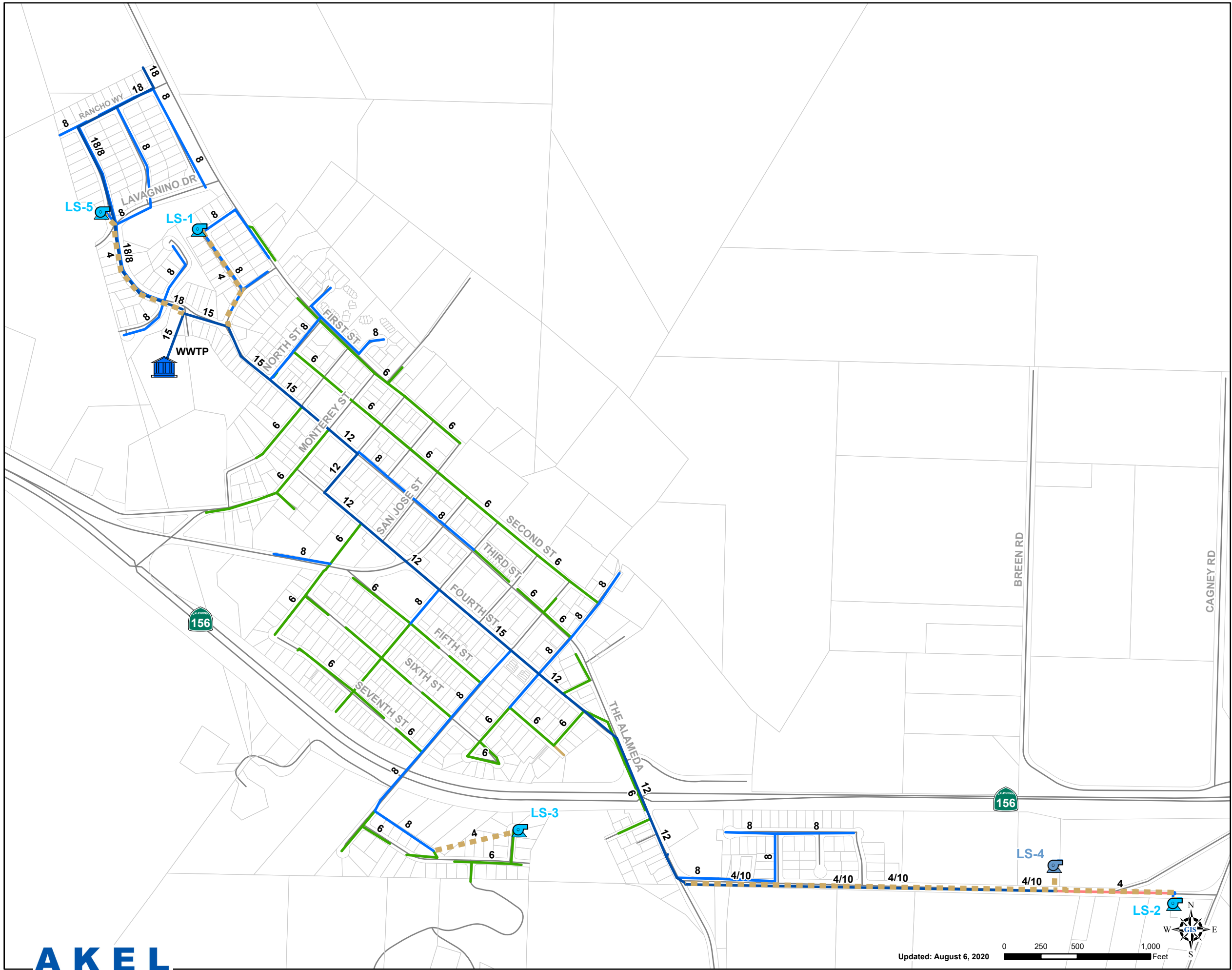

Legend

Existing System

-  WWTP
-  Lift Station
-  Private Lift Station

Gravity Mains by Diameter

-  Unknown
-  4"
-  6"
-  8"
-  10" and Greater
-  Force Mains
-  Streets
-  Parcels

Figure ES.2
Existing System
 Wastewater Master Plan
 City of San Juan Bautista



size. This figure provides a general color coding for the collection mains, as well as labeling the existing lift stations and WWTP.

ES.5 EXISTING AND FUTURE WASTEWATER FLOWS

The existing wastewater flows used for this master plan were based on the City's water billing consumption records and adjusted to match the historical WWTP inflow records and account for attenuation. The City's existing average annual WWTP flow was documented at 0.15 mgd. [Table ES.1](#) documents the future land use categories, and their corresponding wastewater flows. The average day wastewater flows from existing and future developments is estimated at 0.43 mgd. These flows were used in sizing the future infrastructure facilities, including collection mains and lift stations. Flows were also used for allocating and reserving capacities in the existing or proposed facilities.

ES.6 REGIONAL TREATMENT ALTERNATIVES

The City currently collects flows and conveys flows through the wastewater collection system to the City-owned wastewater treatment plant. This WWTP effluent has received repeated violation for salinity, sodium and total dissolved solids (TDS), and in more recent years, the Regional Water Quality Control Board has issued notices for high levels of biochemical oxygen demand (BOD), ammonia, and total suspended solids. Accordingly, and as a part of a study completed by Stantec Consulting Services, the City evaluated the existing WWTP, and options for consolidating the treatment needs with Hollister. These alternatives included on and off-site salinity control, upgrades to the WWTP, and regionalization. Ultimately, the City's "Apparent Best Project" includes regionalization with Hollister and the implementation of off-site salinity control measures with local industrial users. Part of these measures also include adapting new sources of supply from the West Hills Water Treatment Plant and mitigating impacts of self-regenerating water softeners through a buy-back program.

ES.7 HYDRAULIC MODEL DEVELOPMENT

Hydraulic network analysis has become an effective and powerful tool in many aspects of wastewater collection planning, design, operation, management, emergency response planning, and system reliability analysis. As a part of this master plan a new hydraulic model was developed for the City's wastewater collection system, combining information on the physical characteristics of the wastewater collection system (pipelines, manholes, and lift stations) and operational characteristics (how they operate). The hydraulic model development process included a thorough verification with City staff to ensure the wastewater model was consistent with the existing wastewater collection system and provided results consistent with real-world conditions.

ES.8 EXISTING SYSTEM EVALUATION

This master plan included a hydraulic evaluation of the City's existing wastewater collection system. This hydraulic evaluation included analyzing the system-wide flow levels and velocities

Table ES.1 Wastewater Flow Unit Factor Analysis

Wastewater Master Plan
City of San Juan Bautista

Land Use Classification	Existing Development within Service Area (acres)	2019 Average Daily Water Demand Unit Factors ¹		Return to Sewer Ratio	2019 Average Daily Wastewater Flow Unit Factors						
		Annual Consumption (gpd)	Unadjusted Water Unit Factor (gpd/acres)		Wastewater Flows		Wastewater Flows at 100% Occupancy		Wastewater Unit Factor		
					Unadjusted Wastewater Unit Factor (gpd/acres)	Balance to 2019 Flows (gpd)	Vacancy Rate ^{2,3} (gpd/acre)	Projected Flows at 100% Occupancy (gpd)	Recommended Factor ⁴ (gpd/acres)	Balance Using Recommended Unit Factor (gpd)	
Residential											
Low Density Residential - Rural ⁵	74	6,577	89	0.40	36	2,631	9.0%	39	2,868	40	2,955
Low Density Residential - Single Family ⁵	161	111,215	691	0.75	518	83,411	9.0%	565	90,918	570	91,788
Medium / High Density Residential	8	6,717	836	0.75	627	5,037	9.0%	683	5,491	1,125	9,043
Mission Farm RV Park ⁶	12	2,064	169	0.75	127	1,548	9.0%	138	1,688	140	1,712
<i>Subtotal Residential</i>	255	126,573				92,628			100,964		105,498
Non-Residential											
Agriculture	273	0	0	0.00	0	0	0.0%	0	0	0	0
Commercial	20	29,662	1,506	0.90	1,356	26,695	6.0%	1,437	28,297	1,440	28,358
Industrial ^{7,8}	45	17,121	382	0.00	0	0	6.0%	0	0	0	0
Mixed-Use ⁹	0	0	0	0.00	0	0	0.0%	0	0	0	0
Public Facility ¹⁰	43	3,679	85	0.75	64	2,759	0.0%	64	2,759	70	3,017
Non-Flow Generating Public Facility	15	0	0	0.00	0	0	0.0%	0	0	0	0
Earthbound Farm ¹¹	60	-	-	-	442	26,700	0.0%	442	26,700	442	26,700
True Leaf Farms ¹²	30	-	-	-	14	414	0.0%	14	414	14	414
<i>Subtotal - Non-Residential</i>	486	50,461				56,569			58,170		58,490
Other											
Open Space	5	0	0	0	0	0	0.0%	0	0	0	0
Vacant	34	0	0	0	0	0	0.0%	0	0	0	0
Other	2	0	0	0	0	0	0.0%	0	0	0	0
Williamson Act Land	65	0	0	0	0	0	0.0%	0	0	0	0
<i>Subtotal - Other</i>	106	0				0			0		0
Totals											
	848	177,034			2019 Average Annual Flows						
					Estimated Wastewater Flows	149,196			159,134		163,988
					Measured WWTP Flows ¹³	147,280					



Note:

- 2019 Water Consumption provided by City staff on January 13, 2020.
- Residential vacancy rates sourced from San Benito County 2017-2022 Comprehensive Economic Development Strategy.
- Commercial and Industrial vacancy rates sourced from San Benito County 2010 General Plan.
- Recommended Medium/High Density Residential Wastewater Flow factor based on corresponding recommended water demand factor and assumes a return-to-sewer ratio of 0.75.
- Existing acreage and consumption for low density residential land use was divided into two separate sub-types based on lot size; generally low density residential lots over 1.0 acres were considered Rural while lots under 1.0 acres were considered Single Family.
- Unit factors for Mission Farm RV Park were calculated separately from medium / high density residential land use to account for higher population density than is typical.
- Existing acreage of industrial land use and estimated wastewater flows exclude two users outside of the City's service area: Earthbound Farm & True Leaf Farms. These users operate private facilities that convey flows directly to the WWTP and have been listed separately.
- There are no known industrial users that discharge flows to the wastewater collection system, as a result the RTS for industrial users has been updated accordingly.
- Existing acreage of mixed-use land use was consolidated with its predominant land use designation.
- Existing acreage of public facility land use excludes non-demand generating parcels, such as the cemetery and wastewater treatment plant.
- Earthbound Farms wastewater discharge provided by City staff via email on June 5, 2020.
- True Leaf Farms wastewater discharge provided by City staff on June 8, 2020.
- Measured WWTP flows provided by City staff on February 18, 2020.





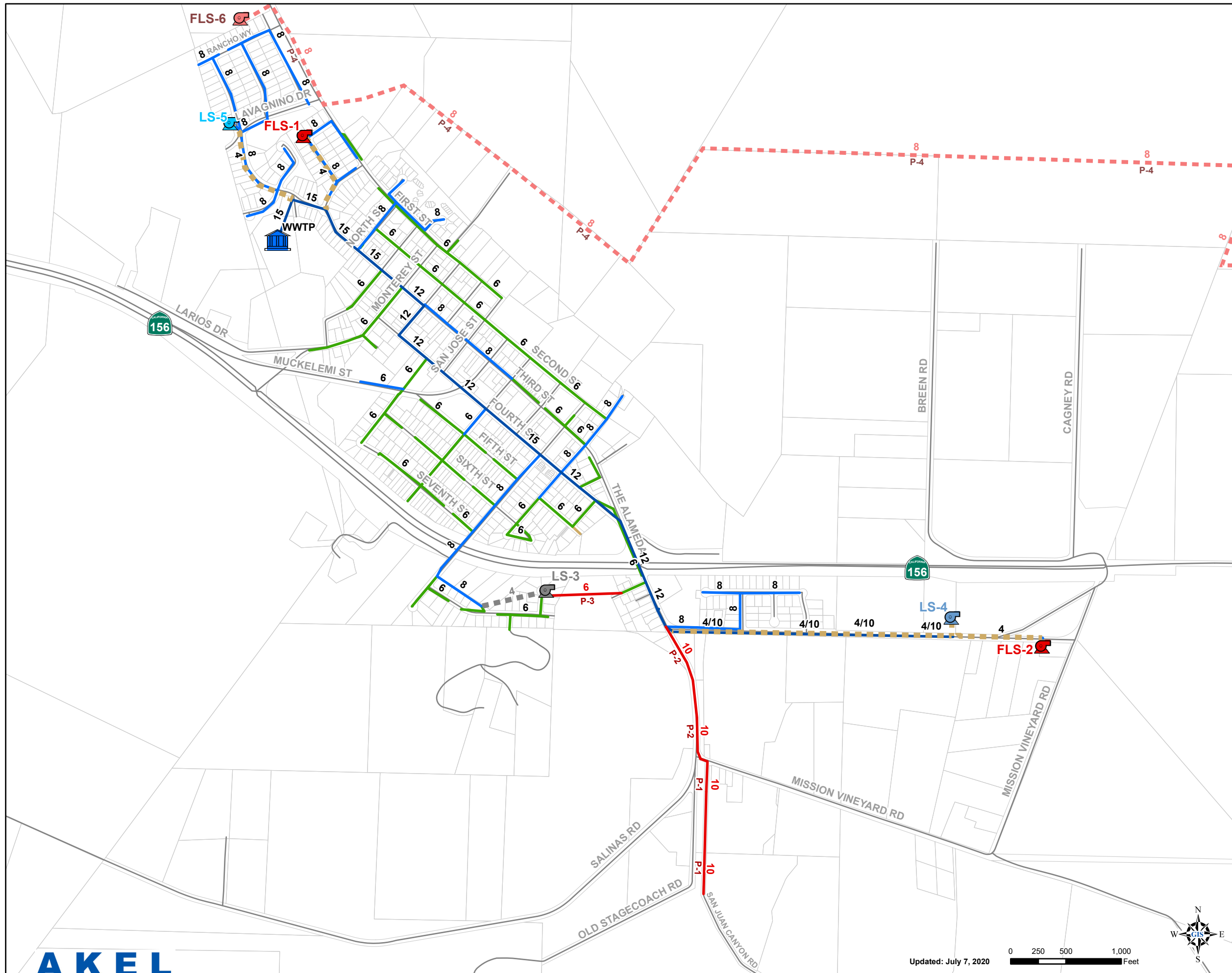

under various flow conditions comparing the pipeline capacity and lift station capacity to the required amounts based on the master plan performance criteria. The City's existing system is generally able to meet the system performance criteria under existing conditions, with exceptions noted in Chapter 7. Improvements are recommended to mitigate the deficiencies identified as part of the evaluation.

ES.9 CAPITAL IMPROVEMENT PROGRAM



The Capital Improvement Program includes improvements consistent with ongoing projects planned by the City as well as improvements recommended for mitigating existing system deficiencies and servicing future growth. **Figure ES.3** documents the recommended improvements. A detailed cost summary for the buildout improvements are documented in **Table ES.2**, as well as in Chapter 8. As shown on **Table ES.2**, the total cost over the buildout horizon is approximately 12.28 million dollars.



Legend

-  Future Lift Station
-  Hollister WWTP Connection Pump
-  Abandoned Lift Station
-  Future Pipes
-  Hollister WWTP Connection Force Main
-  Abandoned Force Main

Existing System

-  WWTP
-  Lift Station
-  Private Lift Station

Gravity Mains by Diameter

-  4"
-  6"
-  8"
-  10" and Greater
-  Force Mains
-  Streets
-  Parcels

Figure ES.3
Capital Improvement Program
 Wastewater Master Plan
 City of San Juan Bautista



Table ES.2 Buildout Capital Improvement Program
Wastewater Master Plan
City of San Juan Bautista

Improv. No.	Type of Improvement	Alignment	Limits	Improvement Details				Infrastructure Costs		Baseline Construction Cost	Estimated Construction Cost ²	Capital Improvement Cost ³	Construction Trigger	Suggested Cost Allocation		Cost Allocation	
								Unit Cost	Infr. Cost ¹					Existing Users	Future Users	Existing Users	Future Users
								(\$)	(\$)	(\$)	(\$)	(\$)	(%)	(%)	(\$)	(\$)	
Pipeline Improvements				Existing Diameter	New/ Replace	Diameter	Length										
				(in)		(in)	(ft)										
P-1	Gravity Main	San Juan Canyon Rd	From 1,200 s/o Mission Vineyard Rd to Mission Vineyard Rd	-	New	10	1,200	250	300,000	300,000	390,000	507,000	With Development	0%	100%	0	507,000
P-2	Gravity Main	Monterey and Alameda State Hwy	From Mission Vineyard Rd to Old San Juan Hollister Rd	-	New	10	1,350	250	337,500	337,500	438,800	570,500	With Development	0%	100%	0	570,500
P-3	Gravity Main	ROW	From Lang Ct. Cul-de-sac to Lang St.	-	New	6	720	168	120,960	121,000	157,300	204,500	Existing Deficiency	100%	0%	204,500	0
P-4	Force Main	Along 1st St and Future ROW north of Hwy 156	From north of Rancho Wy to Hollister WWTP	-	New	8	33,700	149	4,155,990	4,156,000	5,402,800	7,023,700	Existing Deficiency	37%	63%	2,584,021	4,439,679
P-5	Casing	ROW	Crossing under Hwy 156	-	New	28	160	709	113,514	113,600	147,700	192,100	Existing Deficiency	37%	63%	70,674	121,426
								Subtotal - Pipeline Improvements		5,027,963	5,028,100	6,536,600	8,497,800			2,859,194	5,638,606
Lift Station Improvements				Existing Capacity	New/ Replace	Capacity											
				(gpm)		(gpm)											
FLS-1	Lift Station Replacement	Lift Station 1 (SJB WWTP)		3 @ 20 gpm	Replace	3 @ 25 gpm		385,010	385,100	500,700	651,000	Existing Deficiency	97%	3%	632,397	18,603	
FLS-2	Lift Station Replacement	Lift Station 2 (Old San Juan Hollister Rd & Mission Vineyard Rd)		2 @ 100 gpm	Replace	2 @ 180 gpm		511,554	511,600	665,100	864,700	With Development	0%	100%	0	864,700	
FLS-6	New Lift Station	Approximately 200 ft n/o intersection of Rancho Wy and Vista Wy (SJB to Hollister WWTP)		-	New	4 @ 520 gpm		1,341,821	1,341,900	1,744,500	2,267,900	Existing Deficiency	37%	63%	834,361	1,433,539	
								Subtotal - Lift Station Improvements		2,238,385	2,238,600	2,910,300	3,783,600			1,466,758	2,316,842
Total Wastewater System Improvements																	
								Subtotal Pipeline Improvements		5,027,963	5,028,100	6,536,600	8,497,800			2,859,194	5,638,606
								Subtotal Lift Station improvements		2,238,385	2,238,600	2,910,300	3,783,600			1,466,758	2,316,842
								Total Improvement Costs		7,266,349	7,266,700	9,446,900	12,281,400			4,325,952	7,955,448



Notes:

1. Portions of the alignment of the pipeline P-4 exist in agricultural land with no paving, thus pipeline unit costs were reduced by 30% to account for the following: 25% reduction for pavement replacement, and 5% reduction for traffic control.
2. Baseline construction costs plus 30% to account for unforeseen events and unknown conditions.
3. Estimated construction costs plus 30% to cover other costs including: engineering design, project administration (developer and City staff), construction management and inspection, and legal costs.

CHAPTER 1 - INTRODUCTION

This chapter provides a brief background of the City of San Juan Bautista's (City) wastewater collection system, the need for this master plan, and the objectives of the study. Unit conversions, abbreviations, and definitions are also provided in this chapter.

1.1 BACKGROUND

The City of San Juan Bautista (City) is located approximately 8 miles west of Hollister, 11 miles south of Gilroy and 13 miles southeast of Watsonville ([Figure 1.1](#)). The City provides wastewater collection services to more than 900 residential, commercial, industrial, and institutional accounts. The City owns and operates a wastewater collection system that consists of approximately 9.3 miles of gravity trunks and force mains and 5 lift stations, which convey the flow to the City's Wastewater Treatment Plant (WWTP).

1.2 SCOPE OF WORK

The City authorized Akel Engineering Group to prepare this 2020 Wastewater Master Plan (WWMP) and a concurrent Water Master Plan in November of 2019. The 2020 WWMP evaluates the City's wastewater collection system and recommends capacity improvements necessary to service the needs of existing users and for servicing the future growth of the City. This 2020 WWMP is intended to serve as a tool for planning and phasing the construction of future wastewater collection system infrastructure for the projected buildout of the City's service area. The area and horizon for the master plan is based on the City's General Plan. Should planning conditions change, and depending on their magnitude, adjustments to the master plan recommendations might be necessary.

This master plan included the following tasks:

- Summarizing the City's existing wastewater collection system facilities
- Documenting growth planning assumptions and known future developments
- Summarizing the wastewater collection system performance criteria and design storm event
- Projecting future wastewater flows
- Developing and validating a new hydraulic model using received drawings and Geographic Information Systems (GIS) data
- Evaluating the adequacy of capacity for the wastewater collection system facilities to meet existing and projected peak dry weather flows and peak wet weather flows

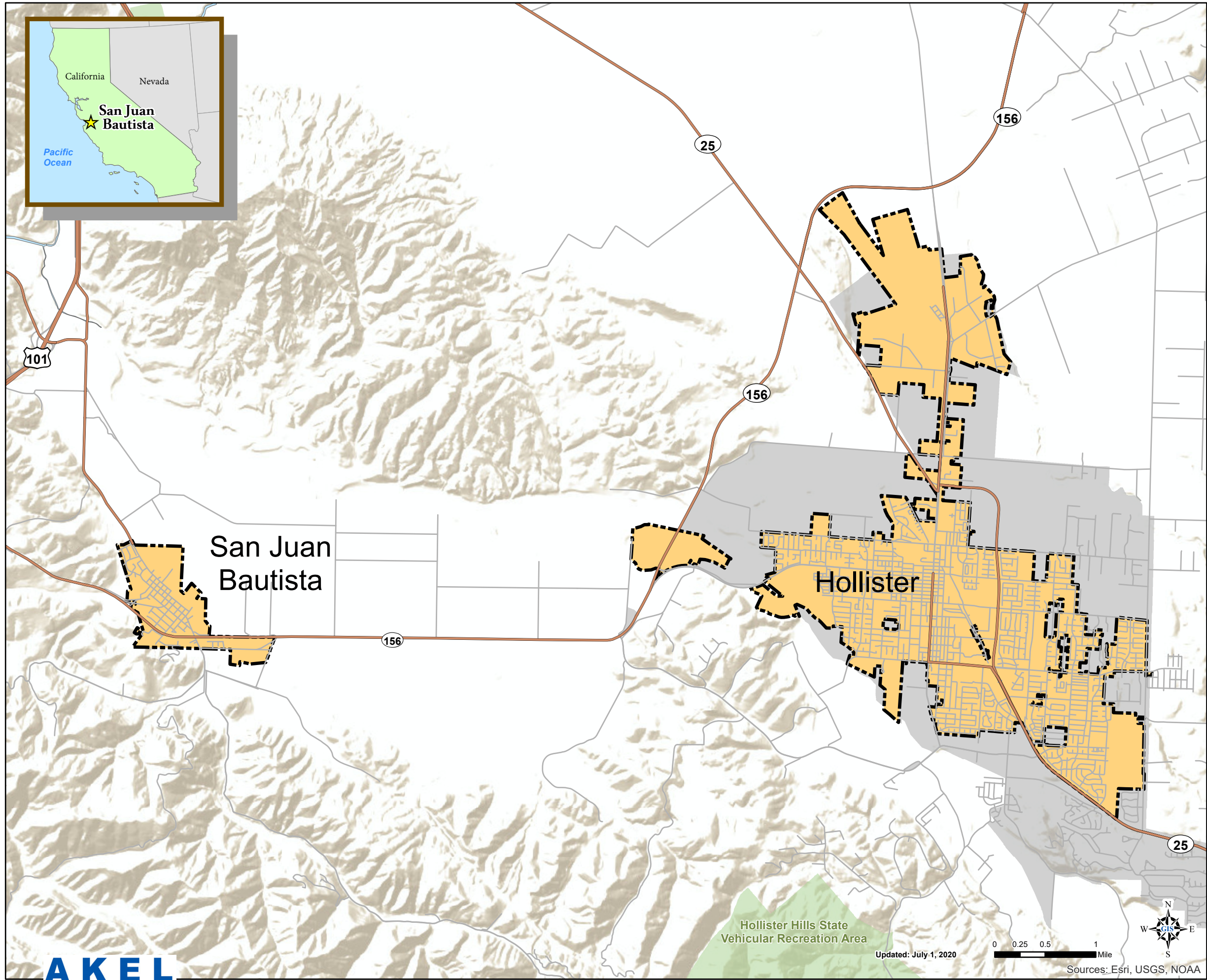

Legend







-  Major Highways
-  City Limits
-  Urbanized Area
-  Protected Open Space
-  Rivers/Streams
-  Waterbodies

Figure 1.1
Regional Location Map
 Wastewater Master Plan
 City of San Juan Bautista



- Recommending a capital improvement program (CIP) with an opinion of probable construction costs
- Performing a capacity allocation analysis for cost sharing purposes
- Developing a 2020 Wastewater Master Plan Report

1.3 INTEGRATED APPROACH TO MASTER PLANNING

The City implemented an integrated master planning approach and contracted the services of Akel Engineering Group to prepare the following documents:

- 2020 Water Master Plan
- 2020 Wastewater Master Plan

While each of these reports is published as a standalone document, they have been coordinated for consistency with the City's General Plan. Additionally, each document has been cross referenced to reflect relevant analysis results with the other documents.

1.4 RELEVANT REPORTS

The City has completed several special studies intended to evaluate localized growth. These reports were referenced and used during this capacity analysis. The following lists relevant reports that were used in the completion of this master plan, as well as a brief description of each document:

- **City of San Juan Bautista 2035 General Plan, November 2015.** The 2035 General Plan represents the official adopted goals and policies of the City of San Juan Bautista, and addresses planning issues within the community such as historic preservation, economic development, and development of public facilities. This includes establishing a plan for municipal elements such as land use, housing, and economic development.
- **City of San Juan Bautista – Wastewater Treatment Improvements Project, September 2020.** The Wastewater Treatment Improvements Project report completed by Stantec Engineering Services Inc. (Stantec) investigates alternatives to the existing WWTP and recommends a program to bring the WWTP into compliance with regulatory standards. The report is attached as [Appendix A](#).
- **City of San Juan Bautista – Rancho Vista Sewer Lift Station Compliance Review, September 2020.** The Rancho Vista Sewer Lift Station (RVSLS) Compliance Review completed by Stantec assesses the lift stations' compliance with industry standards. This includes a summary of observations and findings, and documents recommendations to bring the RVSLS up to industry standards. This report is attached as [Appendix B](#).

1.5 REPORT ORGANIZATION

The Wastewater Master Plan report contains the following chapters:

Chapter 1 – Introduction. This chapter provides a brief background of the City of San Juan Bautista’s (City) wastewater collection system, the need for this master plan, and the objectives of the study. Unit conversions, abbreviations, and definitions are also provided in this chapter.

Chapter 2 – Planning Area Characteristics. This chapter presents a discussion of the planning area characteristics and defines the land use classification.

Chapter 3 – System Performance and Design Criteria. This chapter presents the City’s performance and design criteria, which was used in this analysis for identifying current system capacity deficiencies and for sizing proposed collection mains and lift stations

Chapter 4 – Existing Wastewater Collection Facilities. This chapter provides a description of the City’s existing wastewater collection system facilities including gravity trunks, force mains, and lift stations. The chapter also includes a brief description of the City’s WWTP, which treats and disposes of the wastewater for the City.

Chapter 5 – Wastewater Flows. This chapter summarizes historical wastewater flows experienced at the City’s WWTP and defines flow terminologies relevant to this evaluation. This chapter discusses the design flows used in the hydraulic modeling effort and capacity evaluation. The design flows include the existing condition (existing customers) and buildout development conditions.

Chapter 6 – Hydraulic Model Development. This chapter describes the development and validation of the City’s wastewater collection system hydraulic model. The City’s hydraulic model was used to evaluate the capacity adequacy of the existing system and to plan its expansion to service anticipated future growth.

Chapter 7 – Evaluation and Proposed Improvements. This section presents a summary of the wastewater collection system evaluation and identifies improvements needed to mitigate existing deficiencies, as well as improvements needed to expand the system and service growth.

Chapter 8 – Capital Improvement Program. This chapter provides a summary of the recommended wastewater collection system improvements to mitigate existing capacity deficiencies and service future growth. This chapter also presents the cost criteria and methodologies for developing the capacity improvement costs. Finally, a capacity allocation analysis, usually used for cost sharing purposes, is also included.

1.6 ACKNOWLEDGEMENTS

Obtaining the necessary information to successfully complete the analysis presented in this report, and developing the long-term strategy for mitigating the existing system deficiencies and

for accommodating future growth, was accomplished with the strong commitment and very active input from dedicated team members including:

- Don Reynolds, City Manager
- Karl Bjarke, Project Manager
- Julie Behzad, Contract City Engineer – CSG Consultants
- Nicholas Bryan, Public Works Supervisor
- Miles Farmer, WWTP Contract Operator – Cypress Water Services
- Danny Gonzales, Water Systems Contract Operator – All Clear Water Services

As part of the preparation of this Wastewater Master Plan, Stantec Inc. prepared reports evaluating treatment strategies for both water supply sources and collected wastewater flows.

1.7 UNIT CONVERSIONS AND ABBREVIATIONS

Engineering units were used in reporting flow rates and volumes pertaining to the design and operation of various components of the wastewater collection system. Where it was necessary to report values in smaller or larger quantities, different sets of units were used to describe the same parameter. Values reported in one set of units can be converted to another set of units by applying a multiplication factor. A list of multiplication factors for units used in this report are shown on [Table 1.1](#).

Various abbreviations and acronyms were also used in this report to represent relevant wastewater collections system terminologies and engineering units. A list of abbreviations and acronyms is included in [Table 1.2](#).

1.8 GEOGRAPHIC INFORMATION SYSTEMS

This master planning effort made extensive use of Geographic Information Systems (GIS) technology, for completing the following tasks:

- Develop the physical characteristics of the hydraulic model (gravity mains, force mains, and lift stations).
- Allocate existing wastewater loads, as calculated using the developed wastewater unit factors.
- Calculate and allocate future wastewater loads, based on the future developments' wastewater flows
- Extract ground elevations along the gravity and force mains from available contour maps and digital elevation models.
- Generate maps and exhibits used in this master plan

Table 1.1 Unit Conversions
Wastewater Master Plan
City of San Juan Bautista

Volume Unit Calculations		
To Convert From:	To:	Multiply by:
acre feet	gallons	325,857
acre feet	cubic feet	43,560
acre feet	million gallons	0.3259
cubic feet	gallons	7.481
cubic feet	acre feet	2.296×10^{-5}
cubic feet	million gallons	7.481×10^{-6}
gallons	cubic feet	0.1337
gallons	acre feet	3.069×10^{-6}
gallons	million gallons	1×10^{-6}
million gallons	gallons	1,000,000
million gallons	cubic feet	133,672
million gallons	acre feet	3.069
Flow Rate Calculations		
To Convert From:	To:	Multiply By:
ac-ft/yr	mgd	8.93×10^{-4}
ac-ft/yr	cfs	1.381×10^{-3}
ac-ft/yr	gpm	0.621
ac-ft/yr	gpd	892.7
cfs	mgd	0.646
cfs	gpm	448.8
cfs	ac-ft/yr	724
cfs	gpd	646300
gpd	mgd	1×10^{-6}
gpd	cfs	1.547×10^{-6}
gpd	gpm	6.944×10^{-4}
gpd	ac-ft/yr	1.12×10^{-3}
gpm	mgd	1.44×10^{-3}
gpm	cfs	2.228×10^{-3}
gpm	ac-ft/yr	1.61
gpm	gpd	1,440
mgd	cfs	1.547
mgd	gpm	694.4
mgd	ac-ft/yr	1,120
mgd	gpd	1,000,000

Table 1.2 Abbreviations and Acronyms
Wastewater Master Plan
City of San Juan Bautista

Abbreviation	Expansion	Abbreviation	Expansion
2020 WWMP	2020 Wastewater Master Plan	HGL	Hydraulic Grade Line
10yr-24hr	10-Year 24-Hour	in/hr	Inch per Hour
AACE	Association for the Advancement of Cost Engineering	I&I	Infiltration and Inflow
ADWF	Average Dry Weather Flow	LF	Linear Feet
AAF	Annual Average Flow	LS	Lift Station
Akel	Akel Engineering Group, Inc.	MBR	Membrane Bioreactor
AWWF	Average Wet Weather Flow	MDDWF	Maximum Day Dry Weather Flow
CCI	Construct Cost Index	MDWWF	Maximum Day Wet Weather Flow
CIP	Capital Improvement Program	MGD	Million Gallons per Day
CIPP	Cured in Place Pipe	MMDWF	Maximum Month Dry Weather Flow
DDF	Depth Duration Frequency	MMWWF	Maximum Month Wet Weather Flow
d/D	depth of flow to pipe diameter	NASSCO	National Association of Sewer Service Companies
City/CoSB	City of San Juan Bautista	NOAA	National Oceanic and Atmospheric Administration
ENR	Engineering News Record	PDWF	Peak Dry Weather Flow
ft	Feet	PWWF	Peak Wet Weather Flow
fps	Feet per Second	RO	Reverse Osmosis
FY	Fiscal Year	ROW	Right of Way
GIS	Geographic Information Systems	SBR	Sequencing Batch Reactor
gpcd	Gallons per day per capita	UWMP	Urban Water Management Plan
gpd	Gallons per Day	WWMP	Wastewater Master Plan
gpm	Gallons per Minute	WWTP	Wastewater Treatment Plant
HE	Household equivalent		

CHAPTER 2 – PLANNING AREA CHARACTERISTICS

This chapter presents a discussion of the planning area characteristics and defines the land use classification.

2.1 STUDY AREA DESCRIPTION

The City of San Juan Bautista is located in San Benito County, approximately 11 miles south of Gilroy and 13 miles southeast of Watsonville. The City's closest neighbor, the City of Hollister, is located 8 miles to the east. State Route 156 bisects the boundary of the City in the east-west direction. The City limits currently encompass 0.79 square miles, with an approximate population of 2,100 residents.

The City's service area is generally bound to the north by Prescott Road, to the east by Mission Vineyard Road, to the southwest by State Route 156, and to the south by Old San Juan Hollister Road. The topography is generally flat, with slopes increasing from north to south toward the Gabilan Mountain Range. **Figure 2.1** displays the assumed sphere of influence boundary as documented in the General Plan. This boundary has not yet been adopted by City staff but was used for planning purposes as part of this master plan.

The City operates and maintains a wastewater collection system that covers the majority of the developable area within the Planning Boundary. Currently, the wastewater flows are conveyed to the City of San Juan Bautista Wastewater Treatment Plant (WWTP).

2.2 WASTEWATER COLLECTION SYSTEM SERVICE AREA AND LAND USE

The City's wastewater collection system services residential and non-residential lands primarily within the City limits, as summarized on **Table 2.1** and shown graphically on **Figure 2.2**. Areas within the City's potential wastewater collection service area include:

- 741 acres of flow generating lands including residential and non-residential areas.
- 106 acres of undeveloped lands inside the service area.

The existing land use statistics were based on land use information received from City staff. Plan, however for the purposes of estimating wastewater flows, these acreages were assumed to retain their existing land use, such as residential or commercial. It should be noted that two industrial users, Taylor/Earthbound Farms and True Leaf Farms, operate private water and wastewater facilities; these users are not serviced by the City's water system but do convey wastewater flows to the WWTP. For planning purposes, the acreage from these two developments are included in **Table 2.1**.

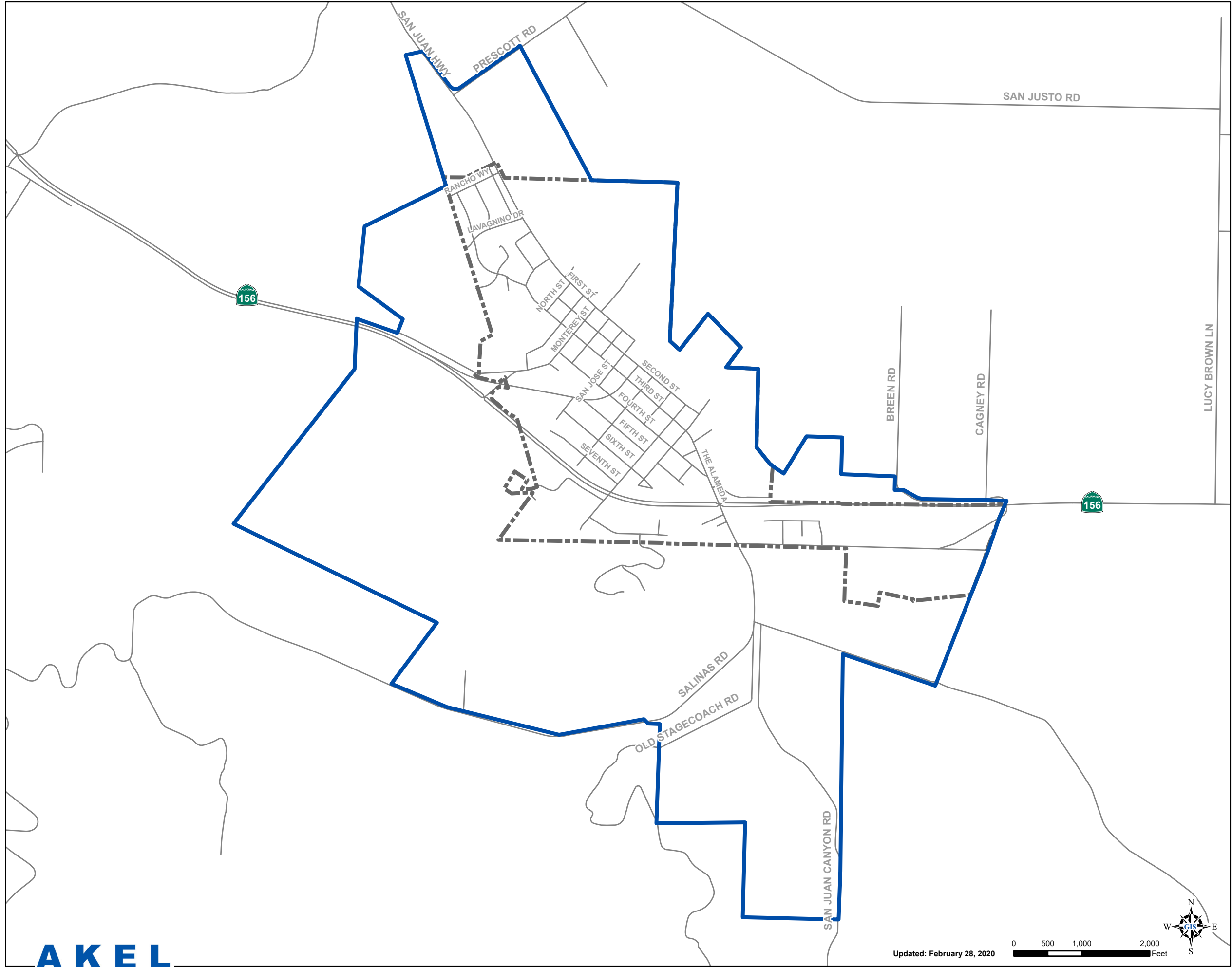

Legend



-  City Limits
-  Sphere of Influence Boundary
-  Streets

Figure 2.1
Planning Boundaries
 Wastewater Master Plan
 City of San Juan Bautista



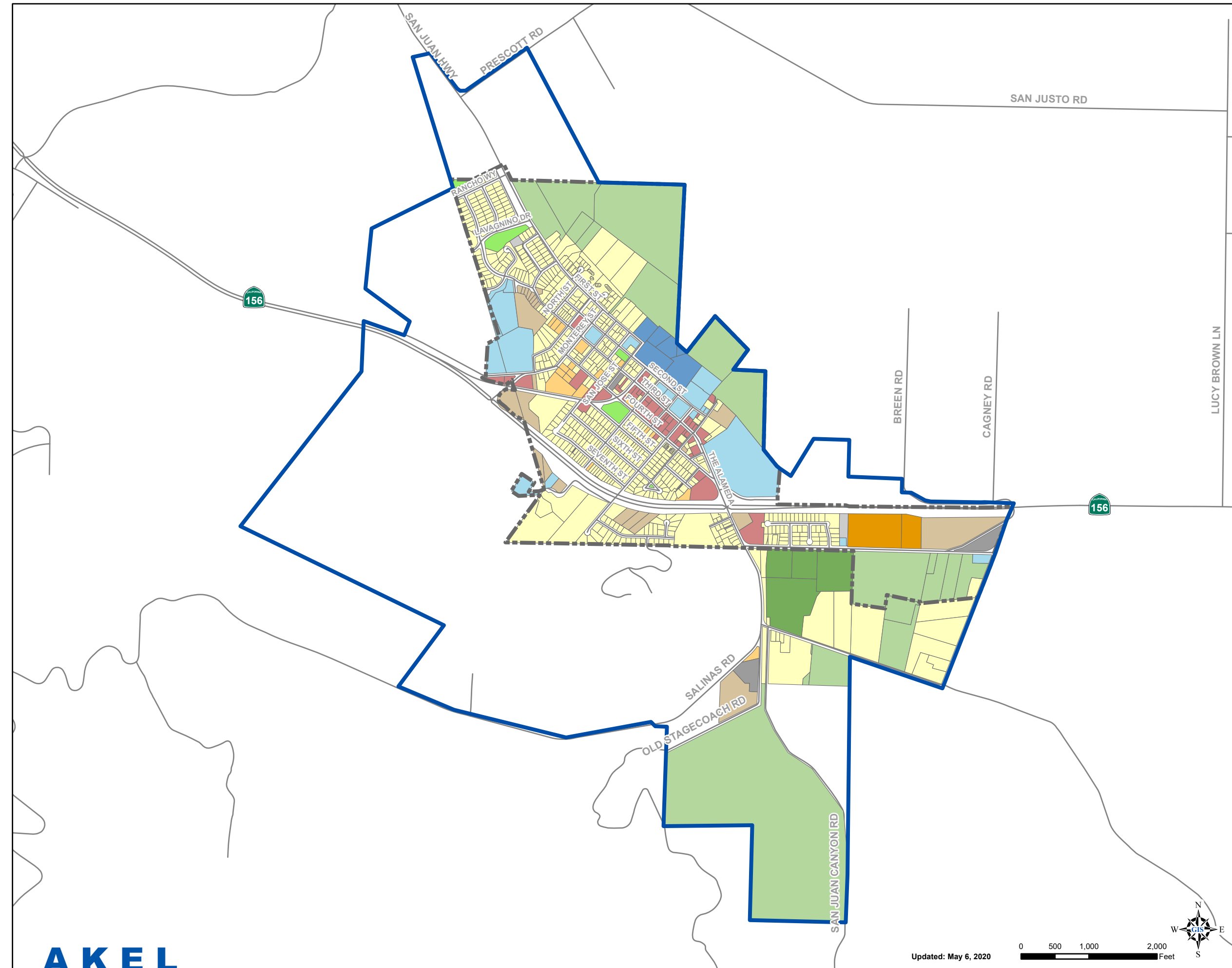

Legend

Existing Land Use

- Low Density Residential
- Medium Density Residential
- High Density Residential
- Commercial
- Public Facility
- Mission
- Industrial
- Agriculture
- Open Space
- Williamson Act Land
- Vacant
- Other
- Streets
- City Limits
- Sphere of Influence Boundary

Figure 2.2
Existing Land Use
 Wastewater Master Plan
 City of San Juan Bautista



Table 2.1 Existing and Future Land Use

Wastewater Master Plan

City of San Juan Bautista

Land Use Classification	Existing Development			Future Development				Total Development
	Existing Development	Existing Lands - Redeveloping	Subtotal Existing Development - Unchanged	New Lands - Redevelopment	New Development		New Development	
	(acres)	(acres)	(acres)	(acres)	Inside City Limits	Outside City Limits	(acres)	
Residential								
Residential	255.2	-37.8	217.4	59.0	14.8	6.0	20.9	297.2
Subtotal Residential	255.2	-37.8	217.4	59.0	14.8	6.0	20.9	297.2
Non-Residential								
Agriculture	273.2	-178.1	95.1	0.0	1.5	0.0	1.5	96.7
Commercial	19.7	-1.3	18.4	117.0	6.1	0.0	6.1	141.5
Industrial	134.7	0.0	134.7	34.7	0.0	0.0	0.0	169.4
Mixed-Use	0.0	0.0	0.0	0.0	0.0	0.0	0.0	0.0
Public Facility	58.4	-0.9	57.5	10.5	2.4	0.0	2.4	70.3
Subtotal Non-Residential	486.0	-180.3	305.7	162.2	10.0	0.0	10.0	477.9
Other								
Open Space	5.3	-3.1	2.2	0.0	3.0	0.0	3.0	5.3
Vacant	34.1	-34.1	0.0	0.0	0.0	0.0	0.0	0.0
Williamson Act Land	65.3	0.0	65.3	0.0	0.0	0.0	0.0	65.3
Other	1.6	0.0	1.6	0.0	0.0	0.0	0.0	1.6
Subtotal- Other	106.4	-37.2	69.1	0.0	3.0	0.0	3.0	72.2
Total								
Subtotal - Residential & Non-Residential	741.2	-218.2	523.1	221.2	24.8	6.0	30.9	775.1
Subtotal - Other	106.4	-37.2	69.1	0.0	3.0	0.0	3.0	72.2
Total Area	847.6	-255.4	592.2	221.2	27.9	6.0	33.9	847.3



Notes:

1. Source: GIS information downloaded from San Benito County Website (11/05/2019).

The buildout of the City’s Sphere of Influence includes approximately 300 acres of residential land use, 480 acres of non-residential land use, and 70 acres of other open space land uses as documented on [Table 2.1](#) and shown graphically on [Figure 2.3](#). The land use designation utilized in this master plan are consistent with the Land Use Element of the City’s General Plan, and as received from the City’s planning division.

2.3 HISTORICAL POPULATION AND FUTURE GROWTH

The City of San Juan Bautista is a growing community, with over 8% of the San Benito County population residing within the City’s service area limits. Records obtained from California Department of Finance estimate the 2019 population at approximately 2,081 people. From 2015 to present the City’s service area has observed an average annual growth rate of approximately 1.9 percent.

The General Plan anticipates a 2035 population of 3,500 and this 2020 WWMP is consistent with the General Plan projections. The current and projected service area population is summarized in [Table 2.2](#).

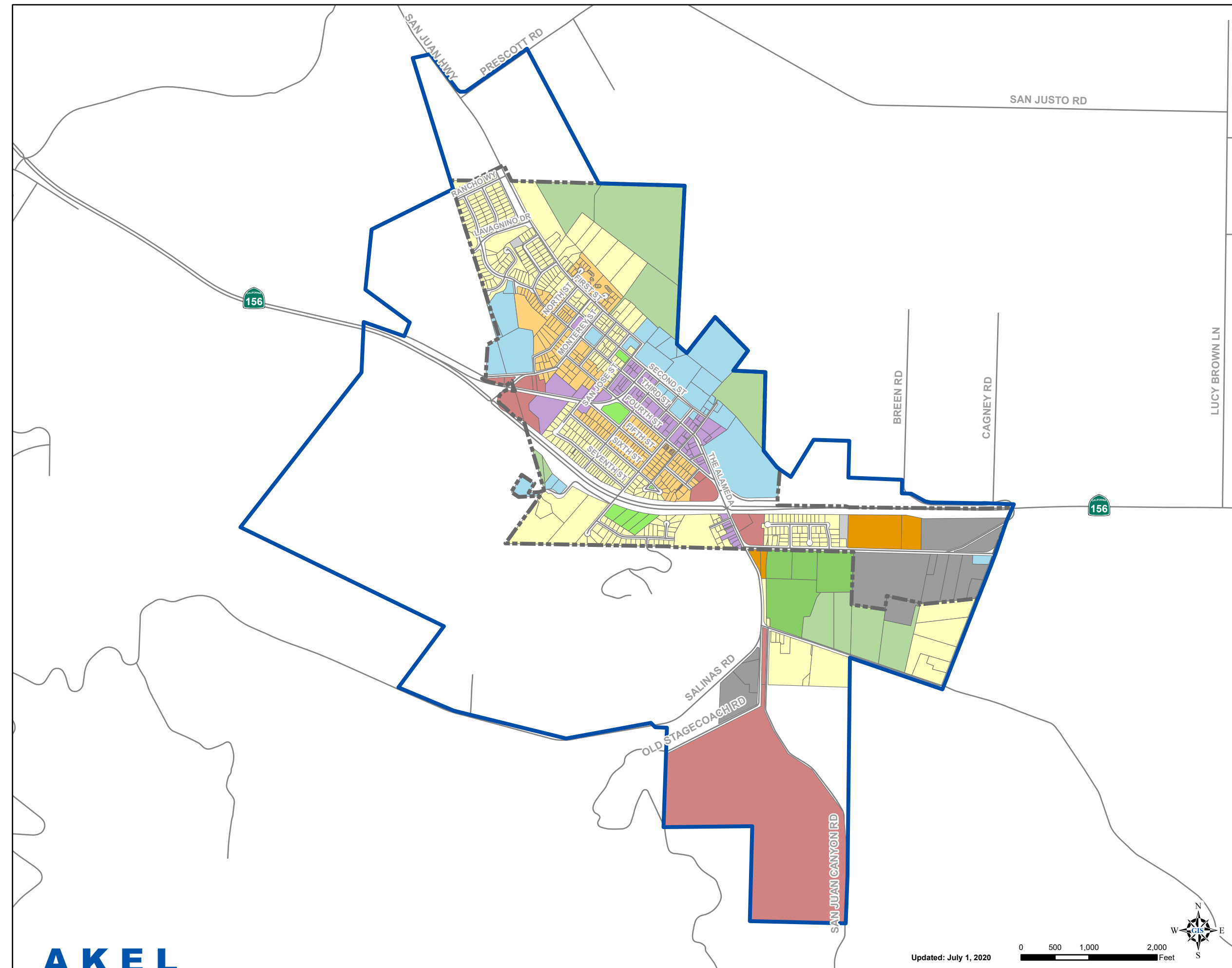

Legend

General Plan Land Use

- Low Density Residential
- Medium Density Residential
- High Density Residential
- Commercial
- Mixed Use
- Public Facility
- Industrial
- Agriculture
- Open Space
- Williamson Act Land
- Other
- Streets
- City Limits
- Sphere of Influence Boundary

Figure 2.3
General Plan Land Use
 Wastewater Master Plan
 City of San Juan Bautista



Table 2.2 Historical and Projected PopulationWastewater Master Plan
City of San Juan Bautista

Year	Population	Annual Growth(%)
Historical¹		
2000	1,549	-
2001	1,566	1.1%
2002	1,579	0.8%
2003	1,594	0.9%
2004	1,690	6.0%
2005	1,688	-0.1%
2006	1,683	-0.3%
2007	1,779	5.7%
2008	1,835	3.1%
2009	1,852	0.9%
2010	1,862	0.5%
2011	1,873	0.6%
2012	1,881	0.4%
2013	1,895	0.7%
2014	1,914	1.0%
2015	1,930	0.8%
2016	1,943	0.7%
2017	1,981	2.0%
2018	1,986	0.3%
2019	2,081	4.8%
Projected²		
2020	2,158	3.7%
2021	2,239	3.7%
2022	2,322	3.7%
2023	2,409	3.7%
2024	2,499	3.7%
2025	2,593	3.7%
2026	2,671	3.0%
2027	2,751	3.0%
2028	2,834	3.0%
2029	2,919	3.0%
2030	3,007	3.0%
2031	3,097	3.0%
2032	3,190	3.0%
2033	3,285	3.0%
2034	3,384	3.0%
2035	3,485	3.0%
2036	3,591	3.0%
2037	3,700	3.0%
2038	3,812	3.0%
2039	3,928	3.0%
2040	4,047	3.0%
2041	4,170	3.0%
2042	4,296	3.0%
2043	4,426	3.0%
2044	4,561	3.0%
2045 ³	4,699	3.0%



4/2/2020

Note :

1. Historical Populations per California Department of Finance estimates.
2. Unless noted otherwise, projected population extracted from San Juan Bautista 2035 General Plan and normalized to historical population:
Year 2021 - 2024: Exponential interpolation between 2020 and 2025.
Year 2026 - 2029: Exponential interpolation between 2025 and 2030.
Year 2031 - 2034: Exponential interpolation between 2030 and 2035.
3. 2045 population based on land use holding capacity of future residential development and maximum residential land use densities designated by the General Plan.

CHAPTER 3 – SYSTEM PERFORMANCE AND DESIGN CRITERIA

This chapter presents the City’s performance and design criteria, which was used in this analysis for identifying current system capacity deficiencies and for sizing proposed collection mains and lift stations

3.1 HYDRAULIC CAPACITY CRITERIA

In addition to applying the City design standards for evaluating hydraulic capacities this master plan included dynamic hydraulic modeling. The dynamic modeling was a critical and essential element in identifying surcharge conditions resulting from downstream bottlenecks in the gravity mains.

3.1.1 Gravity Mains

Gravity main capacities depend on several factors including: material and roughness of the pipe, the limiting velocity and slope, and the maximum allowable depth of flow. The hydraulic modeling software used for evaluating the capacity adequacy of the City’s wastewater collection system, InfoSWMM by Innovyze Inc., utilizes the fully dynamic St. Venant’s equation which has a more accurate engine for simulating backwater and surcharge, in addition to manifolded force mains. The software also incorporates the use of the Manning Equation in other calculations including upstream pipe flow conditions.

Manning’s Equation for Pipe Capacity

The Continuity equation and the Manning equation for steady-state flow are used for calculating pipe capacities in open channel flow. Open channel flow can consist of either open conduits or, in the case of gravity mains, partially full closed conduits. Gravity full flow occurs when the conduit is flowing full but has not reached a pressure condition.

- Continuity Equation: $Q = V A$

Where:

Q = peak flow, in cubic feet per second (cfs)

V = velocity, in feet per second (fps)

A = cross-sectional area of pipe, in square feet (sq. ft.)

- Manning Equation: $V = (1.486 R^{2/3} S^{1/2})/n$

Where:

V = velocity, fps

n = Manning’s roughness coefficient

R = hydraulic radius (area divided by wetted perimeter), ft

S = slope of pipe, in feet per foot

St. Venant's Equation for Pipe Capacity

Dynamic modeling facilitates the analysis of unsteady and non-uniform flows (dynamic flows) within a wastewater collection system. Some hydraulic modeling programs have the ability to analyze these types of flows using the St. Venant equation, which take into account unsteady and non-uniform conditions that occur over changes in time and cross-section within system pipes.

The St. Venant equation is a set of two equations, a continuity equation and a dynamic equation, that are used to analyze dynamic flows within a system. The first equation, the continuity equation, relates the continuity of flow mass within the system pipes in terms of: (A) the change in the cross-sectional area of flow at a point over time and (B) The change of flow over the distance of piping in the system. The continuity equation is provided as follows:

- Continuity Equation:
$$\frac{\partial A}{\partial t} + \frac{\partial Q}{\partial x} = 0$$

(A) (B)

Where:

t = time

x = distance along the longitudinal direction of the channel

Q = discharge flow

A = flow cross-sectional area perpendicular to the x directional axis

The second equation, the dynamic equation, relates changes in flow to fluid momentum in the system using: (A) Changes in acceleration at a point over time, (B) Changes in convective flow acceleration, (C) Changes in momentum due to fluid pressure at a given point, (D) Changes in momentum from the friction slope of the pipe and (E) Fluid momentum provided by gravitational forces. The dynamic equation is provided as follows:

- Dynamic Equation:
$$\frac{\partial Q}{\partial t} + \frac{\partial}{\partial t} \left(\beta \frac{Q^2}{A} \right) + gA \frac{\partial y}{\partial x} + gAS_f - gAS_o = 0$$

(A) (B) (C) (D) (E)

Where:

t = time

x = distance along the longitudinal direction of the channel

Q = discharge flow

A = flow cross-sectional area perpendicular to the x directional axis

y = flow depth measured from the channel bottom and normal to the x directional axis

S_f = friction slope

S_o = channel slope

β = momentum

g = gravitational acceleration

Use of this method of analysis provides a more accurate and precise analysis of flow conditions within the system compared to steady state flow analysis methods. It must be noted that two

assumptions are made for use of St. Venant equations in the modeling software. First, flow is one dimensional. This means it is only necessary to consider velocities in the downstream direction and not in the transverse or vertical directions. Second, the flow is gradually varied. This means the vertical pressure distribution increases linearly with depth within the pipe.

Manning's Roughness Coefficient (n)

The Manning roughness coefficient 'n' is a friction coefficient that is used in the Manning formula for flow calculation in open channel flow. In wastewater collection systems, the coefficient can vary between 0.009 and 0.017 depending on pipe material, size of pipe, depth of flow, root intrusion, smoothness of joints, and other factors.

For the purpose of this evaluation, and in accordance with City standards, an "n" value of 0.011 was used for both existing and proposed gravity pipes unless directed otherwise by City staff based on pipe structural condition. This "n" value is an acceptable practice in planning studies.

Partial Flow Criteria (d/D)

Partial flow in gravity mains is expressed as a depth of flow to pipe diameter ratio (d/D). For circular gravity conduits, the highest capacity is generally reached at 92 percent of the full height of the pipe (d/D ratio of 0.92). This is due to the additional wetted perimeter and increased friction of a gravity pipe.

When designing wastewater pipelines, it is common practice to use variable flow depth criteria that allow higher safety factors in larger sizes. Thus, design d/D ratios may range between 0.5 and 0.92, with the lower values used for smaller pipes. The smaller pipes may experience flow peaks greater than planned or may experience blockages from debris. The City's design standards pertaining to the d/D criteria are summarized on [Table 3.1](#).

During peak dry weather flows (PDWF), the maximum allowable d/D ratio for proposed pipes (all diameters) is 0.75. The maximum allowable d/D ratio for all existing pipes (all diameters) is 0.90. The criterion for existing pipes is relaxed in order to maximize the use of the existing pipes before costly pipes improvements are required.

During peak wet weather flows (PWWF), to avoid premature or unnecessary trunk line replacements, the capacity analysis allowed the d/D ratio to exceed the dry weather flow criteria and surcharge. This condition is evaluated using the dynamic hydraulic model and the criteria listed on [Table 3.1](#), which stipulates that the hydraulic grade line (HGL), even during a surcharged condition, should be at least five feet below the manhole rim elevation.

Minimum Pipe Sizes and Design Velocities

In order to minimize the settlement of sewage solids, it is standard practice in the design of gravity mains to specify that a minimum velocity of 2 feet per second (fps) be maintained when the pipeline is half-full. At this velocity, the w flow will typically result with self-cleaning of the pipe.

Table 3.1 Recommended Wastewater System Performance Criteria

Wastewater Master Plan
City of San Juan Bautista

Dry Weather Flow Criteria ¹	
Sewer Trunk	d/D
Existing System	0.90
Future System	0.75
Wet Weather Flow Criteria ¹	
HGL must be at least 5 feet below manhole rim elevation	
Pipe Slope Criteria ¹	
Pipe Size	Minimum Slope (ft/ft)
8"	0.0035
10"	0.0025
12"	0.0020
15"	0.0015
18"	0.0012
21"	0.0010
24" to 60"	0.0008
Manning's Roughness Coefficient ²	
Gravity Sewer (PVC, ABS, & HDPE)	n = 0.011
Force Main	c = 130
Pipe Velocity Criteria	
Pipe Type	Minimum Velocity (fps)
Gravity Sewer	Minimum 2 / Maximum 10
Force Main	Desired 2 to 7 / Maximum 10

Notes:

1. Unless noted otherwise, criteria shown are recommended based on Akel Engineering Group experience.
2. Based on the 2019 City of Hollister Design Standards.

Due to the hydraulics of a circular conduit, velocity of half-full flows approaches the velocity of nearly full flows. **Table 3.1** lists the minimum slopes, varying by pipe size, in accordance with the City's design standards. The design standards also specify minimum pipe sizes, depending on the peak dry weather flows, as shown on **Table 3.1**.

Changes in Pipe Size

When a smaller gravity wastewater pipe joins a larger pipe, the invert of the larger pipe is generally to maintain the same energy gradient. One of the methods used to approximate this condition includes placing the 80 percent depth point (d/D at 0.8) from both wastewater mains at the same elevation. For master planning purposes, and in the absence of known field data, wastewater main crowns were matched at the manholes.

3.1.2 Force Mains and Lift Stations

The Hazen-Williams formula is commonly used for the design of force mains as follows:

- Hazen Williams Velocity Equation: $V = 1.32 C R^{0.63} S^{0.54}$

Where:

V = mean velocity, fps

C = roughness coefficient

R = hydraulic radius, ft

S = slope of the energy grade line, ft/ft

The value of the Hazen-Williams 'C' varies and depends on the pipe material and is also influenced by the type of construction and pipe age. A 'C' value of 130 was used in this analysis.

The minimum recommended velocity in force mains is at 2 feet per second. The economical pumping velocity in force mains ranges between 3 and 5 fps. A maximum desired velocity is typically around 7 fps and a maximum not-to-exceed velocity is at 10 fps.

The capacities of pump stations are evaluated and designed to meet the peak wet weather flows with one standby pump having a capacity equal to the largest operating unit. The standby pump provides a safety factor in case the duty pump malfunctions during operations and allows for maintenance.

3.2 DRY WEATHER FLOW CRITERIA

Wastewater unit flow factors are coefficients commonly used in planning level analysis to estimate future average daily wastewater flows for areas with predetermined land uses. The unit factors are multiplied by the number of dwelling units or acreages for residential categories, and by the acreages for non-residential categories, to yield the average daily wastewater flow projections.

3.2.1 Unit Flow Factors Methodology

Wastewater unit factors are developed by using water consumption records and applying a return to sewer ratio for each land use to estimate wastewater flow coefficients. There are several methods for developing the unit factors. This analysis relied on the use of the City's water

consumption billing records, which lists the monthly water consumption per customer account, by land use type, to estimate the unit factors within the service area.

3.2.2 Average Daily Wastewater Unit Flow Factors

Wastewater flow factors were based on water demands as extracted from the City's water consumption billing records. A return to sewer ratio was applied to each unadjusted water demand factor for individual land uses, and wastewater flows were balanced to wastewater treatment plant flows. Generally, non-residential land uses return the majority of the water demand to the wastewater collection system. These unit factors were estimated to range from 75 percent to 90 percent return to sewer ratios. The same concept can be applied to single family and multi-family residential lots, which were estimated at 75 percent return to sewer ratio. Low density rural residential lots often have the lowest return to sewer ratio. This is largely due to water lost for landscape irrigation. Rural residential lots were estimated at 40 percent return to sewer ratio. Lastly, unit factors were adjusted to 100 percent occupancy, and rounded.

This analysis generally indicates that existing non-residential land uses have higher flow generation factors than that of residential land uses. The existing unit factor analysis is shown on [Table 3.2](#); the unit factors are shown on [Table 3.3](#).

3.2.3 Peaking Factors

The wastewater collection system is evaluated based on its ability to convey peak wastewater flows. Peaking factors represent the increase in wastewater flows experienced above the average dry weather flows (ADWF). The various peaking conditions are numerical values obtained from a review of historical data and, at times, tempered by engineering judgment.

The peaking conditions that are significant to hydraulic analysis of the wastewater collection system include:

- peak dry weather flows (PDWF)
- peak wet weather flows (PWWF)

Typical values for peaking factors of 2.0 or less are generally used to estimate peak flows at treatment facilities where flow fluctuations are smoothed out during the time of travel in the wastewater collection system, while peaking factors between 3.0 and 4.0 are used to estimate peak flows in the smaller upstream areas of the system where low flow conditions are prone to greater fluctuations.

3.3 WET WEATHER FLOW CRITERIA

The wet weather flow criteria accounts for the infiltration and inflows (I&I) that seep into the City's wastewater collection system during storm events.

Table 3.2 Wastewater Flow Unit Factor Analysis

Wastewater Master Plan
City of San Juan Bautista

Land Use Classification	Existing Development within Service Area (acres)	2019 Average Daily Water Demand Unit Factors ¹		Return to Sewer Ratio	2019 Average Daily Wastewater Flow Unit Factors						
		Annual Consumption (gpd)	Unadjusted Water Unit Factor (gpd/acres)		Wastewater Flows		Wastewater Flows at 100% Occupancy		Wastewater Unit Factor		
					Unadjusted Wastewater Unit Factor (gpd/acres)	Balance to 2019 Flows (gpd)	Vacancy Rate ^{2,3} (gpd/acre)	Projected Flows at 100% Occupancy (gpd)	Recommended Factor ⁴ (gpd/acres)	Balance Using Recommended Unit Factor (gpd)	
Residential											
Low Density Residential - Rural ⁵	74	6,577	89	0.40	36	2,631	9.0%	39	2,868	40	2,955
Low Density Residential - Single Family ⁵	161	111,215	691	0.75	518	83,411	9.0%	565	90,918	570	91,788
Medium / High Density Residential	8	6,717	836	0.75	627	5,037	9.0%	683	5,491	1,125	9,043
Mission Farm RV Park ⁶	12	2,064	169	0.75	127	1,548	9.0%	138	1,688	140	1,712
<i>Subtotal Residential</i>	255	126,573				92,628			100,964		105,498
Non-Residential											
Agriculture	273	0	0	0.00	0	0	0.0%	0	0	0	0
Commercial	20	29,662	1,506	0.90	1,356	26,695	6.0%	1,437	28,297	1,440	28,358
Industrial ^{7,8}	45	17,121	382	0.00	0	0	6.0%	0	0	0	0
Mixed-Use ⁹	0	0	0	0.00	0	0	0.0%	0	0	0	0
Public Facility ¹⁰	43	3,679	85	0.75	64	2,759	0.0%	64	2,759	70	3,017
Non-Flow Generating Public Facility	15	0	0	0.00	0	0	0.0%	0	0	0	0
Earthbound Farm ¹¹	60	-	-	-	442	26,700	0.0%	442	26,700	442	26,700
True Leaf Farms ¹²	30	-	-	-	14	414	0.0%	14	414	14	414
<i>Subtotal - Non-Residential</i>	486	50,461				56,569			58,170		58,490
Other											
Open Space	5	0	0	0	0	0	0.0%	0	0	0	0
Vacant	34	0	0	0	0	0	0.0%	0	0	0	0
Other	2	0	0	0	0	0	0.0%	0	0	0	0
Williamson Act Land	65	0	0	0	0	0	0.0%	0	0	0	0
<i>Subtotal - Other</i>	106	0				0			0		0
Totals					2019 Average Annual Flows						
	848	177,034			Estimated Wastewater Flows	149,196			159,134		163,988
					Measured WWTP Flows ¹³	147,280					



Note:

- 2019 Water Consumption provided by City staff on January 13, 2020.
- Residential vacancy rates sourced from San Benito County 2017-2022 Comprehensive Economic Development Strategy.
- Commercial and Industrial vacancy rates sourced from San Benito County 2010 General Plan.
- Recommended Medium/High Density Residential Wastewater Flow factor based on corresponding recommended water demand factor and assumes a return-to-sewer ratio of 0.75.
- Existing acreage and consumption for low density residential land use was divided into two separate sub-types based on lot size; generally low density residential lots over 1.0 acres were considered Rural while lots under 1.0 acres were considered Single Family.
- Unit factors for Mission Farm RV Park were calculated separately from medium / high density residential land use to account for higher population density than is typical.
- Existing acreage of industrial land use and estimated wastewater flows exclude two users outside of the City's service area: Earthbound Farm & True Leaf Farms. These users operate private facilities that convey flows directly to the WWTP and have been listed separately.
- There are no known industrial users that discharge flows to the wastewater collection system, as a result the RTS for industrial users has been updated accordingly.
- Existing acreage of mixed-use land use was consolidated with its predominant land use designation.
- Existing acreage of public facility land use excludes non-demand generating parcels, such as the cemetery and wastewater treatment plant.
- Earthbound Farms wastewater discharge provided by City staff via email on June 5, 2020.
- True Leaf Farms wastewater discharge provided by City staff on June 8, 2020.
- Measured WWTP flows provided by City staff on February 18, 2020.

Table 3.3 Recommended AAF Wastewater Unit Factors
 Wastewater Master Plan
 City of San Juan Bautista

Land Use Type	Recommended Unit Factor (gpd/acre)
Low Density Residential - Rural	40
Low Density Residential - Single Family	570
Medium / High Density Residential	1,125
Mission Farm RV Park	140
Commercial	1,440
Industrial ¹	1,000
Public Facility	70



7/7/2020

Notes:

1. Recommended Wastewater Unit Factor for Industrial Land Use based on Akel Engineering Group Experience

3.3.1 Infiltration and Inflow

Groundwater infiltration and inflow is associated with extraneous water entering the wastewater collection system through defects in pipelines and manholes. Infiltration occurs when groundwater rises or the soil is saturated due to seasonal factors such as a storm event which causes an increase in flows in the wastewater collection system. The ground water will enter the wastewater collection system through cracks in the pipes or deteriorating manholes. Inflow occurs when surface water enters the wastewater collection system from storm drain cross connections, manhole covers, or roof/footing drains. [Figure 3.1](#) was developed by King County, Washington and was included in this chapter to illustrate the typical causes of infiltration and inflow.

There are several accepted methodologies for estimating infiltration and inflows (I&I). These include:

- **Methodology 1.** Based on Acreages. In this methodology, factors that may range between 400 and 1,500 gallons per day (gpd) or more are applied to acreages for estimating the I&I component.
- **Methodology 2.** Based on Linear Feet of Pipe. In this methodology, factors that may range between 12 and 30 or more gallons per day per inch diameter per 100 linear feet (gpd/inch diameter/100LF) are applied to linear feet of wastewater gravity pipelines.
- **Methodology 3.** Based on a percentage of Average Dry Weather Flows. In this methodology, Infiltration and Inflows (I&I) are calculated based on a percentage of the average dry weather flow.
- **Methodology 4.** Based on flow monitoring data. In this methodology, infiltration and inflows are determined by analyzing flow monitoring data of current and past flow monitoring efforts.

This capacity analysis and master plan based the infiltration and inflow on historical WWTP flows and associated rainfall events to reflect behavior of the wastewater collection system.

3.3.2 Wastewater Collection System Flow Monitoring

Flow monitoring was not completed as a part of the Wastewater Master Plan. The capacity analysis for rainfall dependent infiltration and inflow were based on historical WWTP flows and rainfall events that were used to validate the hydraulic model.

3.3.3 10-Year 24-Hour Design Storm

A synthetic design storm is typically used to evaluate the wastewater collection system's response during wet weather flow conditions. The design storm information was collected from the National Oceanic and Atmospheric Administration (NOAA) Atlas 14 Volume 6 ([Table 3.4](#)).

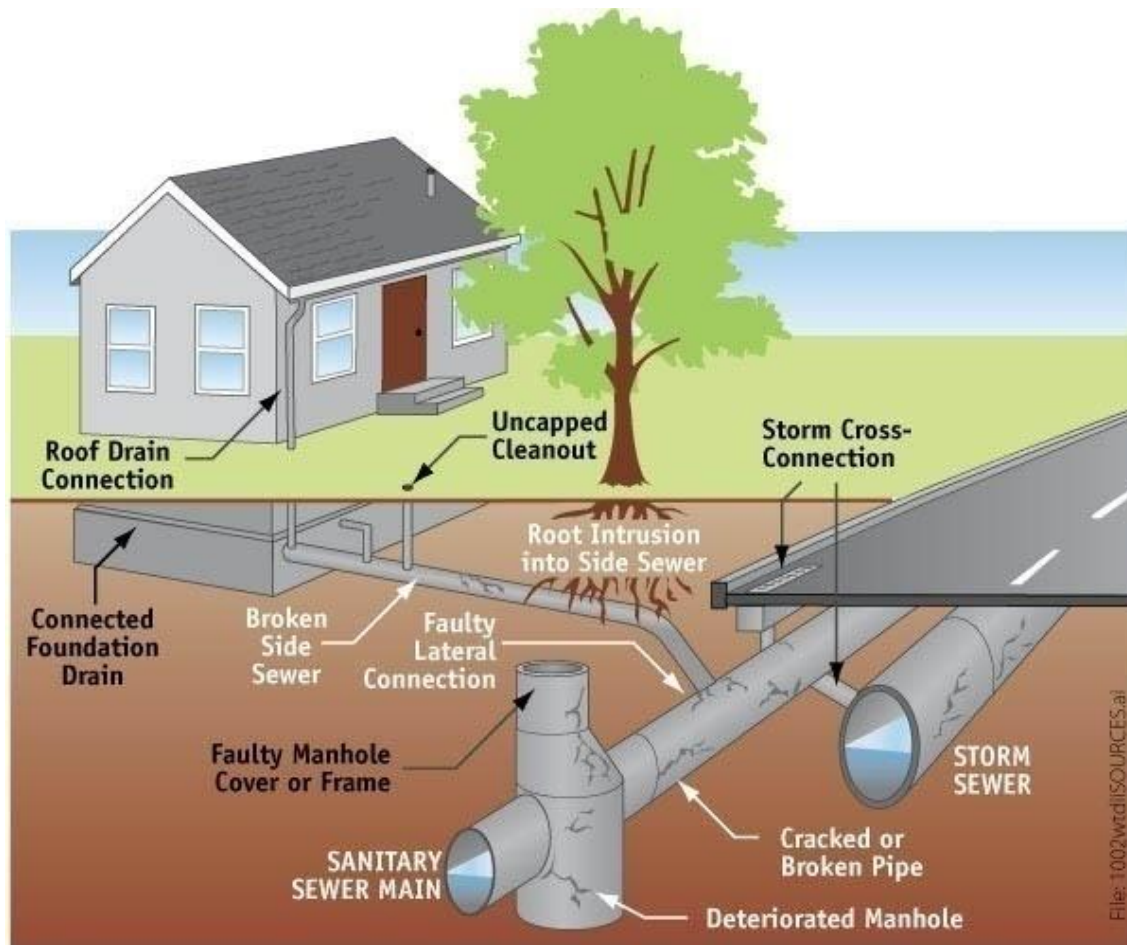

LEGEND

**Inflow Sources
(Black Text)**

**Infiltration Sources
(White Text)**

**Figure 3.1
Infiltration and Inflow
Sources**

Wastewater Master Plan
City of San Juan Bautista



Source: King County, WA
<http://www.kingcounty.gov/environment/wastewater/II/What.aspx?print=1>

January 6, 2020

- **10-Year Frequency.** Industry standards include design storms that range between 5-year and 20-year events. Based on current regulatory trends, a 10-year storm event was chosen for the City to evaluate the capacity adequacy of the wastewater collection system.
- **24-Hour Duration.** Peak flows from a storm event are usually caused by brief intense rains, that can happen as part of an individual event or as a portion of a larger storm. The 24-hour storm duration is longer than needed to determine peak flow but aids in identifying infiltration and inflows a wastewater collection system may experience during a storm event.
- **Balanced Rainfall Centered Distribution.** The National Resources Conservation Service, previously known as the Soil Conservation Service, has developed rainfall distributions for wide geographic regions based on traditional Depth-Duration-Frequency (DDF) rainfall data. In this methodology, the highest rainfall intensity is placed at the center of the storm. Incrementally lower intensities are placed on alternating sides of the peak.

Thus, the NOAA Atlas 14 Depth Duration Frequency (DDF), 10-year 24-hour (10yr-24hr) design storm, with a balanced rainfall distribution, was used to evaluate the capacity adequacy of the City's wastewater collection system during wet weather flow conditions.

The selected 10-year 24-hour design storm was further compared to local historical storm events in proximity to San Juan Bautista, between January 2017 and February 2017 based on available data. The January 2017 and February 2017 24-hour rainfall events experienced 1.02 and 1.68 inches of rainfall respectively while the 10-year 24-hour storm event estimates a total rainfall amount of 3.53 inches ([Table 3.4](#)).

Table 3.4 Precipitation Depth-Duration-Frequency

Wastewater Master Plan

City of San Juan Bautista

Duration	1-Year		2-Year		5-Year		10-Year		25-Year		100-Year	
	(in)	(in/hr)	(in)	(in/hr)	(in)	(in/hr)	(in)	(in/hr)	(in)	(in/hr)	(in)	(in/hr)
5-min	0.12	1.42	0.14	1.70	0.18	2.12	0.21	2.50	0.26	3.06	0.34	4.03
10-min	0.17	1.01	0.20	1.22	0.25	1.52	0.30	1.79	0.37	2.19	0.48	2.89
15-min	0.21	0.82	0.25	0.99	3.00	4.00	5.00	6.00	7.00	28.00	0.58	8.00
30-min	0.28	0.56	0.34	0.68	0.42	0.84	0.50	0.99	0.61	1.21	0.80	1.60
1-hr	0.39	0.39	0.48	0.48	0.59	0.59	0.70	0.70	0.85	0.85	1.12	1.12
2-hr	0.60	0.30	0.72	0.36	0.89	0.44	1.04	0.52	1.26	0.63	1.65	0.83
3-hr	0.75	0.25	0.91	0.30	1.12	0.37	1.31	0.44	1.58	0.53	2.06	0.69
6-hr	1.03	0.17	1.25	0.21	1.56	0.26	1.82	0.30	2.21	0.37	2.86	0.48
12-hr	1.33	0.11	1.68	0.14	2.15	0.18	2.54	0.21	3.09	0.26	3.98	0.33
24-hr	1.71	0.07	2.25	0.09	2.96	0.12	3.53	0.15	4.32	0.18	5.54	0.23

A K E L
ENGINEERING GROUP, INC.

4/1/2020

Note:

1. Source: NOAA Atlas 14 Volume 6 Version 2 for San Juan Bautista.

CHAPTER 4 – EXISTING WASTEWATER COLLECTION FACILITIES

This chapter provides a description of the City’s existing wastewater collection system facilities including gravity trunks, force mains, and lift stations. The chapter also includes a brief description of the City’s WWTP, which treats and disposes of the wastewater for the City.

4.1 WASTEWATER COLLECTION SYSTEM OVERVIEW

The City provides wastewater collection services to more than 900 residential, commercial, industrial, and institutional accounts. The City’s existing wastewater collection system consists of approximately 9.3 miles of gravity mains and force mains, and 5 lift stations that convey flows to the City’s WWTP as summarized on [Table 4.1](#)

The City’s existing wastewater collection system is shown in [Figure 4.1](#), which displays the existing system by pipe size. This figure provides a general color coding for the collection mains, as well as labeling the existing lift stations.

4.2 WASTEWATER COLLECTION TRUNKLINE

The City’s wastewater collection system has a single primary trunk that collects and conveys wastewater flows to the WWTP. The primary trunk begins along The Alameda near Old San Juan Hollister Road and collects flows as it travels along Fourth Street, Tualalami Street, and Third Street until the flows reach the WWTP location.

4.3 LIFT STATIONS

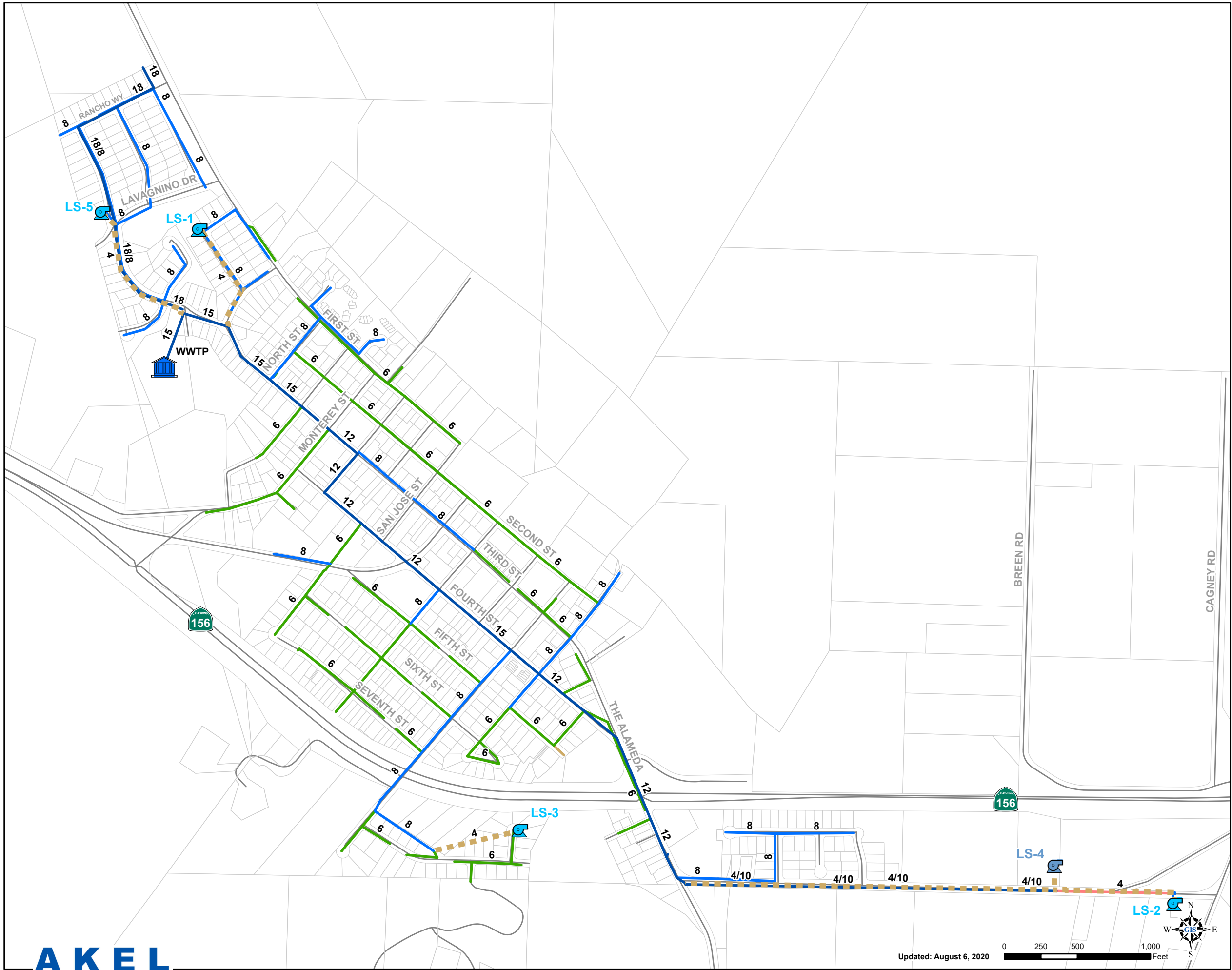

When routing flows by gravity is not possible due to adverse grades, lift stations are used to pump flows. The City currently maintains and operates five lift stations in the wastewater collection system, as summarized on [Table 4.1](#) and shown on [Figure 4.1](#). [Table 4.1](#) also includes wet well capacities, pumping head, and pumping capacities of each lift station. The modeled lift stations are listed as follows:

- **Lift Station 1:** This lift station services the area located along Ahwahnee Street, First Street to the east, and Donner Street to the south. This lift station includes two duty pumps and one standby pump. The pump station has a firm capacity of 40 gallons per minute (gpm) and a total capacity of 60 gpm. The pump discharges into a 4-inch force main that heads south along Ahwahnee Street and Donner Street.
- **Lift Station 2:** This lift station services the area located along Old San Juan Hollister Road. This lift station includes a duty pump and a standby pump. The pump station has a firm capacity of 200 gpm and a total capacity of 200 gpm. The pump discharges into a 4-inch force main that heads west along Old San Juan Hollister Road.



Legend

Existing System

-  WWTP
-  Lift Station
-  Private Lift Station

Gravity Mains by Diameter



-  Unknown
-  4"
-  6"
-  8"
-  10" and Greater
-  Force Mains
-  Streets
-  Parcels

Figure 4.1
Existing System
 Wastewater Master Plan
 City of San Juan Bautista

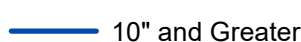

Table 4.1 Existing System Inventory

Wastewater Master Plan
City of San Juan Bautista

Existing Wastewater Collection Facilities				
Facility Name	Facility Information			
	Lift Stations ¹			
	Number of Pumps	Pump Capacity	Wet Well Capacity	Head
LS-1 (SJB WWTP)	3 @ 20 gpm	60 gpm	1,500 gal	65.0 ft
LS-2 (Old San Juan Hollister Rd & Mission Vineyard Rd)	2 @ 200 gpm	400 gpm	4,016 gal	46.0 ft
LS-3 (Lang Ct. Cul-de-sac)	2 @ 67 gpm	134 gpm	2,220 gal	20.0 ft
LS-4 (Mission Farm RV Park)	Private Lift Station			
LS-5 (Rancho Vista Lift Station)	2 @ 100 gpm	200 gpm	4,441 gal	31.2 ft
	Existing Pipes, by Diameter ²			
Diameter (in)	Total Length (LF)	(mi)	% of Total System	
Gravity Main				
Unknown Diameter	810	0.2	1.6%	
4	96	0.0	0.2%	
6	16,985	3.2	34.4%	
8	14,610	2.8	29.6%	
10	2,607	0.5	5.3%	
12	4,051	0.8	8.2%	
15	1,930	0.4	3.9%	
18	2,288	0.4	4.6%	
Subtotal - Gravity Main	43,377	8.22	87.9%	
Force Main				
4	5,886	1.1	11.9%	
8	69	0.0	0.1%	
Subtotal - Force Main	5,954	1.1	12.1%	
Total	49,331	9.3	100.0%	

Notes:

1. Lift Station information provided by City staff on August 3, 2020.
2. Source: San Juan Bautista Utilities Shapefile provided by City staff on November 11, 2019.

- **Lift Station 3:** This lift station services the area located along Lang Court, Lang Street to the west, and Stephens Drive to the south. This lift station includes a duty pump and a standby pump. The pump station has a firm capacity of 67 gpm and a total capacity of 135 gpm. The pump discharges into a 4-inch force main that heads west north of Lang Street.
- **Lift Station 4:** This lift station services the Mission Farm RV Park north of Old San Juan Hollister Road. This is a private lift station and pumping capacities and wet well information was not provided as a part of the Master Plan data collection process. The pump discharges into an unknown diameter force main that heads west along Old San Juan Hollister Road.
- **Lift Station 5:** This lift station services the Rancho Vista development area located along Lavagnino Drive to the east, Rancho Way to the north, and Third Street to the north and south. This lift station includes one duty pump and one standby pump. The pump station has a firm capacity of 100 gpm and a total capacity of 200 gpm. The pump discharges into a 4-inch force main that heads south along Third Street.

4.4 WASTEWATER TREATMENT PLANT

Akel Engineering retained the services of Stantec Consulting Services Inc (Stantec) to generate an engineering report that investigates the existing WWTP and develop recommendations to bring the WWTP into compliance with regulatory standards ([Appendix A](#)). The following text summarizing the existing WWTP facility was extracted from various sections of Stantec's engineering report.

The existing WWTP is located at 1300 Third Street in San Juan Bautista. The City's WWTP is an 0.2 mgd facility that provides sanitary wastewater collection, treatment, and disposal for the community. According to Stantec's report, *the existing WWTP is a tertiary treatment facility that includes a mechanical screen and influent pump station, sequencing batch reactor pond (SBR, located in Pond 1), flow equalization tanks, a denitrification pond (located in Pond 2C with floating media), pressure sand filters, and ultraviolet (UV) disinfection. Sludge is stored in lagoons (Pond 2A and 2B). The original plant was a facultative pond plant. The last major improvement project, in 2010, upgraded Pond 1 to an aerated pond that functions as SBRs and split Pond 2 into three cells, which include the polishing pond and two sludge storage lagoons. The 2010 upgrade project also added a mechanical basket screen, a new dual media pressure filtration system, and UV disinfection system. In 2018, the City removed 30-years of accumulated sludge from Pond 2, to accommodate continued operation of the treatment plant. The tertiary treatment facility is only designed to handle 0.2 mgd, while there is some buffering capacity available in the SBR (1.6 MG), the available volume is not enough to equalize the excess daily flow during peak flow conditions. For long term compliance, the tertiary treatment train needs to be expanded to accommodate higher flow rates.*

CHAPTER 5 –WASTEWATER FLOWS

This chapter summarizes historical wastewater flows experienced at the City’s WWTP and defines flow terminologies relevant to this evaluation. This chapter discusses the design flows used in the hydraulic modeling effort and capacity evaluation. The design flows include the existing condition (existing customers) and buildout development conditions.

5.1 FLOWS AT THE CITY OF SAN JUAN BAUTISTA WWTP

The wastewater flows collected and treated at the City of San Juan Bautista WWTP vary monthly, daily, and hourly. While the dry weather flows are influenced by customer uses, the wet weather flows are influenced by the severity of storm events and the condition of the system.

Flow data influent to the City of San Juan Bautista WWTP was obtained from City operation staff. The flow data covered a period from 2009 to 2018. From this data monthly, daily, and peak daily flows (if available), were determined as summarized on [Table 5.1](#).

The following definitions are intended to document relevant terminologies shown on [Table 5.1](#):

- **Average Annual Flow (AAF).** The average annual flow is the total annual flow, or average monthly flow, for a given year, expressed in daily or other time units. This flow includes the combined average of the average dry weather flow (ADWF) and average wet weather flow (AWWF).
- **Average Dry Weather Flow (ADWF).** The average dry weather flow occurs on a daily basis during the dry weather season, with no evident reaction to rainfall. The ADWF also includes the Base Wastewater Flow (BWF). The base wastewater flow is the average flow that is generated by residential, commercial, and industrial users. The flow pattern from these users varies depending on land use types.
- **Average Wet Weather Flow (AWWF).** This average wet weather flow occurs on a daily basis during the wet weather season. In addition to the flow components in the ADWF, the AWWF includes infiltration and inflow from storm rainfall events.
- **Maximum Month Dry Weather Flow (MMDWF).** This maximum month flow occurs during the dry weather season.
- **Maximum Month Wet Weather Flow (MMWWF).** This maximum month flow occurs during the wet weather season.

Table 5.1 Wastewater Treatment Plant - Historical Flow Data and Peaking Factors

Wastewater Master Plan
City of San Juan Bautista

Year	Average Annual Flow (AAF) (mgd)	Percentage Change	Seasonal Average		Maximum Month		Maximum Day	
			ADWF ³ (mgd)	AWWF ⁴ (mgd)	MMDWF (mgd)	MMWWF (mgd)	MDDWF (mgd)	MDWWF (mgd)
Historical Flows								
2009	0.19		0.20	0.19	0.22	0.21	0.30	0.41
2010	0.20	0.9%	0.20	0.20	0.23	0.24	0.42	0.36
2011	0.19	-5.1%	0.18	0.19	0.21	0.24	-	-
2012	0.16	-14.5%	0.16	0.16	0.18	0.17	0.20	0.30
2013	0.16	1.9%	0.16	0.16	0.17	0.18	0.20	0.24
2014	0.18	8.2%	0.18	0.17	0.26	0.20	0.31	0.41
2015	0.16	-11.6%	0.17	0.14	0.18	0.18	0.22	0.28
2016	0.11	-26.5%	0.12	0.11	0.12	0.13	0.15	0.29
2017	0.17	49.7%	0.19	0.16	0.20	0.21	0.30	0.46
2018	0.12	-28.9%	0.12	0.12	0.13	0.13	-	-
Historical Peaking Factors (Applied to ADWF)								
2009	0.95	-	1.00	0.92	1.08	1.01	1.46	1.99
2010	1.00	-	1.00	1.00	1.15	1.21	2.12	1.84
2011	1.02	-	1.00	1.03	1.12	1.30	-	-
2012	0.98	-	1.00	0.96	1.08	1.06	1.21	1.85
2013	1.00	-	1.00	0.99	1.03	1.12	1.20	1.49
2014	0.99	-	1.00	0.97	1.44	1.14	1.74	2.29
2015	0.90	-	1.00	0.83	1.07	1.02	1.28	1.60
2016	0.99	-	1.00	0.98	1.07	1.10	1.30	2.47
2017	0.92	-	1.00	0.86	1.09	1.14	1.62	2.50
2018	1.02	-	1.00	1.03	1.06	1.08	-	-
Recommended Evaluation Peaking Factor								
			Recommended Peaking Factor		1.44	1.30	1.75	2.50



8/6/2020

Notes :

1. Source: Average, minimum, and maximum monthly flow data for 2009-2010, and 2012-2017 provided by City staff on February 18, 2020.
2. Source: Average monthly flow data for 2011 and 2018 provided by City staff on April 23, 2020.
3. Dry weather months include months from May to September.
4. Wet weather months include months from October to April.
5. Definitions are as follows:
 - AAF - Average Annual Flow (annual flow, expressed in daily or other time units)
 - ADWF - Average Dry Weather Flow (average flow that occurs on a daily basis during the dry weather season)
 - AWWF - Average Wet Weather Flow (average flow that occurs on a daily basis during the wet weather season)
 - MMDWF - Maximum Month Dry Weather Flow (maximum month flow during the dry weather season)
 - MMWWF - Maximum Month Wet Weather Flow (maximum month flow during the wet weather season)
 - MDDWF - Maximum Day Dry Weather Flow (highest measured daily flow that occurs during a dry weather season)
 - MDWWF - Maximum Day Wet Weather Flow (highest measured daily flow that occurs during a wet weather season)

- **Maximum Day Dry Weather Flow (MDDWF).** This is the highest measured daily flow that occurs during a dry weather season.
- **Maximum Day Wet Weather Flow (MDWWF).** This is the highest measured daily flow that occurs during a wet weather season.
- **Peak Dry Weather Flow (PDWF).** This is the highest measured hourly flow that occurs during a dry weather season.
- **Peak Wet Weather Flow (PWWF).** This is the highest measured hourly flow that occurs during a wet weather season.

Table 5.1 shows the average annual flows (AAF) collected at the City of San Juan Bautista WWTP have decreased from 0.19 mgd in 2009 to 0.12 mgd in 2018, which is a decrease of approximately 37%. In general, the AAF flows have decreased from 2010 to 2015, and decreased by 29 % between 2017 and 2018.

In addition to listing the 2009-2018 flows, and for comparison purposes, the table calculates the peaking factors applied to the corresponding average dry weather flows (ADWF) for each year. During wet weather flows in 2017, the maximum daily volume (MDWWF) contributed by the City at the City of San Juan Bautista WWTP was 2.5 times higher than the average dry weather flow for the same year.

5.2 EXISTING WASTEWATER FLOWS

The existing wastewater flows represented in this Master Plan were based on the City’s water consumption billing records. The number of acres and corresponding wastewater flows are summarized on **Table 5.2**.

There are two users that fall outside the City limits that contribute flow to the existing wastewater collection system. True Leaf Farms located near Prescott Road and San Juan Highway and Taylor/Earthbound Farms located near San Justo Road and San Juan Highway both contribute flow to the existing wastewater collection system. The flow for both users is conveyed by private infrastructure to the City’s 6-inch gravity main along Thomas Lane northeast of First Street (**Figure 4.1**). The acreage and corresponding wastewater flows for both users are respectively summarized on **Table 3.2** and **Table 5.2**.

5.3 BUILDOUT WASTEWATER FLOWS

The land use methodology was used to estimate the buildout wastewater flows from the City’s Planning Area and to be consistent with the General Plan. **Table 5.2** documents the total acreages for residential and non-residential land use, and the undeveloped lands designated for urbanization. The undeveloped lands were multiplied by the corresponding unit flow factor to estimate the wastewater flows. The buildout average daily flows were calculated at 0.43 mgd.

Table 5.2 Future Wastewater Flows

Wastewater Master Plan
City of San Juan Bautista

Land Use Classification	Wastewater Unit Factor (gpd/acre)	Total Wastewater Flows			Buildout of Service Area	
		Existing Unchanged ^{1,2} (acres)	Redeveloped Area ^{1,2} (acres)	New Development (acres)	Total Area (acres)	Average Daily Flow (gpd)
Residential						
Low Density Residential - Rural	40	72.9	0.0	0.0	72.9	2,914
Low Density Residential - Single Family	570	125.1	22.6	16.0	163.6	93,243
Medium Density Residential	1,125	7.2	36.5	4.9	48.6	54,650
Mission Farm RV Park	140	12.2	0.0	0.0	12.2	1,712
Subtotal - Residential		217.4	59.0	20.9	297.2	152,519
Non-Residential						
Commercial	1,440	18.4	117.0	6.1	141.5	203,761
Industrial ^{3,4}	1,000	44.8	34.7	0.0	40.1	40,128
Earthbound Farm ⁵	-	60.4	0.0	0.0	60.4	26,700
True Leaf Farms ⁶	-	29.5	0.0	0.0	29.5	414
Public Facility ⁷	70	57.5	10.5	2.4	55.1	3,855
Subtotal - Non-Residential		210.6	162.2	8.5	326.6	274,857
Total						
Future Flows		427.9	221.2	29.3	623.9	427,377



7/7/2020

Notes:

1. Land Use areas based on parcel shapefile downloaded from San Benito County Website (11/05/2019).
2. Developed and Undeveloped areas based on parcel shapefile received from City Staff January 16, 2020.
3. Unit Factor for Industrial Land Use is recommended based on Akel Engineering Group experience.
4. Industrial acreages shown exclude Earthbound Farms, True Leaf Farms, and Amycel Mushroom Farms.
5. Earthbound Farms wastewater discharge provided by City staff via email on June 5, 2020.
6. True Leaf Farms wastewater discharge provided by City staff on June 8, 2020.
7. Public facility acreages shown exclude non-flow generating parcels.

The two users that fall outside the City limits, Taylor/Earthbound Farms and True Leaf Farms were assumed to contribute the same buildout wastewater flows as their existing condition flows as shown on [Table 5.2](#). Both facilities are developed and there was no indication of additional flows being contributed by these uses in the buildout scenario during the time of this WWMP's preparation.

5.4 WASTEWATER COLLECTION SYSTEM DESIGN FLOWS

The design flows most relevant in this capacity analysis of the wastewater collection system, in addition to the Maximum Day Dry Weather Flows (MDDWF), include the peak dry weather flow (PDWF) and peak wet weather flow (PWWF).

- **Peak Dry Weather Flow (PDWF).** The PDWF is used for evaluating the capacity adequacy of the wastewater collection system, and to meet the criteria set forth in the previous chapter and in the City standards.
- **Peak Wet Weather Flow (PWWF).** The PWWF is used for designing the capacity of the wastewater collection system, while allowing acceptable amounts of surcharging in the system.

The design flows used in evaluating the capacity adequacy of the wastewater collection system is summarized on [Table 5.3](#). The table lists the maximum day and peak hour flows for dry and wet weather conditions. PDWF and PWWF used for evaluating the existing collection system were estimated at 0.51 mgd and 1.74 mgd, respectively. The PDWF and PWWF used for designing the General Plan buildout system, including growth, were estimated at 1.39 mgd and 2.25 mgd, respectively.

Table 5.3 Design Flows

Wastewater Master Plan

City of San Juan Bautista

Description	Peak Dry Weather Flow (mgd)	Peak Wet Weather Flow (mgd)
Existing	0.51	1.74
Buildout	1.39	2.25



8/6/2020

Notes:

1. Flows shown are extracted from wastewater system hydraulic model and reflect diurnal flow variations and flow attenuation.

CHAPTER 6 – HYDRAULIC MODEL DEVELOPMENT

This chapter describes the development and validation of the City's wastewater collection system hydraulic model. The City's hydraulic model was used to evaluate the capacity adequacy of the existing system and to plan its expansion to service anticipated future growth.

6.1 OVERVIEW

Hydraulic modeling analysis has become an effectively powerful tool in many aspects of wastewater collection planning, design, operation, management, emergency response planning, and system reliability analysis and evaluations. The City's hydraulic model was used to evaluate the capacity adequacy of the existing system and to plan its expansion to service anticipated growth.

6.2 HYDRAULIC MODEL SOFTWARE SELECTION

The City's hydraulic model combines information on the physical characteristics of the wastewater collection system (pipelines, manholes, and lift stations) and operational characteristics (how they operate). The hydraulic model then performs calculations and solves series of equations to simulate flows in pipes, including backwater calculations for surcharged conditions.

There are several network analysis software products released by different manufacturers that can equally perform the hydraulic analysis satisfactorily. The selection of a particular software depends on user preferences, the wastewater collection system's unique requirements, and the costs for purchasing and maintaining the software.

The hydraulic modeling software used for evaluating the capacity adequacy of the City's wastewater collection system, InfoSWMM by Innovyze Inc., utilizes the fully dynamic St. Venant's equation which has a more accurate engine for simulating backwater and surcharge conditions, in addition to having the capability for simulating manifolded force mains. The software also incorporates the use of the Manning Equation in other calculations including upstream pipe flow conditions. The St Venant's and Manning's equations are discussed in the System Performance and Design Criteria chapter.

6.3 HYDRAULIC MODEL DEVELOPMENT

Developing the hydraulic model included system skeletonization, digitizing and quality control, developing pipe and manhole databases, and wastewater loading allocation.

6.3.1 Skeletonization

Skeletonizing the model refers to the process where pipes not essential to the hydraulic analysis of the system are stripped from the model. Skeletonizing the model is useful in creating a system that accurately reflects the hydraulics of the pipes within the system. In addition, skeletonizing the model will reduce complexities of large models, which will also reduce the time of analysis while maintaining accuracy, but will also comply with the limitations imposed by the computer program.

The hydraulic model for the City of San Juan Bautista was skeletonized to include the pipelines essential to the hydraulic analysis. By comparison, the total system includes approximately 9.3 miles of pipe, whereas the hydraulic model includes approximately 8.1 miles of pipelines. The modeled pipes included pipes 6-inches in diameter and larger, in addition to some critical smaller gravity wastewater pipes. The inventory of pipelines included in the hydraulic model is approximately 86 percent of the overall system.

6.3.2 Digitizing and Quality Control

The City's existing wastewater collection system was digitized in GIS using several sources of data and various levels of quality control. The data sources included the City's existing system as documented in GIS drawings and schematics provided by City staff.

After reviewing the available data sources, the hydraulic model was built and verified by City staff. Using the available wastewater collection system data this master plan developed the wastewater collection system in GIS. Resolving discrepancies in data sources was accomplished by graphically identifying identified discrepancies and submitting it to City staff for review and comments. City comments were incorporated in the verified model.

6.3.3 Pipe and Manholes

Computer modeling requires the compilation of large numerical databases that enable data input into the model. Detailed physical aspects, such as pipe size, ground elevation, invert elevations, and pipe lengths contribute to the accuracy of the model.

Pipes and manholes represent the physical aspect of the system within the model. A manhole is a computer representation of a place where wastewater flows may be allocated into the hydraulic system, while a pipe represents the conveyance aspect of the wastewater flows. In addition, selected lift station capacity and design head settings were also included into the hydraulic model.

6.3.4 Load Allocation

Load allocation consists of assigning wastewater flow to the appropriate manholes (nodes) in the model. The goal is to distribute the loads throughout the model to best represent actual system response.

The existing loading allocation was based off of the water billing records. Using GIS, each customer account was geocoded and spatially joined within the existing wastewater collection

system. Wastewater loads were developed by combining the flow factors developed in Chapter 3 with the water billing records for the City. The calculated loads were allocated to the nearest manhole that serves the corresponding customers.

Wastewater loads from each anticipated future development, as presented in previous chapters, were also allocated to the model for the purpose of sizing the required future facilities. The loads from the Urban Growth Boundary were allocated based on proposed land use and the land use acreages. As many of the areas were very large in size, the loads were allocated evenly to the loading manholes within each area. Infill areas, redevelopment areas, and vacant lands were also included in the future load allocation.

6.4 MODEL OPERATIONAL VALIDATION

Model validation is intended to instill a level of confidence in the flows that are simulated, and it generally consists of comparing model predictions to historical WWTP flows, and making necessary adjustments. Lift station capacities were documented and City staff provided feedback to ensure the model appropriately represents the operation characteristics of the existing wastewater collection system with the available operational data. Due to a lack of SCADA implementation, the existing system operational controls are currently based on Akel Engineering experience as there was no wet well levels, pump controls, or flow monitoring data received as part of the WWMP. System diurnal patterns based on Akel experience are shown on [Figure 6.1](#). In the future if SCADA control is implemented, it is recommended that the hydraulic model be updated.

The validated hydraulic model was used as an established benchmark in the capacity evaluation of the existing wastewater collection system. The model was also used to identify improvements necessary for mitigating existing system deficiencies and for accommodating future growth. This valuable investment will continue to provide benefits to the City as future planning issue or other operational conditions surface. It is recommended that the model be maintained and updated with recent construction to preserve its integrity.

Weekday Diurnal

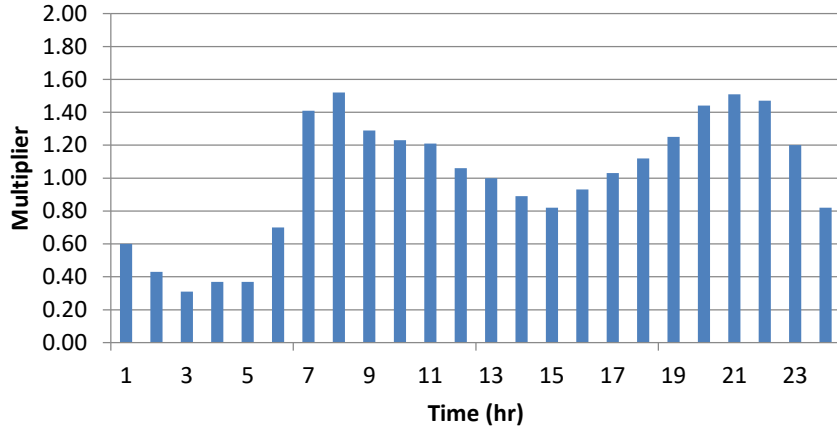

Weekend Diurnal

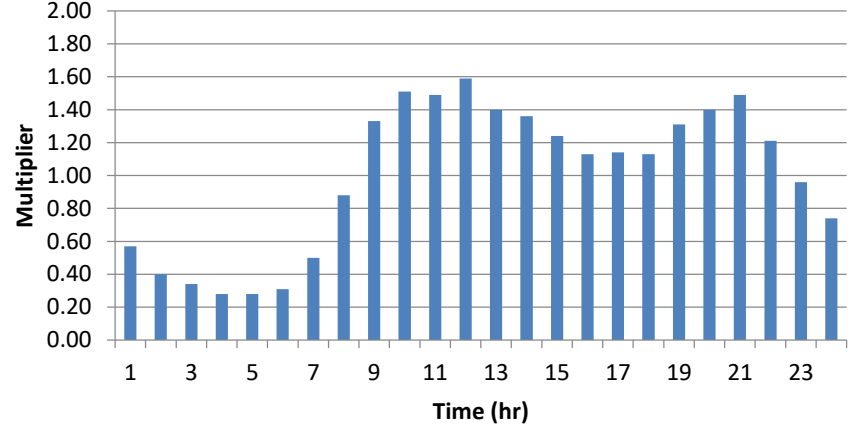

Weekly Diurnal

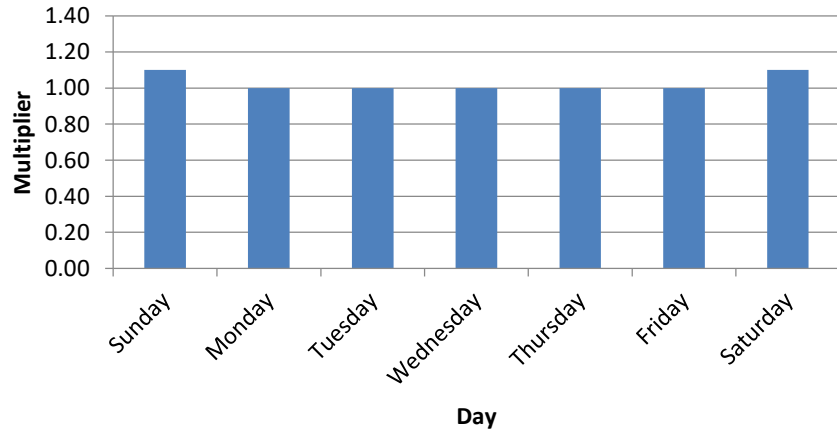

LEGEND

— Model Diurnal

Notes:

- 1. System Diurnals based on Akel Engineering Group experience.

Figure 6.1
System Diurnals

Wastewater Master Plan
City of San Juan Bautista



CHAPTER 7 - EVALUATION AND PROPOSED IMPROVEMENTS

This section presents a summary of the wastewater collection system evaluation and identifies improvements needed to mitigate existing deficiencies, as well as improvements needed to expand the system and service growth.

7.1 OVERVIEW

The developed hydraulic model was used for evaluating the wastewater collection system for capacity deficiencies during peak dry weather flows (PDWF) and peak wet weather flows (PWWF). The analysis duration was established at 24 hours for analyses.

The criteria used for evaluating the capacity adequacy of the wastewater collection system facilities (gravity mains, force mains, and lift stations) were discussed and summarized in the System Performance and Design Criteria chapter.

7.2 EXISTING COLLECTION SYSTEM CAPACITY EVALUATION

The system performance and design criteria summarized, on [Table 3.1](#), were used as a basis to judge the adequacy of capacity for the existing wastewater collection system. The design flows simulated in the hydraulic model for existing conditions were summarized on [Table 5.3](#) and are listed as follows:

- Existing PDWF = 0.51 mgd
- Existing PWWF = 1.74 mgd

During the peak dry weather simulations, the maximum allowable pipe d/D criteria for new pipes (d/D ratio of 0.75) for was used. For existing pipes, the criteria was relaxed to allow a maximum d/D ratio of 0.90 (full pipe capacity) to prevent unnecessary pipe replacements. During the peak wet weather simulations, capacity deficiencies included pipe segments with a hydraulic grade line (HGL) that rises within five feet of the manhole rim elevation.

In general, the hydraulic model indicated that the wastewater collection system exhibited acceptable performance to service the existing customers during both peak dry weather flows ([Figure 7.1](#)) and peak wet weather flows ([Figure 7.2](#)), with exceptions noted in the following sections.

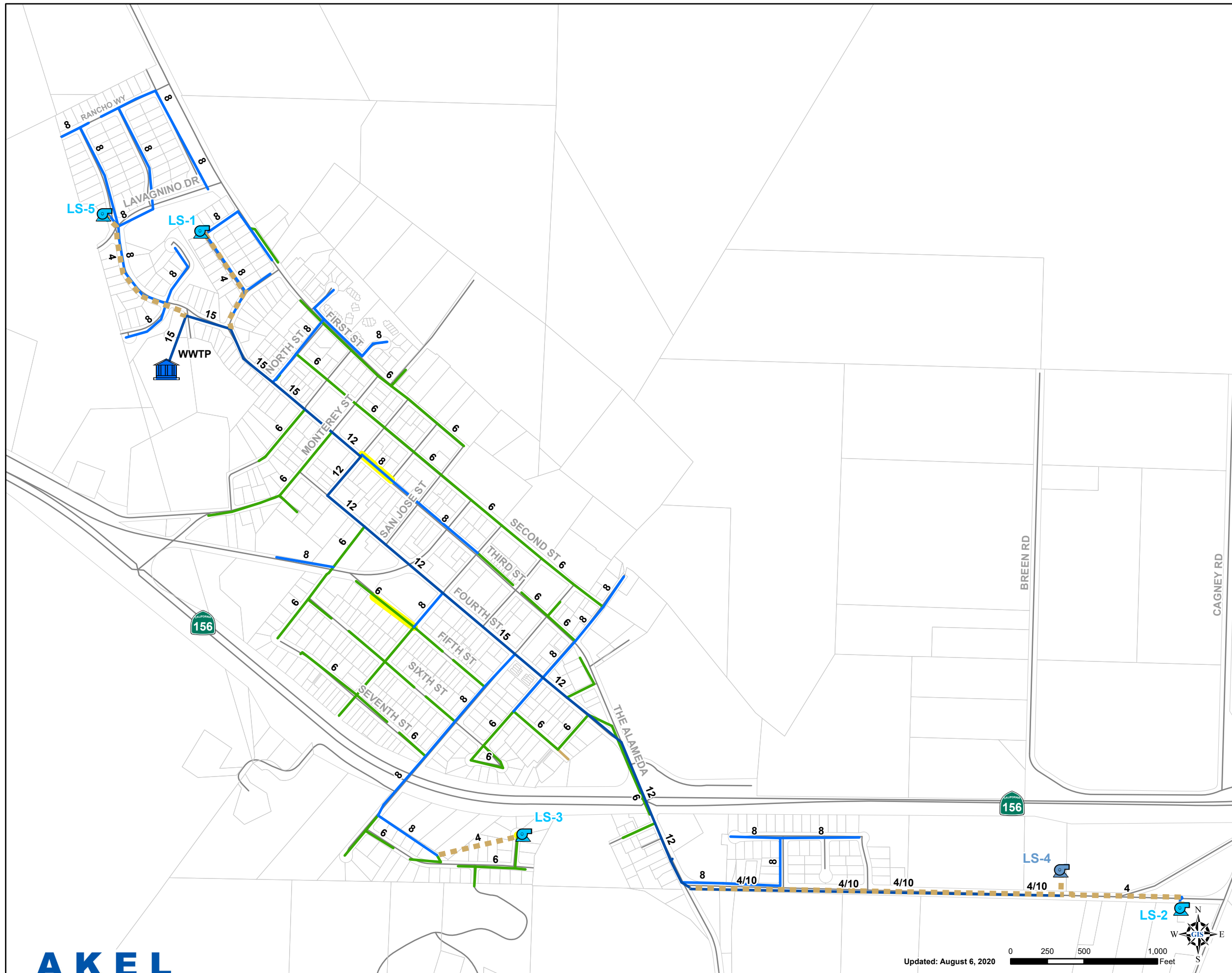

Legend

Pipe d/D

- d/D > 0.90
- d/D 0.75 - 0.90
- d/D 0.50 - 0.75

Existing System

- WWTP
- Lift Station
- Private Lift Station

Gravity Mains by Diameter

- 4"
- 6"
- 8"
- 10" and Greater

Force Mains

Streets

Parcels

Figure 7.1
Existing System Analysis
for PDWF

Wastewater Master Plan
 City of San Juan Bautista



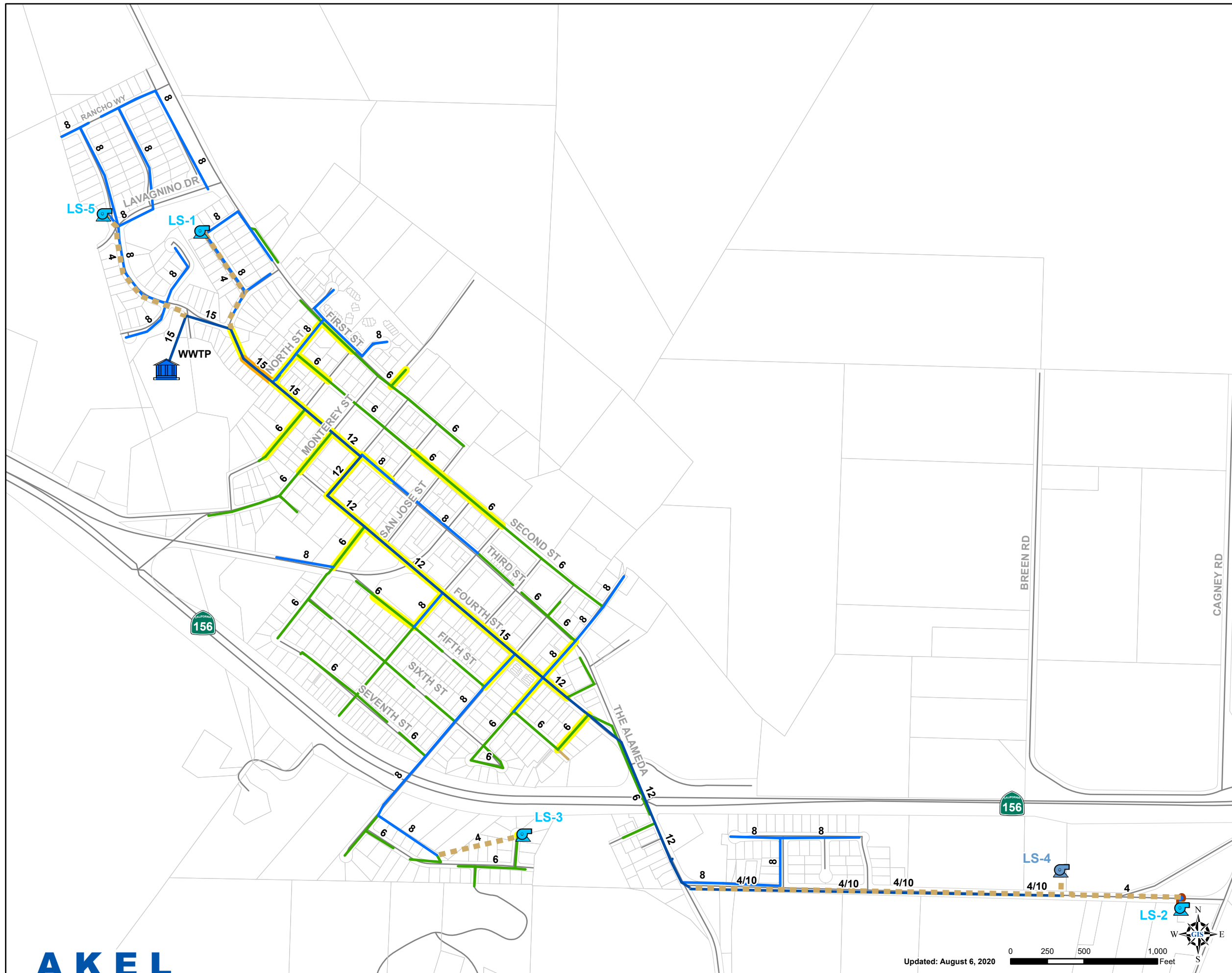

Legend

Pipe d/D

- d/D > 0.90
- d/D 0.75 - 0.90
- d/D 0.50 - 0.75

Existing System

- WWTP
- Lift Station
- Private Lift Station

Gravity Mains by Diameter

- 4"
- 6"
- 8"
- 10" and Greater

- - - Force Mains

— Streets

Parcels

Figure 7.2
Existing System Analysis
for PWWF

Wastewater Master Plan
 City of San Juan Bautista



7.2.1 Existing Peak Dry Weather Flows Capacity Evaluation

The existing dry weather flow analysis indicated several areas where pipelines, while not deficient, may be approaching full capacity. **Figure 7.1** documents pipeline d/D values under existing peak dry weather flow conditions. Deficient pipelines would be highlighted in red and were not observed under existing peak dry weather flow conditions.

7.2.2 Existing Peak Wet Weather Flows Capacity Evaluation

The wet weather flow analysis is intended to document the impact of rainfall events on the existing system, and to identify the improvements necessary to limit wastewater overflows. The design criteria for wet weather events allows pipeline surcharging in the manhole to within five feet of the rim elevation. The hydraulic analysis indicates no existing deficiencies, as shown on **Figure 7.2**. Pipeline d/D values are also highlighted to pipelines that may be approaching full capacity, ultimately leading to the potential for surcharging in the manhole within five feet of the rim elevation.

7.3 RANCHO VISTA SEWER LIFT STATION CONDITION ASSESSMENT

As part of the WWMP effort, Akel Engineering retained services of Stantec to assess the newly built Rancho Vista Sewer Lift Station's (RVSL) compliance with applicable industry standards (**Appendix B**). The major observations and findings, and recommendations found in Stantec's report are extracted from the report and included below as part of Section 7.3.

7.3.1 Major Observations and Findings

The major observations and findings of the Stantec condition assessment report are documented in the following sections:

7.3.1.1 General Site and Access

- *Good condition concrete wet well and access hatch*
- *Fencing is unsecure*
- *Poor site access*
- *Site is covered in bark and landscaping*
- *No lighting available*

7.3.1.2 Wet Well, Pumps, Valves, and other Appurtenances

- *Wet well is un-lined concrete*
- *Noted rust/corrosion on 90-degree elbow on both discharge piping in wet well*
- *Blue latex gloves in the wet well*

- *Low efficiency pumps*
- *No bypass capability or quick connection*
- *No personnel access ability into the valve vault*
- *Standing water in the valve vault*
- *No fall protection on the valve vault or the wet well*
- *Possible signs of infiltration at the concrete joints of the valve vault*
- *No SARV*

7.3.1.3 System Hydraulics

- *Sufficient firm capacity to handle current and buildout peak wet weather flow*
- *No flow meters*

7.3.1.4 Electrical

- *No alarm telemetry*
- *No backup generator*
- *No seal fittings on conduits*
- *NEMA 3R rated control panel box.*

7.3.2 Recommendations

The recommendations of the Stantec condition assessment report are documented in the following sections:

7.3.2.1 General Site and Access

- *Replace the fencing around the equipment with more secure fencing. Per industry standard, the fence should have a minimum height of 6 ft. Possible fencing options, which vary by the level of security and appearance, include a chain link fence, wrought iron fence, or a concrete masonry unit (CMU) wall. Screening can be added to the chain link fence or the wrought iron fence to further reduce visibility into the lift station site. The City and the Homeowners Association should agree on the type of fencing to ensure it is secure, while also blending with the neighborhood to the extent feasible.*
- *Provide a paved or concrete driveway from the street to the wet well and valve vault (Figure 7).*
- *Pave or construct a concrete pad around the valve vault, wet well, and control panel site, extending 5 ft from the equipment (where available) on all sides to allow for easier wash*

down and routine maintenance. The pad should slope towards the wet well for proper drainage.

- Confirm there is a water connection available for wash down and routine maintenance.
- Provide lighting for night work and safety.

7.3.2.2 Wet Well, Pumps, Valves, and other Appurtenances

- Protect the wet well and discharge pipes with corrosion resistant high solids epoxy coating system.
- Install grouted side sloped chamfers around the bottom of the wet well, as recommended by HI 9.8.
- Prevent blockages that could be caused by the blue latex gloves through direct communications with the sewer customers flushing gloves, a screening system on the wet well inlet, or a grinder pump.
- If the pumps experience mechanical issues, due to normal wear and tear of the mechanical components, replace the low efficiency pumps with high efficiency pumps, such as Flygt or ABS pumps.
- Install a quick connection/disconnect fitting to provide an ability for bypass pumping in emergency situations.
- Confirm the City has a portable crane system to remove the pumps out of the wet well.
- Install an OSHA compliant ladder in the valve vault. Use proper confined space entry equipment, such as a portable tripod system, to enter the valve vault.
- Check the invert elevations of the drain pipe between the valve vault and wet well to ensure its sloping towards the wet well.
- Check whether the drain pipe from the valve vault to the wet well is clogged and if so, unclog it.
- Install fall protection under the access hatch on the valve vault and the wet well.
- Investigate the possible signs of infiltration at the concrete joints by vacuum testing the vault.
- An SARV and pressure gauge should be connected to both discharge pipes if an SARV is not already connected at the highpoint of the force main.
- Consider possibly installing an underground overflow tank since the wet well is remote.

7.3.2.3 System Hydraulics

- Consider possibly installing a flow meter on the force main discharge pipe.

7.3.2.4 Electrical

- Install alarm telemetry so the City is alerted instantly. A cost-effective system is an auto-dialer, such as RACO AlarmAgent or similar, which could automatically call or text City personnel when an alarm occurs. A more complex system could be investigated if the City desires additional functionality, such as the ability to remotely start/stop pumps.
- Install a backup generator to reduce vulnerability.
- Install seal fittings on the conduits running from the wet well to the control panel enclosure.
- Install NEMA 4X stainless steel control panel box to protect from corrosion and outdoor environmental challenges (rain, wind, dust, etc.).

7.4 REGIONAL CONNECTION ALTERNATIVES

The City currently collects flows and conveys flows through the wastewater collection system to the City-owned wastewater treatment plant. This WWTP effluent has received repeated violation for salinity, sodium and total dissolved solids (TDS), and in more recent years, the Regional Water Quality Control Board has issued notices for high levels of biochemical oxygen demand (BOD), ammonia, and total suspended solids. As part of this master plan, various solutions to mitigate these effluent quality concerns were evaluated. These solutions would require either the upgrade of the existing WWTP or the construction of a transmission main and lift station to connect the Hollister WWTP to the existing system, as documented on [Figure 7.3](#). Stantec Consulting evaluated three treatment alternatives, which are described below and summarized in the following pages:

- **Alternative 1:** On-Site WWTP Upgrades and Off-Site Salinity Control
- **Alternative 2:** On-Site WWTP Upgrades and On-Site Salinity Control
- **Alternative 3:** Regionalization with Hollister WWTP and Off-Site Salinity Control

The preliminary engineering report evaluated the different alternatives and identified the Hollister WWTP regionalization as the preferred alternative. The following sections summarize the Preliminary Engineering Report (PER) prepared by Stantec Consulting documenting Wastewater Treatment Improvements. The PER is included in [Appendix A](#).

7.4.1 Alternative 1: On-site WWTP Upgrades and Off-Site Salinity Control

This alternative includes reducing influent salinity levels by implementing treatment solutions at the source in the form of an industrial pre-treatment program. Additionally, the removal of domestic water softening units will contribute to the reduction in salts discharged to the

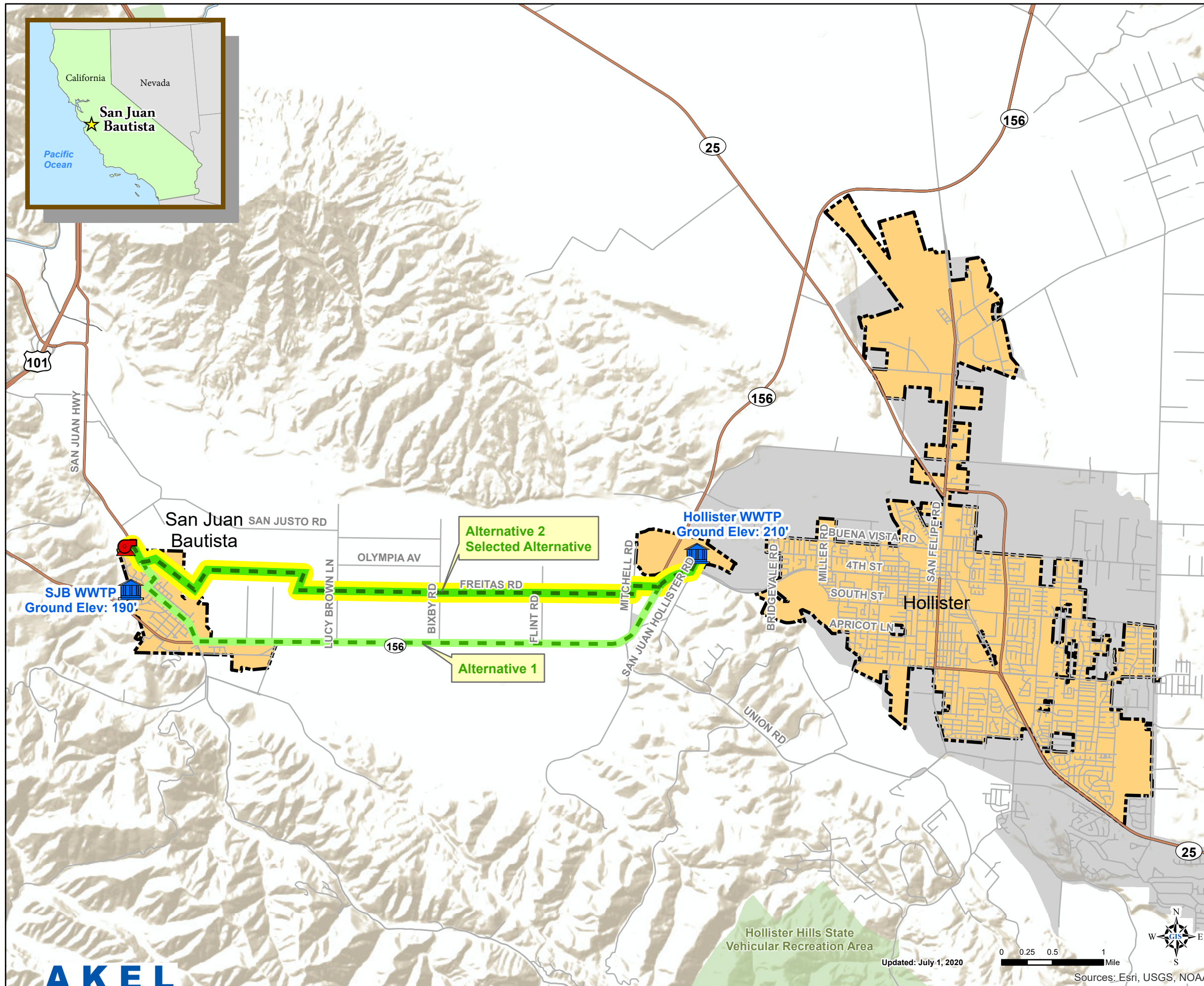

Legend

- Potential Lift Station
- Selected Connection Alignment
- Alternative Connection Alignments
- Major Highways
- City Limits
- Urbanized Area
- Protected Open Space
- Rivers/Streams
- Waterbodies

**Figure 7.3
Regional Connection
Alternatives**

Wastewater Master Plan
City of San Juan Bautista



wastewater collection system. This alternative also includes costs associated with connecting the water distribution system to the West Hills Water Treatment Plant (WTP) as a means of reducing water supply hardness.

Upgrades to the existing WWTP will also be implemented to mitigate existing treatment capacity issues and replace aging elements. The existing sequencing batch reactor (SBR) is undersized and will be replaced with a membrane bioreactor (MBR), which will ensure continued compliance with the effluent quality requirements. The total life cycle cost for this treatment alternative is \$19,418,000.

7.4.2 Alternative 2: On-site WWTP Upgrades and On-Site Salinity Control

In addition to the existing WWTP upgrades described as part of Alternative 1, this alternative also includes the installation of a reverse osmosis (RO) treatment system to reduce existing salinity levels. Based on the City's current effluent quality, only a portion of the effluent treated by the MBR would pass through the RO system. Due to the degree of salinity reduction provided by the RO system, connecting the domestic water distribution system to West Hills WTP will no longer be necessary. However, in order to maintain water supply reliability a new groundwater well will be constructed; these costs are included in the total life cycle cost of this alternative. The total life cycle cost for this treatment alternative is \$18,025,000.

7.4.3 Alternative 3: Regionalization with Hollister WWTP and Off-Site Salinity Control

This alternative includes the decommissioning of the City's WWTP and the conveyance of all collected wastewater to the City of Hollister's WWTP. The City's existing WWTP ponds will be converted into equalization and emergency storage basin. The salinity levels of the City's collected wastewater effluent must be within the City of Hollister's limits. Therefore, similar to Alternative 1, off-site salinity control will be enacted in the form of an industrial pre-treatment program and connection of the City's domestic water system to the West Hills WTP. The total life cycle cost for this treatment alternative is \$25,253,000.

The proposed transmission main and lift station, as summarized on [Table 7.1](#) and graphically shown on [Figure 7.4](#), are described as follows.

- **P-4:** Construct approximately 33,700 feet of new 8-inch sewer force main along 1st Street and future Right-of-Way north of Highway 156, from north of Rancho Way to the Hollister WWTP. This improvement will cost approximately \$7,216,000.
- **FLS-6:** Construct a new lift station north of Rancho Way and Vista Way. This lift station will include 4 pumps with a capacity of 520 gpm each, three duty and one standby, for a total capacity of 2,080 gpm. This improvement will cost approximately \$2,268,000.

7.4.4 Preferred Wastewater Treatment Improvement Alternative

The PER used a scoring matrix to evaluate the multiple wastewater treatment improvement alternatives. The criteria included in the matrix were as follows: life cycle costs, footprint, ease of

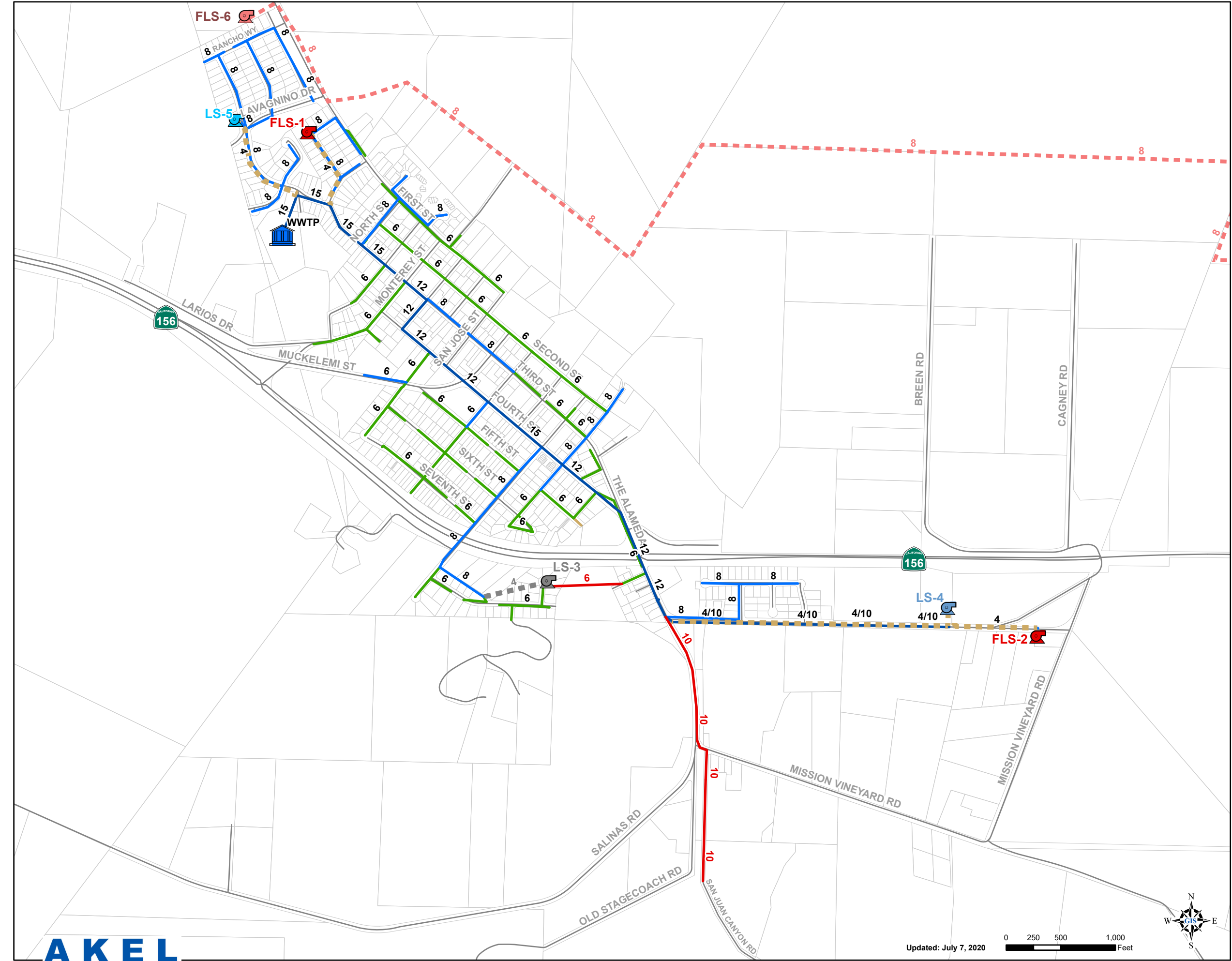

Legend

- Future Lift Station
- Hollister WWTP Connection Pump
- Abandoned Lift Station
- Future Pipes
- Hollister WWTP Connection Force Main
- Abandoned Force Main

Existing System

- WWTP
- Lift Station
- Private Lift Station

Gravity Mains by Diameter

- 4"
- 6"
- 8"
- 10" and Greater

Force Mains

- Force Mains

Streets and Parcels

- Streets
- Parcels

Figure 7.4
Recommended Improvements
 Wastewater Master Plan
 City of San Juan Bautista



Table 7.1 Schedule of Improvements
Wastewater Master Plan
City of San Juan Bautista

Improv. No.	Type of Improvement	Alignment	Limits	Existing Diameter (in)	Pipeline Improvements		
					New/Parallel/ Replace	Diameter (in)	Length (ft)
Pipeline Improvements							
P-1	Gravity Main	San Juan Canyon Rd	From 1,200 s/o Mission Vineyard Rd to Mission Vineyard Rd	-	New	10	1,200
P-2	Gravity Main	Monterey and Alameda State Hwy	From Mission Vineyard Rd to Old San Juan Hollister Rd	-	New	10	1,350
P-3	Gravity Main	ROW	From Lang Ct. Cul-de-sac to Lang St.	-	New	6	720
P-4	Force Main	Along 1st St and Future ROW north of Hwy 156	From north of Rancho Wy to Hollister WWTP	-	New	8	33,700
P-5	Casing	ROW	Crossing under Hwy 156	-	New	28	160
Lift Station Improvements							
FLS-1	Lift Station Replacement	Lift Station 1 (SJB WWTP)			Replace	3 @ 25 gpm	
FLS-2	Lift Station Replacement	Lift Station 2 (Old San Juan Hollister Rd & Mission Vineyard Rd)			Replace	2 @ 180 gpm	
FLS-6	New Lift Station	Approximately 200 ft n/o intersection of Rancho Wy and Vista Wy (SJB to Hollister WWTP)			New	4 @ 520 gpm	

operation and maintenance, reliability, and flexibility with future regulations. Based on the criteria evaluated the recommended wastewater treatment improvement alternative is Alternative 3, Regionalization with Hollister WWRP and Off-Site Salinity Control.

7.5 ULTIMATE BUILDOUT CAPACITY IMPROVEMENTS

The system performance and design criteria summarized on [Table 3.1](#), was used as a basis to evaluate the capacity adequacy of the existing wastewater collection system. The design flows simulated in the hydraulic model for the General Plan buildout were summarized on [Table 5.3](#) and are documented as follows:

- Buildout PDWF = 1.39 mgd
- Buildout PWWF = 2.25 mgd

Wastewater collection system pipelines are recommended to serve future growth inside the City and increase the reliability of the wastewater collection system as well. The proposed capacity improvements for the wastewater collection system are listed on [Table 7.1](#). This table lists the master plan assigned improvement number (e.g., P-1), along with other relevant information including alignment description, pipe size, and pipe length. The improvement number is further defined in the Capital Improvement Program chapter (Chapter 8). The improvements are described in detail on the following sections and shown on [Figure 7.4](#).

7.5.1 Recommended Pipeline Improvements

This section documents pipeline improvements for the San Juan Bautista wastewater collection system.

- **P-1:** Construct a new 10-inch gravity main in San Juan Canyon Road from 1,200 feet south of Mission Vineyard Road to Mission Vineyard Road to capture wastewater flows from existing septic users and future buildout users in the south-east portion of the service area.
- **P-2:** Construct a new 10-inch gravity main along Monterey and Alameda State Highway from Mission Vineyard Road to Old San Juan Hollister Road to capture wastewater flows from existing septic users and future buildout users in the south-east portion of the service area.
- **P-3:** Construct a new 6-inch gravity main along right-of-way from Lang Court cul-de-sac to Lang Street. It should be noted that this improvement is required to convey flows tributary to Lift Station 3 (Lang Court cul-de-sac) due to the lift station failing and the City's decision to abandon the existing lift station. New pipeline will convey existing wastewater flows to the existing gravity main along The Alameda.

7.5.2 Recommended Lift Station Improvements

This section documents lift station improvements for the San Juan Bautista wastewater collection system. Lift station improvements were determined by completing an existing lift station capacity analysis comparing peak flows to existing pumping capacity to lift station firm capacity which assumes one standby pump ([Table 7.2](#)).

- **FLS-1:** Replace the 3 existing 20 gpm pumps at Lift Station 1 (SJB WWTP) with 3 new pumps rated at 25 gpm each.
- **FLS-2:** Replace the 2 existing 100 gpm pumps at Lift Station 2 (Old San Juan Hollister Road and Mission Vineyard Road) with 2 new pumps rated at 180 gpm each.

Table 7.2 Existing Lift Station and Capacity Analysis

Wastewater Master Plan

City of San Juan Bautista

Pump Station No.	Facility Name	Firm Capacity (Excludes Standby) (gpm)	Total Capacity (Includes Standby) (gpm)	Existing Peak Flows				Buildout Flows				Surplus/Deficiency (gpm)	Adequate Capacity	Recommended Total Pump Station Capacity (gpm)
				Dry Weather		Wet Weather		Dry Weather		Wet Weather				
				(gpm)	(mgd)	(gpm)	(mgd)	(gpm)	(mgd)	(gpm)	(mgd)			
LS-1	(SJB WWTP)	40	60	22.4	0.032	47.9	0.069	23.1	0.033	49.3	0.071	-9.3	No	3 @ 25 gpm
LS-2 ¹	(Old San Juan Hollister Rd & Mission Vineyard Rd)	100	200	0.0	0.000	133.6	0.192	76.5	0.110	177.9	0.256	-77.9	No	2 @ 180 gpm
LS-3 ²	(Lang Ct. Cul-de-sac)	67	134	8.5	0.012	17.6	0.025	Lift Station to be Abandoned				-	-	-
LS-5	(Rancho Vista Lift Station)	100	200	3.4	0.005	77.1	0.111	26.6	0.038	90.1	0.130	9.9	Yes	



8/6/2020

Notes:

1. There are no existing users tributary to Lift Station 2 that contribute Dry Weather Flow. Wet Weather flow is based on Rainfall Dependent Infiltration and Inflow for the area tributary to the Lift Station.
2. Lift Station 3 to be abandoned per City comments.

CHAPTER 8 - CAPITAL IMPROVEMENT PROGRAM

This chapter provides a summary of the recommended wastewater collection system improvements to mitigate existing capacity deficiencies and service future growth. This chapter also presents the cost criteria and methodologies for developing the capacity improvement costs. Finally, a capacity allocation analysis, usually used for cost sharing purposes, is also included.

8.1 COST ESTIMATE ACCUARCY

Cost estimates presented in the CIP were prepared for general master planning purposes and, where relevant, for further project evaluation. Final costs of a project will depend on several factors including the final project scope, costs of labor and material, and market conditions during construction.

The Association for the Advancement of Cost Engineering (AACE International), formerly known as the American Association of Cost Engineers, has defined three classifications of assessing project costs. These classifications are presented in order of increasing accuracy: Order of Magnitude, Budget, and Definitive.

- **Order of Magnitude Estimate.** This classification is also known as an “original estimate”, “study estimate”, or “preliminary estimate”, and is generally intended for master plans and studies.

This estimate is not supported with detailed engineering data about the specific project, and its accuracy is dependent on historical data and cost indices. It is generally expected that this estimate would be accurate within -30 percent to +50 percent.

- **Budget Estimate.** This classification is also known as an “official estimate” and generally intended for pre-design studies. This estimate is prepared to include flow sheets and equipment layouts and details. It is generally expected that this estimate would be accurate within -15 percent to +30 percent.
- **Definitive Estimate.** This classification is also known as a “final estimate” and prepared during the time of contract bidding. The data includes complete plot plans and elevations, and equipment data sheets, and complete specifications. It is generally expected that this estimate would be accurate within -5 percent to +15 percent.

Costs developed in this study should be considered “Order of Magnitude” and have an expected accuracy range of **-30 percent** and **+50 percent**.

8.2 COST ESTIMATE METHODOLOGY

Cost estimates presented in this chapter are opinions of probable construction and other relevant costs developed from several sources including cost curves, Akel experience on other master planning projects, and input from City staff on the development of public and private cost sharing. Where appropriate, costs were escalated to reflect the more current Engineering News Records (ENR) Construction Cost Index (CCI).

This section documents the unit costs used in developing the opinion of probable construction costs, the Construction Cost Index, the land acquisition costs, and markups to account for construction contingency and other project related costs.

8.2.1 Unit Costs

The unit cost estimates used in developing the Capital Improvement Program are summarized on [Table 8.1](#). Wastewater pipeline unit costs are based on length of pipe per chosen diameter. Lift station costs are based on capacity, per million gallons per day (MGD).

The unit costs are intended for developing the Order of Magnitude estimate, and do not account for site specific conditions, labor or material costs during the time of construction, final project scope, implementation schedule, detailed utility and topography surveys, investigation of alternative routings for pipes, and other various factors. The capital improvement program included in this report accounts for construction and project-related contingencies as described in this chapter.

8.2.2 Construction Cost Index

Costs estimated in this study are adjusted utilizing the Engineering News Record (ENR) Construction Cost Index (CCI), which is widely used in the engineering and construction industries.

The costs in this Wastewater Master Plan were benchmarked using a 20-City national average ENR CCI of 11,412, reflecting a date of April 2020.

8.2.3 Land Acquisition

Construction of pipelines is assumed to generally be within existing or future street right-of-ways. Lift station's land acquisition costs are included in the lift station unit cost.

8.2.4 Construction Contingency Allowance

Knowledge about site-specific conditions for each proposed project is limited at the master planning stage; therefore, construction contingencies were used. The estimated construction costs in this master plan include a **30 percent** contingency allowance to account for unforeseen events and unknown field conditions.

Table 8.1 Unit Costs

Wastewater Master Plan
City of San Juan Bautista

Pipelines	
Pipe Size (in)	Cost (\$/lineal foot)
6	168
8	225
10	250
12	287
15	312
18	337
21	362
24	412
27	463
30	515
36	618
8 (Force Main)	149

Lift Station
Estimated Lift Station Project Cost = $9,308*Q^2 + 302,513*Q + 352,230$, where Q is in mgd

AKEL
ENGINEERING GROUP, INC.

8/6/2020

Notes :

1. Construction costs estimated using April 2020 ENR CCI of 11,412.

8.2.5 Project Related Costs

The capital improvement costs also account for project-related costs, comprising of engineering design, project administration (developer and City staff), construction management and inspection, and legal costs. The project related costs in this master plan were estimated by applying an additional **30 percent** to the estimated construction costs.

8.3 CAPITAL IMPROVEMENT PROGRAM

This section documents the capital improvement program, contingencies included in the costs, and the allocation of costs to meet the requirements of AB1600.

8.3.1 Capital Improvement Costs

The Capital Improvement Program costs for the projects identified in this master plan for mitigating existing deficiencies and for servicing anticipated future growth throughout the City are summarized on **Table 8.2**.

Each improvement was assigned a unique coded identifier associated with the improvement type and is summarized graphically on **Figure 8.1**. The estimated construction costs include the baseline costs plus **30 percent** contingency allowance to account for unforeseen events and unknown field conditions, as described in a previous section. Capital improvement costs include the estimated construction costs plus **30 percent** project-related costs (engineering design, project administration, construction management and inspection, and legal costs).

8.3.2 Regional Connection Alternatives

The Capital Improvement Program costs include costs for the regional connection alternative, as identified in the preliminary engineering report (PER) assembled by Stantec Engineering. It should be noted that these costs include baseline infrastructure costs, as well as the aforementioned construction and capital improvement contingency costs. The final costs for each alternative, including costs related to O&M can be found in the PER in **Appendix A**.

8.3.3 Recommended Cost Allocation Analysis

Cost allocation analysis is needed to identify improvement funding sources, and to establish a nexus between development impact fees and improvements needed to service growth. In compliance with the provisions of Assembly Bill AB 1600, the analysis differentiates between the project needs of servicing existing users and for those required to service anticipated future developments. The cost responsibility is based on model parameters for existing and future land use, and may change depending on the nature of development. **Table 8.2** lists each improvement, and separates the cost by responsibility between existing and future users.

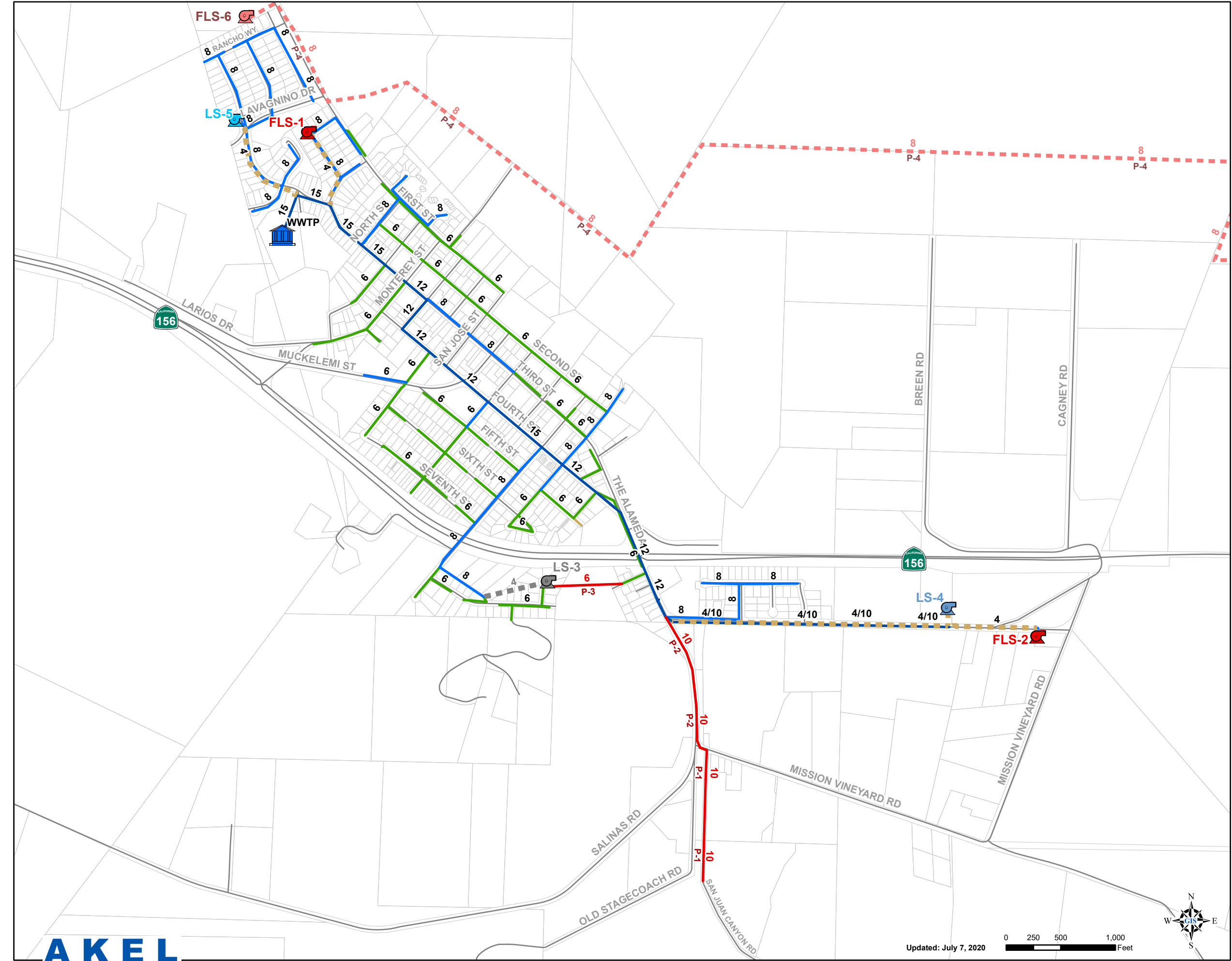

Legend

- Future Lift Station
- Hollister WWTP Connection Pump
- Abandoned Lift Station
- Future Pipes
- Hollister WWTP Connection Force Main
- Abandoned Force Main

Existing System

- WWTP
- Lift Station
- Private Lift Station

Gravity Mains by Diameter

- 4"
- 6"
- 8"
- 10" and Greater

- Force Mains
- Streets
- Parcels

Figure 8.1
Capital Improvement Program
 Wastewater Master Plan
 City of San Juan Bautista



Table 8.2 Buildout Capital Improvement Program

Wastewater Master Plan
City of San Juan Bautista

Improv. No.	Type of Improvement	Alignment	Limits	Improvement Details				Infrastructure Costs		Baseline Construction Cost	Estimated Construction Cost ²	Capital Improvement Cost ³	Construction Trigger	Suggested Cost Allocation		Cost Allocation	
								Unit Cost	Infr. Cost ¹					Existing Users	Future Users	Existing Users	Future Users
								(\$)	(\$)	(\$)	(\$)	(\$)	(%)	(%)	(\$)	(\$)	
Pipeline Improvements				Existing Diameter	New/Replace	Diameter	Length										
				(in)		(in)	(ft)										
P-1	Gravity Main	San Juan Canyon Rd	From 1,200 s/o Mission Vineyard Rd to Mission Vineyard Rd	-	New	10	1,200	250	300,000	300,000	390,000	507,000	With Development	0%	100%	0	507,000
P-2	Gravity Main	Monterey and Alameda State Hwy	From Mission Vineyard Rd to Old San Juan Hollister Rd	-	New	10	1,350	250	337,500	337,500	438,800	570,500	With Development	0%	100%	0	570,500
P-3	Gravity Main	ROW	From Lang Ct. Cul-de-sac to Lang St.	-	New	6	720	168	120,960	121,000	157,300	204,500	Existing Deficiency	100%	0%	204,500	0
P-4	Force Main	Along 1st St and Future ROW north of Hwy 156	From north of Rancho Wy to Hollister WWTP	-	New	8	33,700	149	4,155,990	4,156,000	5,402,800	7,023,700	Existing Deficiency	37%	63%	2,584,021	4,439,679
P-5	Casing	ROW	Crossing under Hwy 156	-	New	28	160	709	113,514	113,600	147,700	192,100	Existing Deficiency	37%	63%	70,674	121,426
								Subtotal - Pipeline Improvements		5,027,963	5,028,100	6,536,600	8,497,800			2,859,194	5,638,606
Lift Station Improvements				Existing Capacity	New/Replace	Capacity											
				(gpm)		(gpm)											
FLS-1	Lift Station Replacement	Lift Station 1 (SJB WWTP)		3 @ 20 gpm	Replace	3 @ 25 gpm			385,010	385,100	500,700	651,000	Existing Deficiency	97%	3%	632,397	18,603
FLS-2	Lift Station Replacement	Lift Station 2 (Old San Juan Hollister Rd & Mission Vineyard Rd)		2 @ 100 gpm	Replace	2 @ 180 gpm			511,554	511,600	665,100	864,700	With Development	0%	100%	0	864,700
FLS-6	New Lift Station	Approximately 200 ft n/o intersection of Rancho Wy and Vista Wy (SJB to Hollister WWTP)		-	New	4 @ 520 gpm			1,341,821	1,341,900	1,744,500	2,267,900	Existing Deficiency	37%	63%	834,361	1,433,539
								Subtotal - Lift Station Improvements		2,238,385	2,238,600	2,910,300	3,783,600			1,466,758	2,316,842
Total Wastewater System Improvements																	
								Subtotal Pipeline Improvements		5,027,963	5,028,100	6,536,600	8,497,800			2,859,194	5,638,606
								Subtotal Lift Station improvements		2,238,385	2,238,600	2,910,300	3,783,600			1,466,758	2,316,842
								Total Improvement Costs		7,266,349	7,266,700	9,446,900	12,281,400			4,325,952	7,955,448



Notes:

1. Portions of the alignment of the pipeline P-4 exist in agricultural land with no paving, thus pipeline unit costs were reduced by 30% to account for the following: 25% reduction for pavement replacement, and 5% reduction for traffic control.
2. Baseline construction costs plus 30% to account for unforeseen events and unknown conditions.
3. Estimated construction costs plus 30% to cover other costs including: engineering design, project administration (developer and City staff), construction management and inspection, and legal costs.

8.3.4 Construction Triggers

As a part of this master planning process construction triggers were developed in an effort to plan the expansion of the water system in an orderly manner. The construction triggers for multiple improvements are based on mitigating an existing system deficiency, increasing hydraulic reliability, or continuing improvements currently planned by the City. Other improvements replace existing infrastructure that is not currently deficient but will violate master plan criteria with future development. The construction triggers quantify the amount of additional development that may occur before the improvement becomes necessary.

APPENDICES

APPENDIX A

Wastewater Treatment Improvements Plan



**San Juan Bautista, Wastewater
Treatment Improvements Project**

Preliminary Engineering Report

September 28, 2020

Submitted to:

Akel Engineering Group, Inc.

Prepared for:

The City of San Juan Bautista

Prepared by:

Stantec Consulting Services Inc.



SAN JUAN BAUTISTA, WASTEWATER TREATMENT IMPROVEMENTS PROJECT

This document entitled San Juan Bautista, Wastewater Treatment Improvements Project Preliminary Engineering Report was prepared by Stantec Consulting Services Inc. ("Stantec") for the account of City of San Juan Bautista (the "Client"). Any reliance on this document by any third party is strictly prohibited. The material in it reflects Stantec's professional judgment in light of the scope, schedule and other limitations stated in the document and in the contract between Stantec and the Client. The opinions in the document are based on conditions and information existing at the time the document was published and do not take into account any subsequent changes. In preparing the document, Stantec did not verify information supplied to it by others. Any use which a third party makes of this document is the responsibility of such third party. Such third party agrees that Stantec shall not be responsible for costs or damages of any kind, if any, suffered by it or any other third party as a result of decisions made or actions taken based on this document.

Prepared by 
(signature)
Beth Cohen, P.E.

Reviewed by 
(signature)
Steven L. Beck, P.E.



Table of Contents

INTRODUCTION	1
1.0 PROJECT PLANNING	2
1.1 LOCATION	2
1.2 ENVIRONMENTAL RESOURCES PRESENT	3
1.2.1 Engineered Environmental Mitigation	5
1.3 POPULATION TRENDS	5
1.4 COMMUNITY ENGAGEMENT	6
2.0 EXISTING WWTP FACILITIES	6
2.1 LOCATION MAP	7
2.2 HISTORY	8
2.2.1 Flows and Load Characterization	8
2.3 CONDITION OF EXISTING FACILITIES	19
2.3.1 Process Descriptions and Summary of Condition	19
2.3.2 Discharge Permit Compliance Issues	21
2.4 FINANCIAL STATUS OF EXISTING FACILITIES	24
2.5 WASTEWATER AUDITS	25
2.5.1 WWTP Influent Salinity Balance	25
3.0 NEED FOR PROJECT	29
3.1 HEALTH, SANITATION, AND SECURITY	29
3.1.1 Biological and Solids Management Project Needs	29
3.1.2 Tertiary Treatment and Disinfection Project Needs	29
3.1.3 Salinity Control Project Needs	30
3.2 AGING INFRASTRUCTURE	31
3.3 REASONABLE GROWTH	31
4.0 WWTP UPGRADE ALTERNATIVES CONSIDERED	32
4.1 ALTERNATIVE DESCRIPTIONS AND COST ESTIMATES	34
4.1.1 Alternative 1, On-Site WWTP Upgrades and Off-Site Salinity Control	34
4.1.2 Alternative 2, On-Site WWTP Upgrades and On-Site Salinity Control	39
4.1.3 Alternative 3, Off-Site Salinity Source Control and Regionalization with Hollister WWTP	44
4.2 COMMON DESIGN CRITERIA	47
4.3 POTENTIAL ENVIRONMENTAL IMPACTS OF PROJECT ALTERNATIVES	50
4.3.1 Alternative 1, On-Site WWTP Upgrades and Off-Site Salinity Control	50
4.3.2 Alternative 2, On-Site WWTP Upgrades and On-Site Salinity Control	50
4.3.3 Alternative 3, Off-Site Salinity Source Control and Regionalization with Hollister WWTP	50
4.4 LAND REQUIREMENTS	50
4.5 POTENTIAL CONSTRUCTION PROBLEMS	50
4.6 SUSTAINABILITY CONSIDERATIONS	51
4.6.1 Water and Energy Efficiency	51

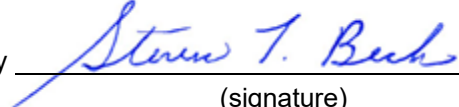

4.6.2	Other, California Priorities	51
4.7	COST ESTIMATES.....	52
5.0	SELECTION OF AN ALTERNATIVE	52
5.1	LIFE CYCLE COST ANALYSIS	52
5.2	NON-MONETARY FACTORS.....	54
6.0	PROPOSED PROJECT, RECOMMENDED ALTERNATIVE.....	57
6.1	PRELIMINARY PROJECT DESIGN DESCRIPTION.....	57
6.2	PROPOSED PROJECT SCHEDULE	57
6.3	PERMIT REQUIREMENTS.....	58
6.4	SUSTAINABILITY CONSIDERATIONS.....	59
6.5	ENGINEER’S OPINION OF PROBABLE COSTS	60
6.6	ANNUAL OPERATING BUDGET	61
6.6.1	Income.....	61
6.6.2	Annual O&M Costs	61
6.6.3	Debt Repayments.....	62
6.6.4	Reserves	62
7.0	CONCLUSION AND RECOMMENDATIONS.....	63

LIST OF TABLES

Table 1	San Juan Bautista Population Data	6
Table 2	Relationship Between ADWF and AAF.....	10
Table 3	Source Water Chemistry for Existing City Wells	16
Table 4	Industrial Drain Sampling Data	17
Table 5	WWTP Design Flows and Loads	18
Table 6	Existing WWTP Design Criteria	19
Table 7	Financial Status, 2019 Auditor’s Report.....	24
Table 8	WWTP Influent Salinity Balance (Average Daily Loads).....	26
Table 9	West Hills WTP Life Cycle Costs	34
Table 10	MBR Design Criteria	37
Table 11	MBR Process Life Cycle Costs	38
Table 12	Alternative 1 Life Cycle Costs	38
Table 13	Reverse Osmosis Design Criteria.....	42
Table 14	Alternative 2 Life Cycle Costs	43
Table 15	Regionalization Design Criteria.....	44
Table 16	Alternative 3 Life Cycle Costs	47
Table 17	WWTP Improvement Project Design Criteria.....	49
Table 18	Alternative Options Life Cycle Costs Summary	53
Table 19	Improvements Project Selection Criteria.....	54
Table 20	Improvements Project Options Criteria Weight.....	55
Table 21	Improvements Project Options Selection Matrix	56
Table 22	Preliminary Project Schedule	57
Table 23	Future WWTP Influent Salinity Balance (Average Daily Loads)	59
Table 24	Total Project Cost Estimate	60
Table 25	Projected Operations and Maintenance Costs	61



Table 26 Statement of Net Asset Positions 62

LIST OF FIGURES

Figure 1 San Juan Bautista WWTP Vicinity Map 3
 Figure 2 San Juan Bautista WWTP Site Layout 7
 Figure 3 WWTP Historical Influent Flow Rates 8
 Figure 4 Flow Peaking Factors (Ratio of Daily and Monthly Flow to AAF) 9
 Figure 5 Influent BOD & TSS Loading 10
 Figure 6 Influent TSS to BOD Ratio 11
 Figure 7 BOD and TSS Peaking Factors (Ratio of ADMML/AAL)..... 12
 Figure 8 Influent TDS Loading 13
 Figure 9 Influent Sodium and Chloride Loading 14
 Figure 10 Influent TDS Concentration 14
 Figure 11 Influent Sodium and Chloride Concentrations 15
 Figure 12 Partition Wall Between Sludge Storage Lagoon and Polishing Pond 20
 Figure 13 Effluent Monthly Salinity Concentrations 21
 Figure 14 BOD and TSS Effluent Concentrations 22
 Figure 15 Daily Total Coliform Effluent Concentrations 23
 Figure 16 Five-Day Median Total Coliform Effluent Concentrations 23
 Figure 17 – Salinity Sources, Salt Balance 27
 Figure 18 – Alternative 1, MBR Treatment Process Flow Schematic 36
 Figure 19 – Alternative 2, MBR/RO Treatment Process Flow Schematic 40
 Figure 22 – Spiral-Wound RO Membrane Element Diagram 41
 Figure 21 – Potential Regional Pipeline Alignment 45

LIST OF APPENDICES

APPENDIX A: 2020 WATER AND WASTEWATER MASTER PLAN
 APPENDIX A.1: SOURCE AND POTABLE WATER IMPROVEMENTS PROJECT
 APPENDIX B: CURRENT CITY BUDGET AND FINANCIAL AUDITS
 APPENDIX C: VIOLATION NOTICES AND REGIONAL BOARD COMMUNICATIONS
 APPENDIX D: PELLET PLANT REPORT



INTRODUCTION

The San Juan Bautista Wastewater Treatment Plant (WWTP) operates under Order No. R3-2009-0019 NPDES permit No. CA0047902. Amongst other effluent limitations, the average monthly discharge limits for chloride, sodium, and total dissolved solids (TDS) are 200 mg/L, 250 mg/L, and 1400 mg/L, respectively. The City has been in violation of these three effluent limits for several years and currently remains in violation.

The elevated chloride, sodium, and TDS levels observed in the City's wastewater are thought to be driven by agricultural processing (disinfection chemicals) and source water (groundwater) hardness and associated self-regenerating water softeners used for potable water treatment throughout the community. The agricultural processing facilities discharge can be mitigated by establishing a new industrial pre-treatment program, but source water reductions may still be necessary. The existing groundwater wells produce very hard water (greater than 300 mg/L as CaCO₃) and, as a result, many of the City's residents have installed domestic self-regenerating water softeners to provide local treatment. Water softeners exchange calcium and magnesium (the main constituents contributing to hardness) for sodium or common salt (sodium chloride, NaCl). This process results in elevated chloride, sodium, and TDS concentrations that are discharged into the City's wastewater collection system and then pass through the WWTP untreated, causing effluent discharge permit violations.

The purpose of this report is to investigate alternatives and develop a recommended program to bring the wastewater treatment plant into compliance with regulatory requirements. The alternative projects considered herein include the following:

1. Alternative 1, On-Site WWTP Upgrades and Off-Site Salinity Control: Provide source control in order to reduce the wastewater influent salinity concentrations to permissible levels. This project will allow the existing WWTP to remain operational with upgrades to the existing process facilities. All off-site salinity control options will also include the implementation of an industrial pre-treatment program for agricultural processing facilities (to limit salt discharge from those users).
 - A. Off-site salinity control will be accomplished by replacing well water (very hard water) with treated surface water (moderately hard) and remove self-regenerating water softeners in order to reduce the wastewater influent salinity concentrations to permissible levels (as detailed in Appendix A.1).
2. Alternative 2, On-Site WWTP Upgrades and On-Site Salinity Control: This project will replace the existing WWTP sequencing batch reactor (SBR) treatment system with a new membrane bioreactor (MBR), and reverse osmosis (RO) treatment or Electrodialysis Reversal (EDR) facilities that will remove salinity.



3. Alternative 3, Regionalization with Hollister WWTP and Off-Site Salinity Control: Provide source control in order to reduce the wastewater influent salinity concentrations and then pump the influent wastewater to a neighboring community (the City of Hollister WWTP). This project will replace the existing WWTP with an equalization basin and emergency storage pond to service a new pump station and pipeline to the Hollister WWTP for off-site treatment and disposal. All off-site salinity control options will also include the implementation of an industrial pre-treatment program for agricultural processing facilities (to limit salt discharge from those users).
 - A. Off-site salinity control will be accomplished by replacing well water (very hard water) with treated surface water (moderately hard) and remove self-regenerating water softeners in order to reduce the wastewater influent salinity concentrations to permissible levels (as detailed in Appendix A.1).

Alternatives 1 and 3 both require agricultural processing facilities to have an industrial pre-treatment program (reducing the allowable salinity discharge into the sewers) and potable water source control in order to reduce wastewater influent salinity concentrations to permissible levels (i.e. providing soft water to the community and eliminating self-regenerating water softeners that dump high levels of chloride, sodium, and TDS into the sewers). The source control options were investigated in a separate report (see Appendix A.1) that will be considered herein for its life cycle costs and impacts on the associated alternative.

This Preliminary Engineering Report documents the alternative analysis and provides additional information related to the Best Apparent Project with the intent of complying with the requirements of the United States Department of Agriculture – Rural Development (USDA-RD) funding program.

1.0 PROJECT PLANNING

The purpose of this section is to describe the project area, including the location, environmental resources, population and community. This section is divided into the following sub sections.

- Project Location
- Environmental Resources Present
- Population Trends
- Community Engagement

1.1 LOCATION

The City of San Juan Bautista (City) provides sanitary sewer collection, treatment and disposal for the community and is located in San Benito County, California. The Wastewater Treatment Plant (WWTP) is located on APN 002-220-0070 at 1120 Third Street, San Juan Bautista, CA 95045. A vicinity map showing the location of the WWTP is shown in **Figure 1**.



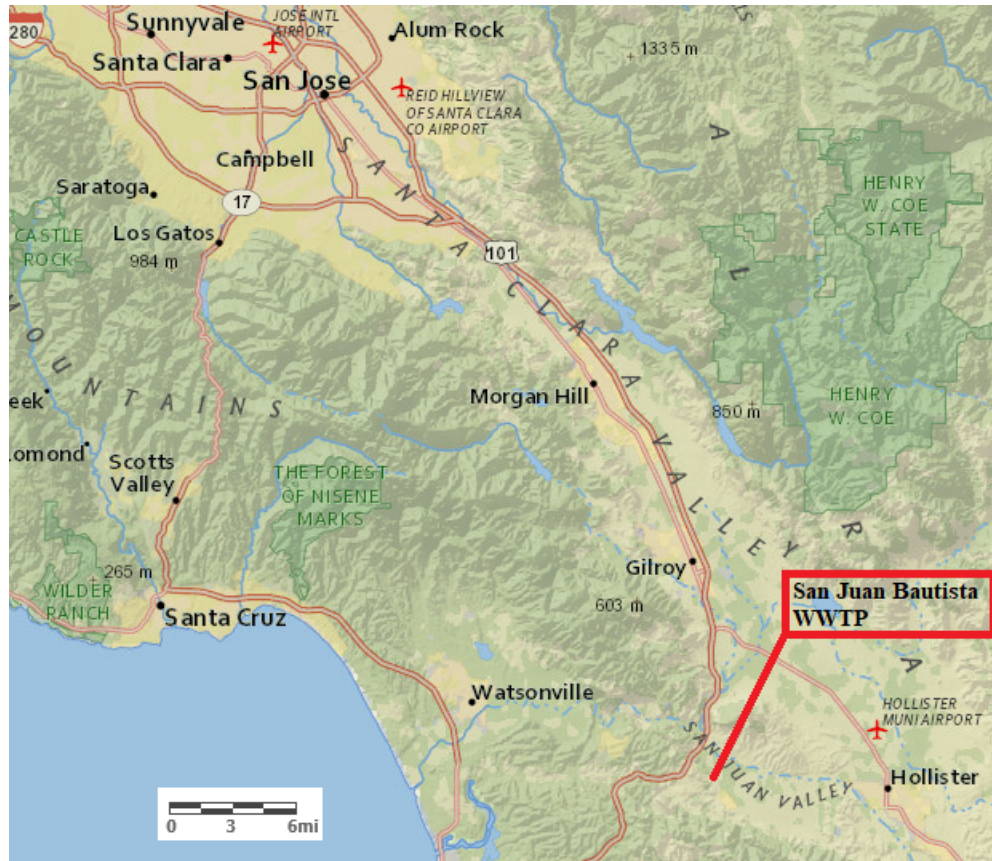

Figure 1 San Juan Bautista WWTP Vicinity Map

1.2 ENVIRONMENTAL RESOURCES PRESENT

A separate CEQA Initial Study and Mitigated Negative Declaration (IS/MND) checklist will be provided to document environmental resources present in the Project area and impacts from this Project are generally anticipated to be as follows:

- **Aesthetics.** Less than significant with mitigation incorporated. The selected project is considered to have less than significant impact.
- **Agricultural Resources.** No Impact. The selected project is not anticipated to impact any existing farmland (as the entire project falls under the rehabilitation of existing facilities and regional pipeline alignments along existing roads within the public-right-of-way) and could be used to improve those resources by providing high quality effluent discharged to downstream agricultural resources.



SAN JUAN BAUTISTA, WASTEWATER TREATMENT IMPROVEMENTS PROJECT

- **Air Quality.** Less than significant with mitigation incorporated. The selected project will have a similar amount of equipment as the existing facilities, with the opportunity to provide more efficient motors and control algorithms within the rehabilitated facility.
- **Biological Resources.** No Impact. The selected project does not have any impacts to known habitat as it involves replacing existing infrastructure. However, habitat is known to exist in the project vicinity and will require careful biological surveys.
- **Cultural Resources.** No Impact. The site has been extensively modified and no archeological or historic resources were noted during the construction and operation of the facility. Further, if human remains are unearthed during construction, the project will be halted until a qualified archeologist can assess its significance and until the County Coroner has made necessary findings as to the origin.
- **Geology and Soils.** Less Than Significant Impact. The selected project is expected to have an equal or lesser risk related to expansive soils.
- **Hazardous Material.** Less than significant. The selected project does not anticipate encountering any hazardous materials and all process chemicals will be double contained.
- **Hydrology and Water Quality.** No Impact. The selected project is anticipated to have a positive impact on water quality.
- **Land Use and Planning.** No Impact. The selected project would not change or alter any existing land use planning.
- **Mineral Resources.** No Impact. The selected project is not anticipated to impact mineral resources.
- **Noise.** No Impact. The selected project is not anticipated to create more noise than the existing wastewater facility and, in fact, will have modern drives and controllers that reduce noise from potential receptors.
- **Population and Housing.** No Impact. The selected project will serve the same community plan and have a positive impact on the surrounding community by providing reliable wastewater treatment.
- **Public Services.** No Impact. The selected project will not impact public services.
- **Recreation.** No Impact. The selected project will not impact recreation opportunities in the community.
- **Transportation/Traffic.** No Impact. The selected project will not impact traffic except during construction, but there will be no long-term transportation or traffic impacts.
- **Utilities or Services.** No Impact. The selected project will not impact utilities except to repair and rehabilitate the City of San Juan Bautista WWTP.



1.2.1 Engineered Environmental Mitigation

The proposed Project is located within the existing WWTP fence line (and potentially a regional pipeline along road alignments within the public right-of-way), in previously disturbed areas and the nearest neighbors are over 200 feet away. As such, the Project does not have the potential to degrade the quality of the environment, substantially reduce the habitat of a fish or wildlife species, cause a fish or wildlife population to drop below self-sustaining levels, threaten to eliminate a plant or animal community or reduce the number or restrict the range of a rare or endangered plant or animal. The amount of disturbance within the Project area (existing WWTP and roadways) indicates a low likelihood that cultural resources would be encountered during Project construction activities. Therefore, the potential array of impacts is considered less than significant and assumed to require the following Best Management Practices (to be verified in the IS/MND):

Erosion Control and Stormwater Pollution Prevention Plan: The construction contractor will prepare an erosion control plan and a stormwater pollution prevention plan prior to construction for all grading activities that exceed one acre of disturbance (as required by the Regional Board). The plans shall provide, at a minimum, measures to trap sediment, stabilize excavated soil piles, stabilize and revegetate disturbed areas, and any special stabilization measures required by the design engineer or the City. The plan shall be implemented and inspected accordingly in compliance with the permit throughout the construction process.

Noise Control: The construction contractor will be responsible for keeping construction noise levels within an acceptable range according to applicable County standards and ordinances.

Dust and Emission Control Plan: The construction contractor will prepare a dust and emission control plan prior to construction. The plans shall provide, at a minimum, measures to reduce dust and emissions (by minimizing idling time of diesel-powered equipment, apply water to disturbed areas, restrict grading and earth moving operations when wind speeds exceed 20 mph, etc.)

1.3 POPULATION TRENDS

Since the 1990's the City of San Juan Bautista has experienced a slow, but steady, rate of growth. According to census data, the City has grown from a population of 1,390 (in 1990) to a population of 1,862 (in 2010), as shown in **Table 1**. This equates to an approximate annual growth rate of 1.5%.

In accordance with the 2014-2018 American Community Survey (ACS) 5-year estimates, the population in 2018 was 1,965. This intermediate measurement shows a slowing in the growth for the rural community.



Table 1 San Juan Bautista Population Data

Year	Population
1990	1,390
2000	1,548
2010	1,862
2018 (ACS)	1,965
2020*	2,030
2030*	2,247

*Projections based on least regression model.

1.4 COMMUNITY ENGAGEMENT

In the City’s efforts to achieve the project objectives, public involvement is an important aspect of the overall plan, so that the City residents and businesses know what the City is doing with their water resources (potable water and wastewater), why, and how the City intends to 1) protect public health and enhance the environment, 2) comply with pertinent laws and regulations, 3) protect the value of properties served by the water and wastewater utilities, and 4) fund the improvements. Primary outreach efforts include:

- Community Workshops
- Community Survey
- Utility Bill Inserts
- Board Meetings

The need for wastewater treatment improvements has been known by the City for many years, as the plant has been out of compliance since the 2009 NPDES permit was adopted, and has been discussed over the years at many City Council meetings with public discussion and discourse. Most recently, there was a City Council and community workshop held on February 15, 2020, to set goals for the City (including water and wastewater treatment). Further, the City initiated a community survey to identify what is important to ratepayers. The survey was mailed to every resident in the March 2020 water utility bill. Additionally, presentations have been made by City Staff to the Council related to the project, including (most recently) on April 21, 2020. These presentations included opportunity for public involvement during the public comment period.

2.0 EXISTING WWTP FACILITIES

The existing San Juan Bautista Wastewater Treatment Plant (WWTP) is a tertiary treatment facility and is described herein.



2.1 LOCATION MAP

The existing treatment facility site layout is shown in **Figure 2**.



Figure 2 San Juan Bautista WWTTP Site Layout



2.2 HISTORY

The original wastewater treatment plant was a facultative pond plant. The last major improvements project, in 2010, upgraded Pond 1 to an aerated pond that functions as sequencing batch reactors (SBR) and split Pond 2 into three cells (Cell A, B, and C). Cell C functions as a denitrifying polishing pond, while cells A and B are used as sludge storage lagoons. The 2010 upgrade project also added a mechanical basket screen (in the headworks), a new dual media pressure filtration system, and UV disinfection system. In 2018, the City removed 30-years of accumulated sludge from Pond 2, to accommodate continued operation of the treatment plant.

2.2.1 Flows and Load Characterization

Historical Flows

Influent flow data for the period from January 2016 to April 2020 were obtained and analyzed. Data shown herein is in gallons per day (gpd) or million gallons per day (Mgal/d). Daily, monthly and annual average flows are shown in **Figure 3**. The monthly flow was calculated as the rolling 30-day centered average based on the period from 14 days before to 15 days after the day in question. The annual average flow was calculated as the rolling 365-day centered average based on 182 days before to 182 days after the date in question. As shown, there are large flow spikes throughout the year and these correspond to dates when there were large storm events (January 2017 storm event resulted in 14-inches of rainfall in the month and February 2019 resulted in 7.5-inches of precipitation) and/or when industrial dischargers send wash water to the WWTP (annual average daily flow rate of 25,000 gpd and max day of 100,000 gpd).

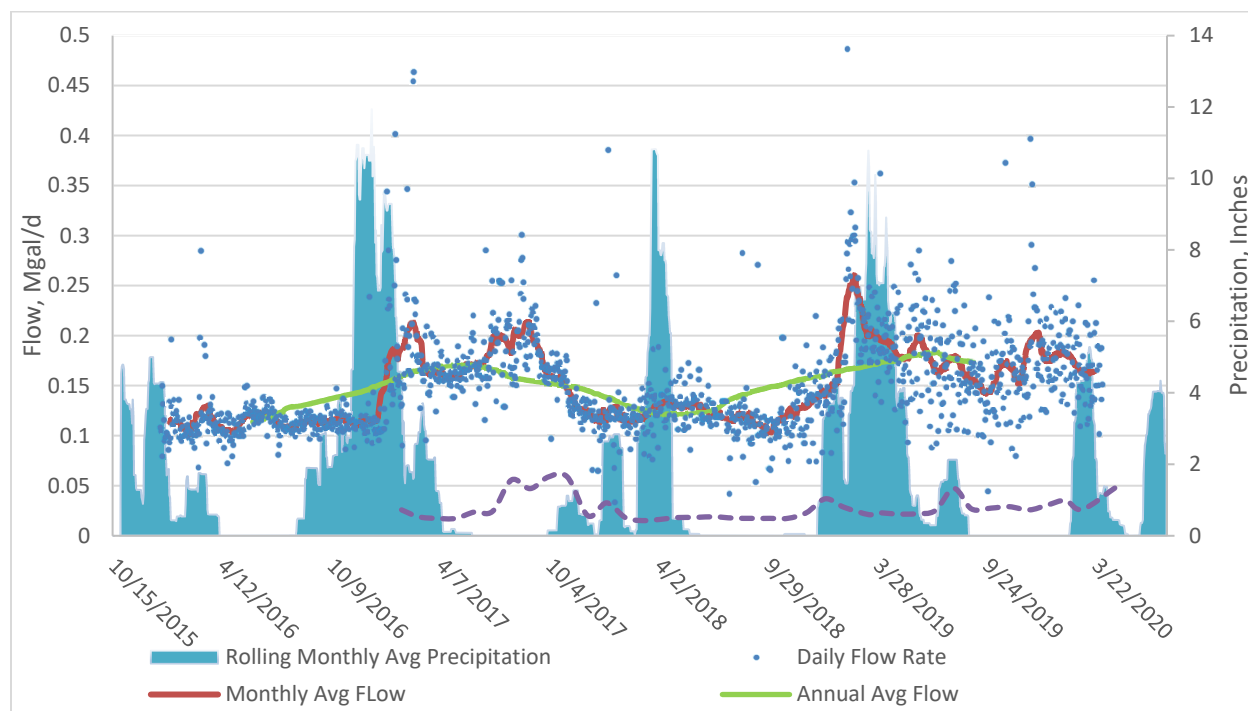

Figure 3 WWTP Historical Influent Flow Rates



The ratio of the daily flow and monthly flow to the annual average flow is plotted in **Figure 4**. The ratios of peak month flow and peak day flow to the AAF is 1.58 and 2.97, respectively as shown in **Figure 4**. The average dry weather flow (ADWF) was calculated as the average daily flow from June 1st through August 31st each year. The data shows that the AAF is nearly identical to ADWF, which indicates minimal inflow/infiltration and that industrial dischargers has a large impact on season flow, see **Table 2**.

The peak hour flow is an important parameter for wastewater treatment plant design because the headworks and the influent pumping must be designed to handle the short-term peak flows. There are no hourly logs available at the plant and so the peak hour flow ratio is assumed to be 4.0.

Based on the above data analysis, the recommended flow peaking factors are as follows:

Average Dry Weather Flow / Annual Average Flow (ADWF / AAF) = 1.0 (Table 2)

Max Month Flow / Annual Average Flow (MMF / AAF) = 1.58 (Figure 4)

Peak Day Flow / Annual Average Flow (PDF / AAF) = 2.97 (Figure 4)

Peak Hour Flow / Annual Average Flow (PHF / AAF) = 4.0 (assumed)

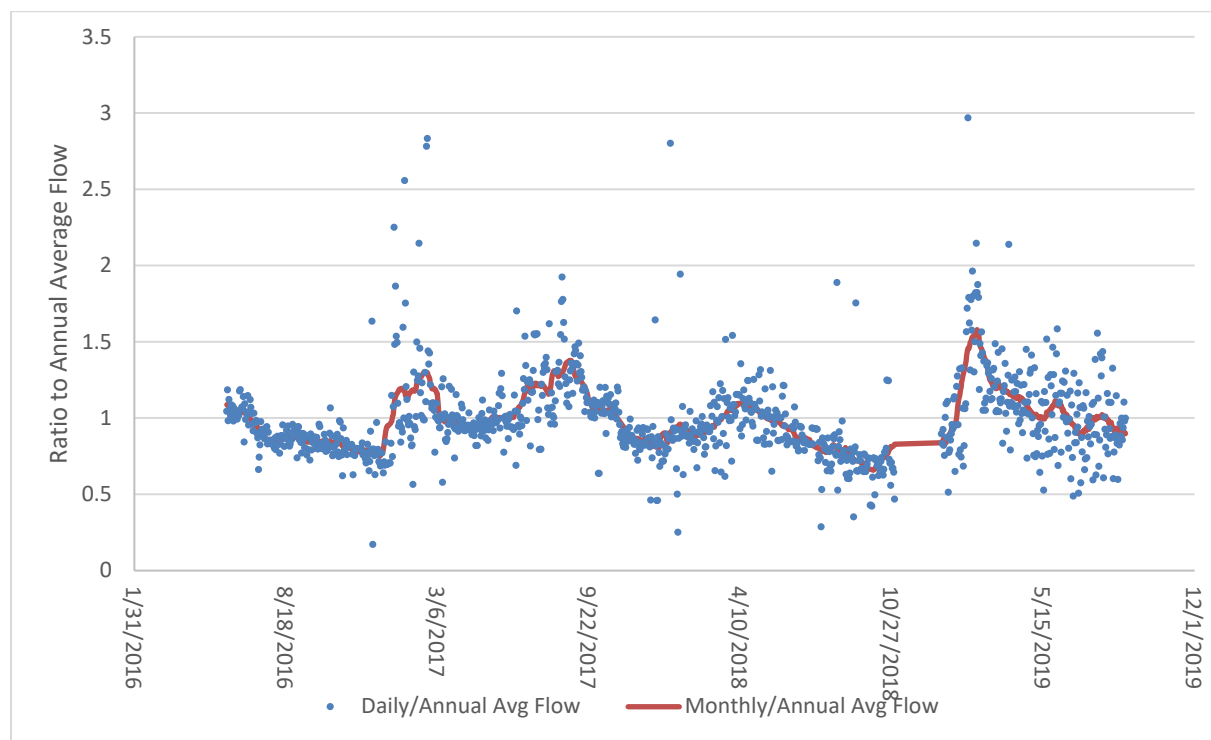

Figure 4 Flow Peaking Factors (Ratio of Daily and Monthly Flow to AAF)



Table 2 Relationship Between ADWF and AAF

Year	ADWF Mgal/d	AAF, Mgal/d ^(a)	ADWF/AAF Ratio
2016	0.12	0.11	1.01
2017	0.19	0.17	1.12 ^(b)
2018	0.12	0.12	1.00
2019	0.17	0.18	0.96

a) Calculated as the average daily flow during a specific year

b) Industrial Dischargers contributed to 25% of the flow during the 2017 summer months, skewing the ratio

Historical Loads

Plant influent Biochemical Oxygen Demand (BOD) and Total Suspended Solids (TSS) concentrations from January 2016 to March 2020 were obtained and analyzed. Samples were flow based proportional composites (although the solenoid valve that is supposed to automatically open to take the sample has become unreliable, making the sample not fully representative of the entire day’s loading). These samples were taken twice a month. BOD and TSS concentrations (mg/L) and daily influent flows were used to calculate the influent load (lb/d). As shown in **Figure 5**, the annual average BOD and TSS loads were calculated to be 334 lb/d and 351 lb/d, respectively.

Both influent BOD and TSS concentrations were highly variable beginning in 2018. Historically, samples were collected only on Thursdays. However, beginning in 2018, samples were also collected on the weekends (Friday and Saturday). Because there is a high concentration of restaurants within the City that accommodate out of town tourists, it is likely that weekend concentrations are higher than weekdays.

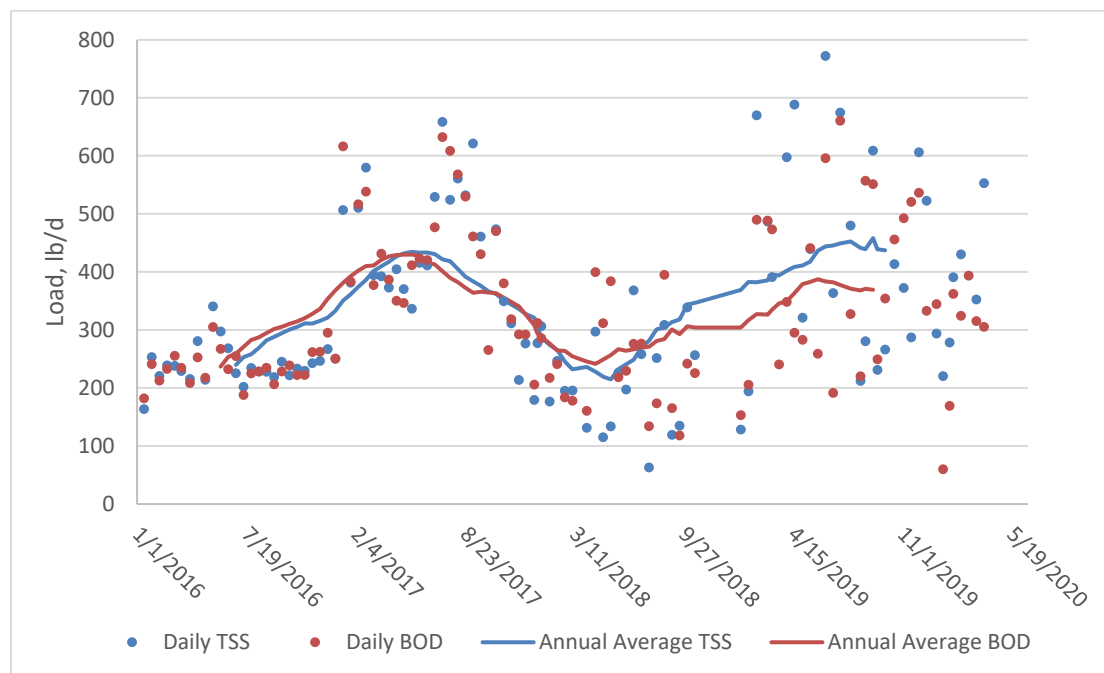

Figure 5 Influent BOD & TSS Loading



As a reality check, the average BOD expected from San Juan Bautista was calculated based on the City’s population of approximately 1,900 capita and the typical BOD generation of 0.22 lb/capita/day when disposal grinders are utilized in the community or 0.18 lb/capita/day without grinders (Metcalf and Eddy, 4th edition). The resulting BOD load is between 342 and 418 lb/d, which is within the range observed from the historical sampling. As such, it is assumed that the existing annual average BOD load into the plant is 420 lb/d. It is noted that the loading increases during the summer of 2017 and 2019, likely from the industrial discharges as they are providing a higher flow rate during summer months of those two years.

However, the ratio of TSS to BOD was also variable beginning in 2018, which could be attributed to non-representative sampler withdrawal location. As shown in **Figure 6**, the ratio was around 1.0 until 2018 and then fluctuated between 0.5 and 2.1 thereafter. The typical value of TSS/BOD for municipal wastewater ranges from 1.0 to 1.1; a ratio of 1.1 was selected.

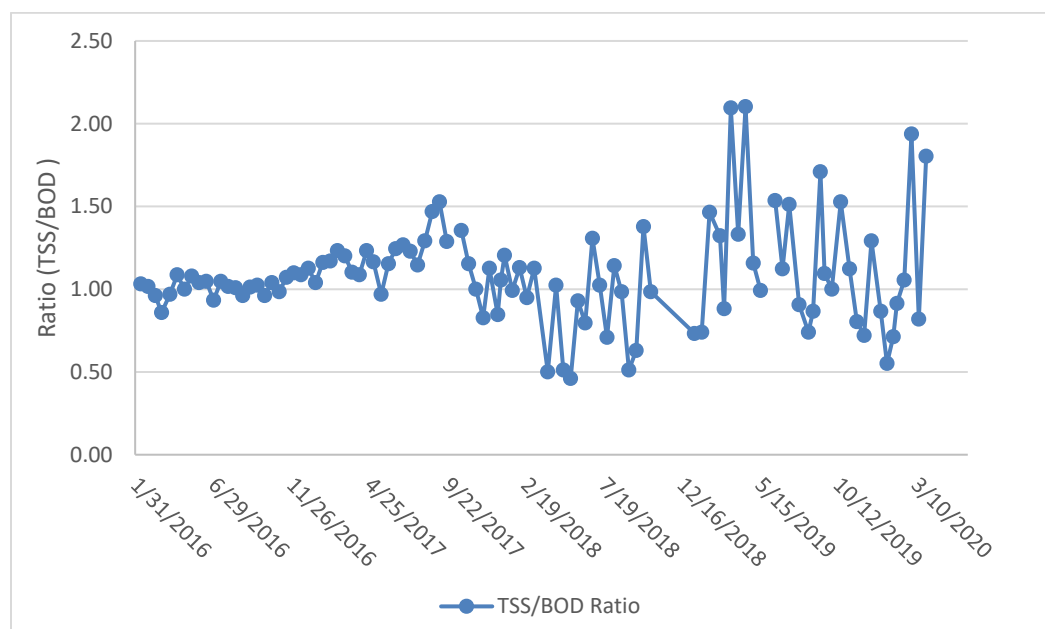

Figure 6 Influent TSS to BOD Ratio

Loading Peaking Factors

The size of the reactor basins should be large enough to accommodate a peak month load. Therefore, the ratio of the peak month load to the annual average load is an important design parameter. The ratios of the average day maximum month load (ADMML) to average annual load (AAL), for BOD and TSS, are shown in **Figure 7**. Since the historical load data is questionable, it is recommended to use a typical peak month load factor of 1.4 (adopted from Figure 3-8, Metcalf and Eddy, fourth edition), which is similar to the ratios found in the data prior to 2018.

Influent total Kjeldahl nitrogen (TKN, or ammonia plus organic nitrogen) is an important parameter that needs to be determined for plant design. The typical value of TKN/BOD for municipal wastewater ranges from 0.17 to 0.21. A conservative ratio of 0.19 is selected for design.



SAN JUAN BAUTISTA, WASTEWATER TREATMENT IMPROVEMENTS PROJECT

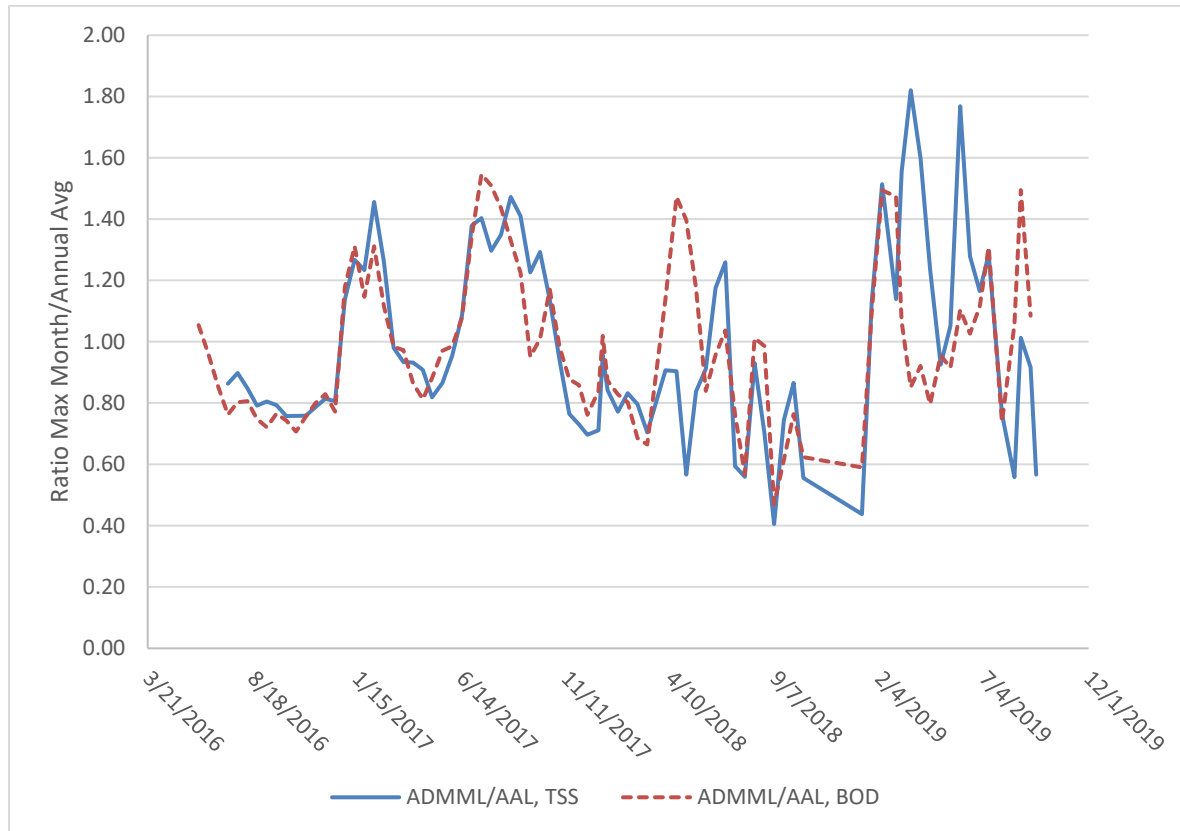

Figure 7 BOD and TSS Peaking Factors (Ratio of ADMML/AAL)



Historical Salt Concentrations

The data presented in this section provides the most up to date characterization of influent wastewater salt concentrations, so that effluent concentrations can be projected for this project. These samples were taken once a month, using a grab sample technique, which means each sample represents the wastewater concentration at a single point in time. The discharge permit issued by the Regional Board currently includes (and is expected to continue to include) limitations for TDS, chloride, and sodium. As shown in **Figures 8 to 11**, both the influent loading (lb/d) and influent concentrations have increased, likely due to the increasing population (adding associated flow) and water conservation measures, as well as continued discharge from the industrial dischargers. When people conserve water, the mass of pollutants (salt) discharged by each person remain unchanged, but because that mass is conveyed with less water, it results in higher pollutant concentrations arriving at the wastewater treatment facility.

The annual average influent concentrations for chloride and sodium are 600 mg/L and 300 mg/L, respectively, and the annual average concentration for TDS is 1800 mg/L.

A wastewater influent salinity balance is provided in **Section 2.5**, to document the likely contributors of salt loading on the plant.

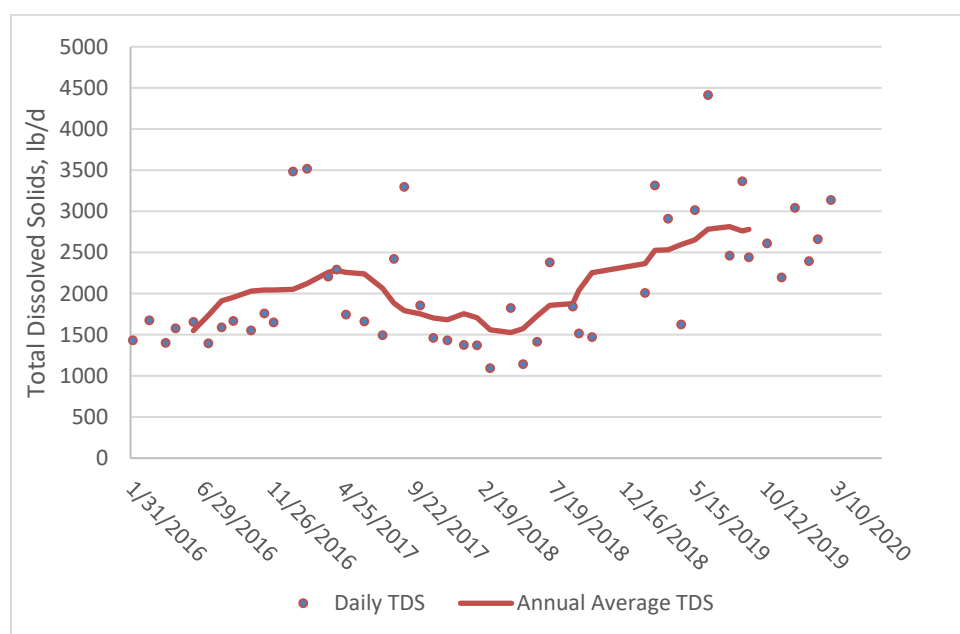

Figure 8 Influent TDS Loading



SAN JUAN BAUTISTA, WASTEWATER TREATMENT IMPROVEMENTS PROJECT

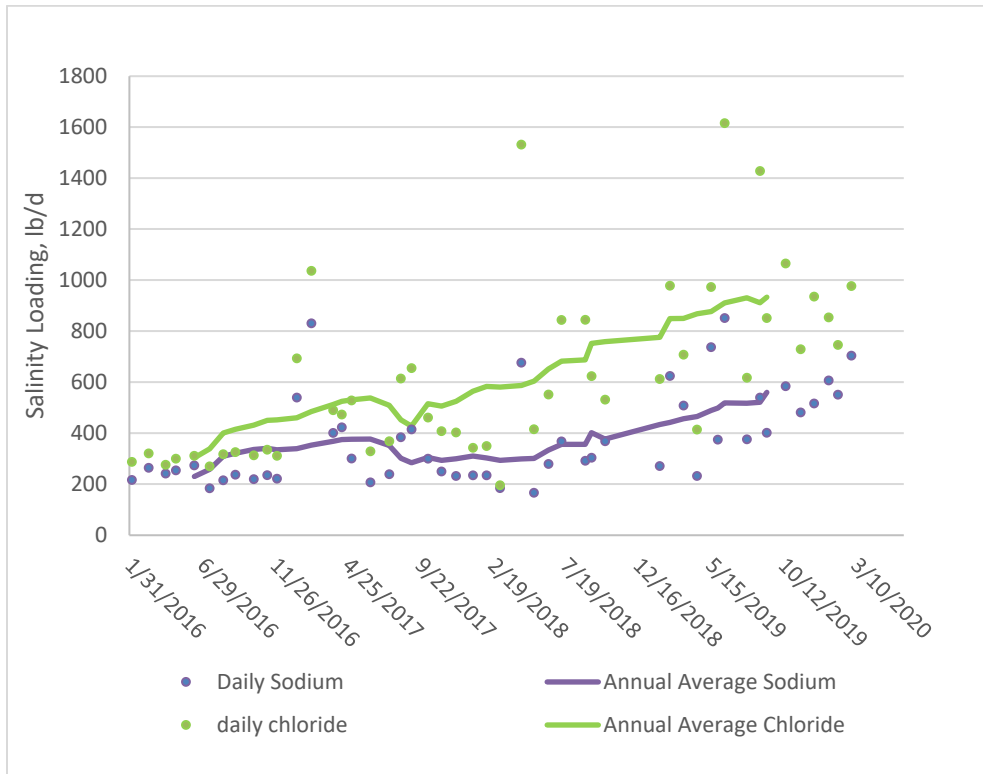

Figure 9 Influent Sodium and Chloride Loading

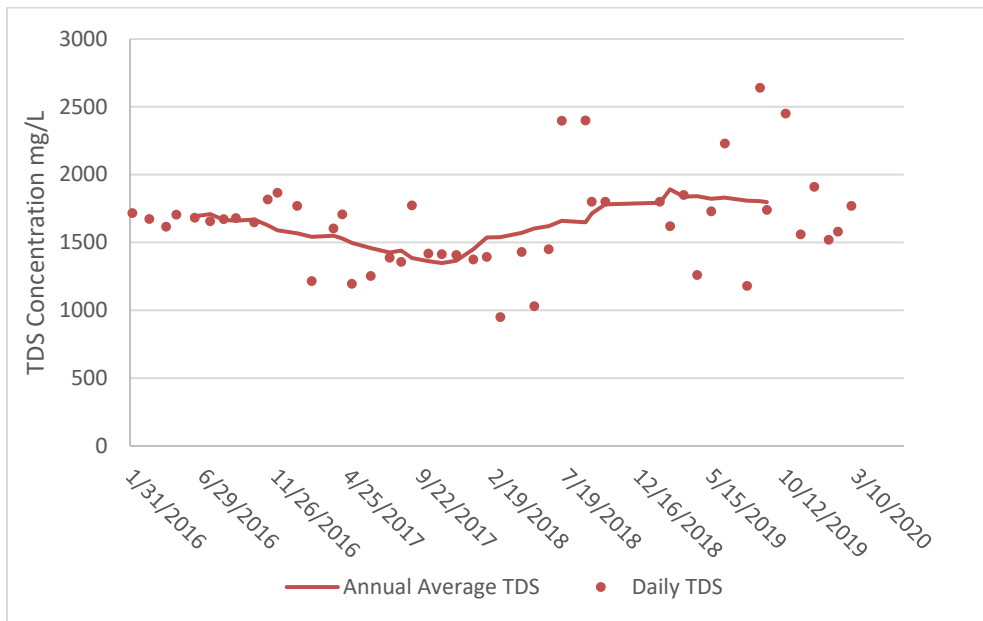

Figure 10 Influent TDS Concentration



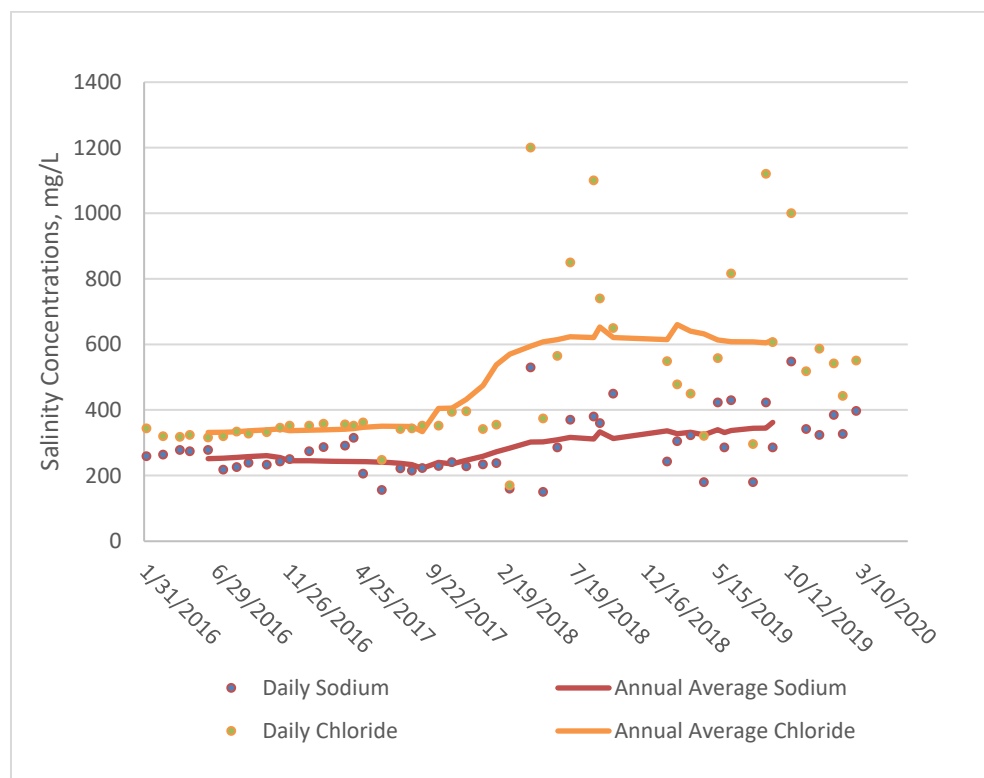

Figure 11 Influent Sodium and Chloride Concentrations

Source Water Salinity

The elevated chloride, sodium, and TDS levels observed in the City’s wastewater are thought to be driven, in part, by source water (groundwater) hardness and associated self-regenerating water softeners used for potable water treatment throughout the community. The existing groundwater wells produce very hard water (greater than 300 mg/L as CaCO₃) and, as a result, many of the City’s residents have installed domestic self-regenerating water softeners to provide local treatment. Water softeners exchange calcium and magnesium (the main constituents contributing to hardness) for sodium or common salt (sodium chloride, NaCl). This process results in elevated chloride, sodium, and TDS that is inevitably discharged to the City’s wastewater collection system and negatively impacts the WWTP. For comparison, the relative hardness scale is provided as follows:

- **Soft:** 0 to 75 mg/L as CaCO₃
- **Moderate:** 75 to 150 mg/L as CaCO₃
- **Hard:** 150 to 300 mg/L as CaCO₃
- **Very Hard:** Above 300 mg/L as CaCO₃



Water quality data for the existing potable water supply wells (Well No. 1, Well No. 5, and Well No. 6) are shown in **Table 3**, below. For an analysis on the overall impact of the source water on the wastewater salinity budget, refer to **Section 2.5**, which documents the likely contributors of salt loading on the plant.

Table 3 Source Water Chemistry for Existing City Wells

Constituent	City Well 1 (Raw)	City Well 5 (Raw)	City Well 6 (Raw)
pH (std. units)	6.7 – 8.0	7.5	7.7 – 8.1
Hardness as CaCO ₃ (mg/l) (mg/l)	353 – 485	321	334 – 371
Alkalinity as CaCO ₃ (mg/l)	278 – 360	320	380
TDS (mg/l)	499 – 760	550	640 – 750
Chloride (mg/l)	61 – 100	81	89 – 110
Sodium (mg/l)	47 – 100	72	130 – 140

As documented in the 2020 Water Master Plan (Appendix A), the City currently uses Well No. 1 as their primary water source for much of the year. As demands increase, Well No. 1 cannot keep up with high flow rates and requires Well No. 5 to provide additional flow. Well No. 5 requires iron and manganese treatment prior to distribution, as the raw water concentrations exceed the secondary maximum contaminant levels (MCLs). Well No. 6 is the preferred primary producer but has been taken off-line due to high nitrate contamination, which hasn't yet been isolated or controlled.

The salinity balance in Section 2.5 is based on use of Well No. 1 as the current primary source water.

Industrial Wastewater Salinity

In addition to domestic water softeners contributing to elevated chloride, sodium, and TDS levels, industrial wastewater is also driving the elevated salinity at the WWTP influent. Taylor Farms, an of the industrial dischargers to the sewer collection system, is an agricultural processing facility that washes produce with what is believed to be a sodium hypochlorite solution (or NaCl, which is industry standard for disinfecting food, prior to packaging). As detailed in **Table 4**, this disinfection method adds substantial salinity loading to wastewater influent (from the facility's discharge). Because there is no pre-treatment program in place for the City's industrial users, there is no historical monitoring data (other than flow rate information) for the industrial users. Industrial users, including Taylor Farms, have been discharging into the City's collection system since 2003. Because the City was in violation of chlorides prior to Taylor Farm's connection (as detailed in **Appendix C**), it is believed the salinity problem cannot be completely resolved by eliminating this source. However, the industrial users have certainly exasperated the salinity problems at the WWTP, as described herein.

To get a better understanding of the concentrated loadings being discharged into the system, the City sampled industrial users wastewater (prior to mixing with any other sources of sanitary sewers), as documented in **Table 4**. Although only two weeks of composite samples were taken (on 6/26-7/9/2020), it provides important insight into the impacts that industrial users have on the City's municipal wastewater treatment plant. It is recommended that the City take additional samples to get a better understanding of how the loads change daily and seasonally.



Table 4 Industrial Drain Sampling Data

Constituent	Concentration ¹ , mg/L	Average Load, lb/d ²	Peak Load, lb/d ³
TDS	3816	878	1910
Chloride	1623	373	812
Sodium ⁴	950	219	475

1. Concentrations based on composite sampling event from 6/26/2020 to 7/9/2020
2. Average load based on average load and average flow rate of 27,600 gal/d
3. Peak load based on average load and max month daily flow rate of 60,000 gpd
4. Sodium nitrate is added to the pump station for odor control at a rate of 40 lb NaNO₃/month (= 10.8 lb sodium/month = 0.36 lb/day). As such, 0.2% of the sodium load from the industrial facility is added by the City (and not attributed to the industry).

The City of San Juan Bautista is not required to have an industrial pre-treatment program, as the WWTP flow rates are under the Regional Board’s mandated threshold. However, many treatment plants require industrial dischargers to comply with certain guidelines prior to sending flow to the sewers. When pre-treatment guidelines are implemented, they help limit impacts on downstream wastewater treatment and disposal facilities and help reduce the burden on residential ratepayers (who would otherwise need to offset the treatment costs associated with a few high-impact users).

As graphically depicted below, industrial wastewater is typically 15-percent of the monthly wastewater influent flow rate (peak week events reaching 40-percent and daily peaks reaching 60-percent of the influent daily flow rate, in 10/5/2017 and 9/25/2019), but calculated loading contribution are much higher (typically contributing to 30% influent salinity loading). Refer to **Section 2.5** for an analysis of the industrial wastewater discharger’s impact on the WWTP influent salinity balance, which documents the likely contributors of salt loading on the plant.

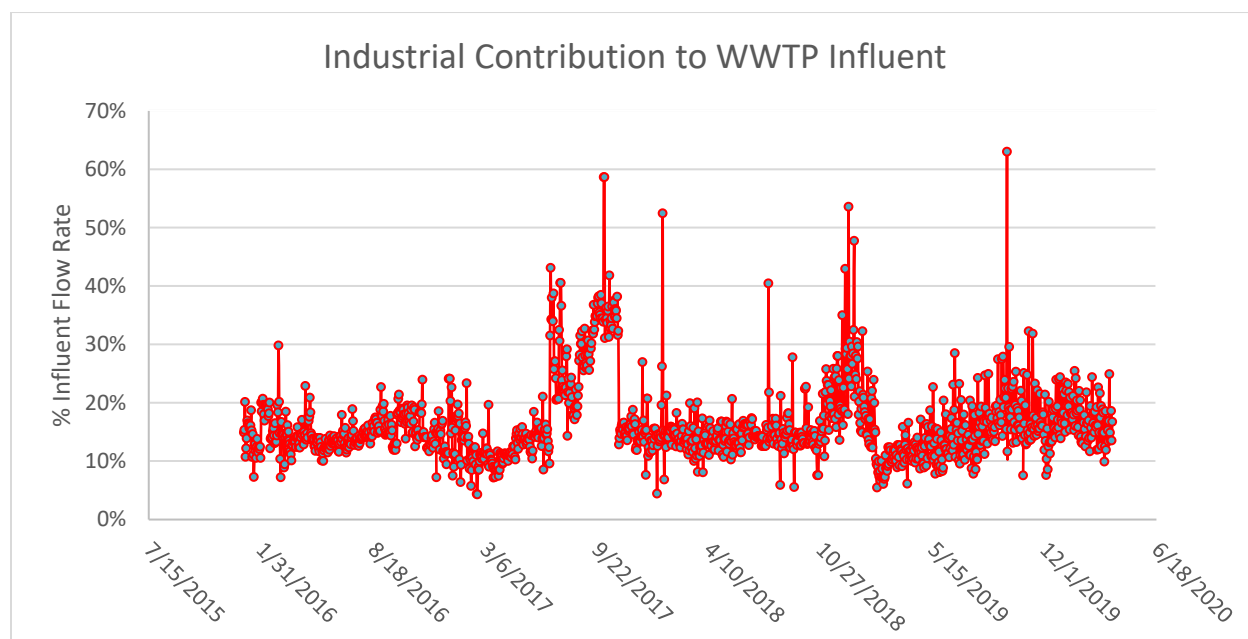

Projected Design Flows and Loads

The current wastewater flows and loads presented above are used for projecting future flows and loads. Future increases in all sewage flows and loads are expected to be proportional to increases in average annual flows, which should be roughly proportional to the number of sewer connections and/or population growth. The projections further assume that all the commercial development will increase loads proportional to existing values and future industrial connections will have pre-treatment programs to ensure loading is similar to residential/commercial properties. Based on these assumptions, flow and load peaking factors will remain at current values. The Phase 1 design criteria is based on the permitted treatment capacity of 0.27 Mgal/d (ADWF). The full buildout of the service area is based on a flow rate of 0.48 Mgal/d, as described in the 2020 Wastewater Master Plan, as shown in **Appendix A**. Wastewater flows and loads for the San Juan Bautista WWTP Improvement Project are included in **Table 5**.

Table 5 WWTP Design Flows and Loads

Parameter	Unit	Current Condition ADWF = 0.18 Mgal/d	Phase 1 Condition ADWF = 0.27 Mgal/d	Buildout Condition ADWF = 0.48 Mgal/d
Flow				
Average Dry Weather Flow (ADWF)	Mgal/d	0.18	0.27	0.48
Avg. Day Annual Flow (AAF)	Mgal/d	0.18	0.27	0.48
Average Day Max Month Flow (ADMMF)	Mgal/d	0.29	0.43	0.75
Peak Day Flow (PDF)	Mgal/d	0.54	0.80	1.42
Peak Hour Flow (PHF)	Mgal/d	0.72	1.08	1.91
Biological Oxygen Demand (BOD)				
Annual Average Load (AAL)	lb/d	420	628	1,110
Avg. Day Max Month Load (ADMML)	lb/d	588	879	1,553
Average Concentration	mg/L	279	279	279
Max Month Concentration	mg/L	390	390	390
Total Suspended Solids (TSS)				
Annual Average Load (AAL)	lb/d	462	691	1,220
Avg. Day Max Month Load (ADMML)	lb/d	647	967	1,709
Average Concentration	mg/L	307	307	307
Max Month Concentration	mg/L	430	430	430
TKN Concentration				
Annual Average Load (AAL)	lb/d	80	119	211
Avg. Day Max Month Load (ADMML)	lb/d	112	167	295
Average Concentration	mg/L	53	53	53
Max Month Concentration	mg/L	74	74	75
Total Dissolved Solids⁴	mg/L	1800	1800	1800
Chloride⁴	mg/L	600	600	600
Sodium⁴	mg/L	300	300	300

1. If water conservation measures materialize, then the design organic load of the plant will be reached before the hydraulic design flow.
2. Average concentrations are calculated using AAF combined w/AAL
3. Average day max month load is calculated using AAF combined w/ADMML
4. Salinity concentrations shown are prior to source control reduction (pretreatment & potable water improvements)



2.3 CONDITION OF EXISTING FACILITIES

The San Juan Bautista WWTP is a tertiary treatment facility that includes a mechanical screen and influent pump station, sequencing batch reactor pond (SBR, located in Pond 1), flow equalization tanks, a denitrification pond (located in Pond 2C with floating media), pressure sand filters, and ultraviolet (UV) disinfection. Sludge is stored in lagoons (Pond 2A and 2B).

2.3.1 Process Descriptions and Summary of Condition

Raw sewage enters the WWTP in the headworks, where a mechanical auger screen removes large debris from the incoming wastewater. Screened raw sewage is pumped to the SBR (Pond 1, Cell No. 1 or Cell No. 2). As with other conventional activated sludge SBR facilities, aeration and mixing is achieved in batch cycles (sending flow into one half of the pond while the other half is decanted). Once the biological reaction is complete, sludge settles, and supernatant is discharged to equalization storage tanks (70,000-gallon tanks). Waste activated sludge is withdrawn from the SBR and sent to the sludge storage lagoons (Pond 2A/2B).

After equalization, flow passes through the polishing pond (Pond 2C), where secondary effluent is mixed with polymer. The blended solution flows through multimedia sand filters to reduce suspended solids and turbidity. Filtered effluent is sent through a UV disinfection channel and discharged to the outfall.

Table 6 identifies the original design criteria established for the existing WWTP, as defined in the operation and maintenance manual. When comparing the existing design criteria to the current loading conditions shown in **Table 5**, the secondary treatment process is already beyond its design capacity. Further, the WWTP was never designed to remove salinity from the waste stream.

Table 6 Existing WWTP Design Criteria

Parameter	Unit	Existing WWTP Design Criteria ¹
Influent		
Secondary Capacity	Mgal/d	0.27
Tertiary Capacity	Mgal/d	0.20
BOD ₅ Loading	lb/d	357
BOD ₅ Concentration	mg/L	210
TSS Loading	lb/d	399
TSS Concentration	mg/L	235
Effluent		
Avg Month BOD ₅ Concentration	mg/L	20
Daily Max BOD ₅ Concentration	mg/L	60
Avg Month TSS Concentration	lb/d	20
Daily Max TSS Concentration	mg/L	60

1. Existing WWTP Design Criteria, as defined in the O&M manual.



SAN JUAN BAUTISTA, WASTEWATER TREATMENT IMPROVEMENTS PROJECT

In addition to the secondary facilities being apparently undersized (design capacity is lower than current loading rates), the plastic partition wall between the sludge storage lagoon (Ponds 2B and 2C) and the polishing pond (Pond 2A) is not sealed, allowing sludge to leach into the secondary effluent. Due to this inadvertent mixing of sludge and secondary effluent, the plant is at risk for discharge violations. For long term compliance, the sludge storage ponds need to be completely separated from the process flow stream.

Figure 12 is a picture of Pond 2, including the sludge storage lagoon and polishing pond.



Figure 12 Partition Wall Between Sludge Storage Lagoon and Polishing Pond

Further, the tertiary treatment facility is only designed to handle 0.2 Mgal/d, which is 80,000 gpd less than the existing maximum month average day flow rate ($0.28 - 0.20 = 0.08$ Mgal/d = 80,000 gpd). While there is some buffering capacity available in the SBR (the entire pond volume is 1.6M gallons), the available volume is not enough to equalize the excess daily flow for an entire month (totaling 2.4M gallons of excess wastewater in one month). For long term compliance, the tertiary treatment train needs to be expanded to accommodate higher flow rates (equalizing to annual average flows is not cost effective).



2.3.2 Discharge Permit Compliance Issues

The San Juan Bautista Wastewater Treatment Plant (WWTP) operates under Order No. R3-2009-0019 NPDES permit No. CA0047902. Below is a summary of the City's ability to comply with salinity, BOD, TSS, and Total Coliform effluent limitations.

Salinity Compliance

Amongst other effluent limitations, the average monthly discharge limits for chloride, sodium, and total dissolved solids (TDS) are 200 mg/L, 250 mg/L, and 1400 mg/L, respectively. As shown in **Figure 13**, the City was compliant except for chlorides, until 2018, and is now in violation of all three effluent limits.

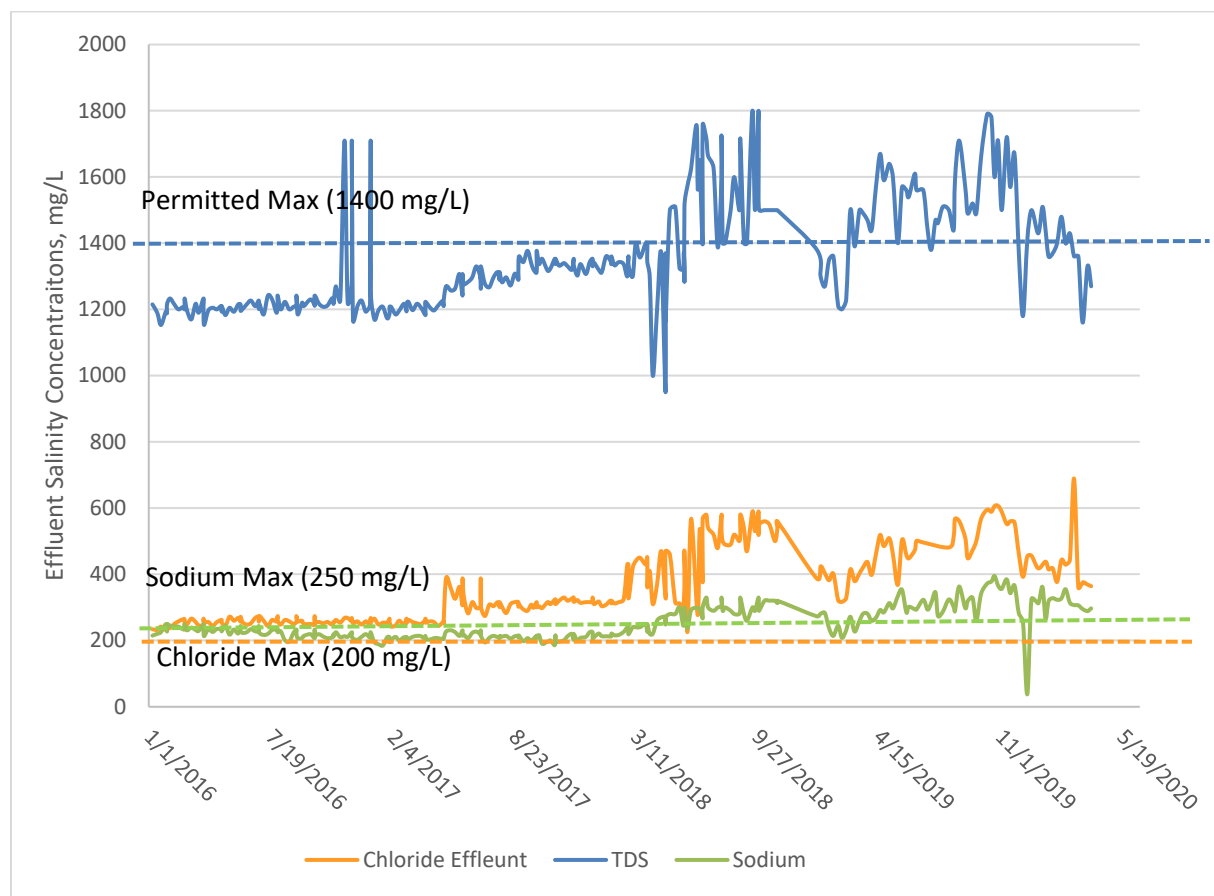

Figure 13 Effluent Monthly Salinity Concentrations



BOD and TSS Limitations

The NPDES permit limits effluent concentration for BOD and TSS to 20 mg/L (average monthly concentration) and 60 mg/L (daily maximum concentration). The plant has historically met these limits, as shown in **Figure 14**. There were three days in 2018 (August 16, August 31, and September 30) where the effluent TSS concentration was reported to be 310 mg/L. These outlier days were removed from the graph shown below because duplicate samples taken on the same day show much lower values (around 30 mg/L) and the low values match those of surrounding days (whereas 310 mg/L would be expected in the wastewater influent, not effluent). However, there were still two events in 2019 that resulted in TSS exceeding the maximum daily limit. Further, there were several exceedances of the monthly average limits for both BOD and TSS. It is likely that the samples from August and September were affected by the sludge dredging operations, which occurred in the same time period, as further explained below.

Because the plastic partition wall between the sludge storage lagoon (Ponds 2B and 2C) and the polishing pond (Pond 2A) is not sealed, sludge leaches into the secondary effluent. Due to this inadvertent mixing of sludge and secondary effluent, the plant is at risk for discharge violations. In 2018, the City removed the accumulated sludge from Pond 2B and 2C and the operations staff was able to stabilize the biology by the following summer and have remained compliant with effluent BOD and TSS limitations since that date. However, for long term compliance, the baffle walls need to be rebuilt and the sludge storage ponds need to be completely separated from the process flow stream.

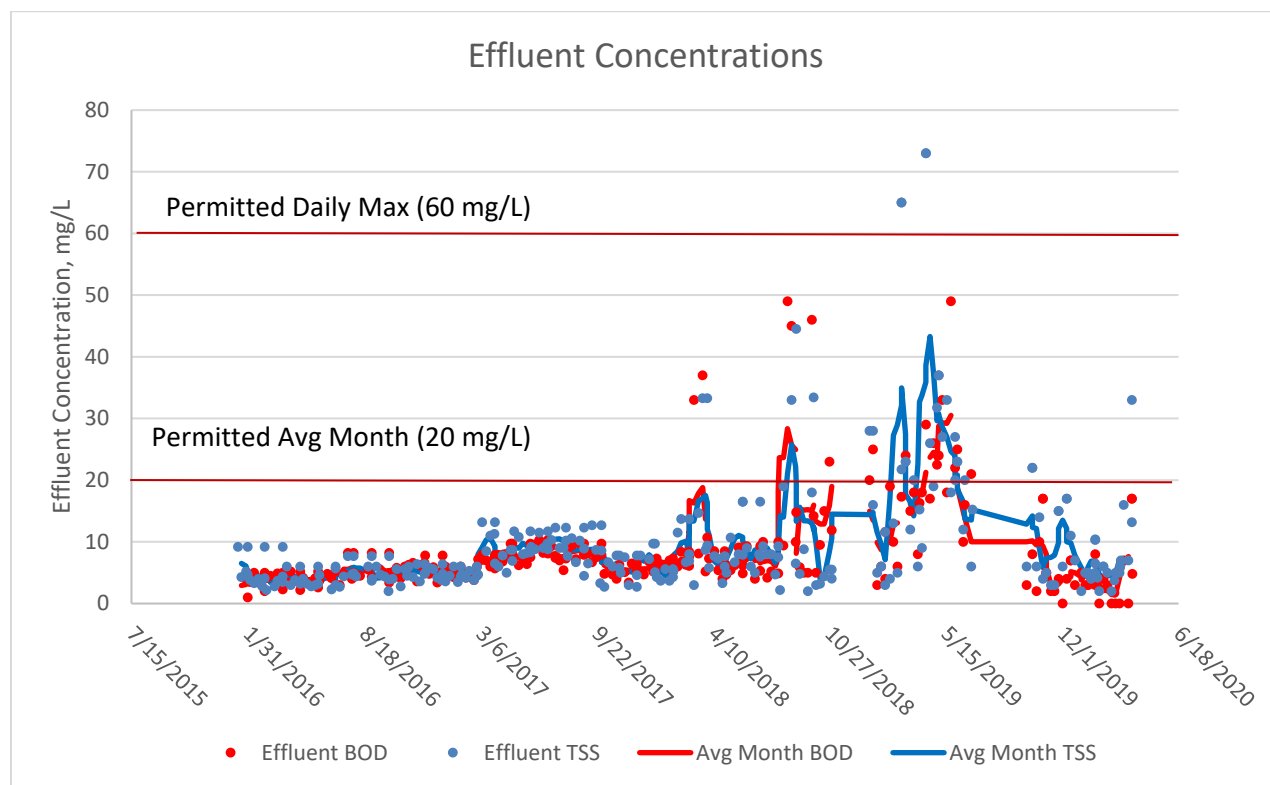

Figure 14 BOD and TSS Effluent Concentrations



Total Coliform Limitations

The permitted effluent limitation for total coliform is 23 MPN/100mL (five-day median concentration) and 2300 MPN/100mL (daily maximum concentration). The plant has historically met these limits, as shown in **Figure 15 and 16**. However, between February and April of 2019, there were several exceedances of both daily and five-day median total coliform. The discharge violations were likely due to UV bulb/sleeve aging and potentially due to undersized equalization facilities. After the city replaced cracked UV bulbs and broken sleeves (in summer of 2019), the coliform has remained compliant with discharge limitations. For long term compliance, all UV disinfection equipment must be maintained and replaced in accordance with the manufacturer’s guidelines and upsized (or re-rated) to handle flow rates higher than the annual average flow.

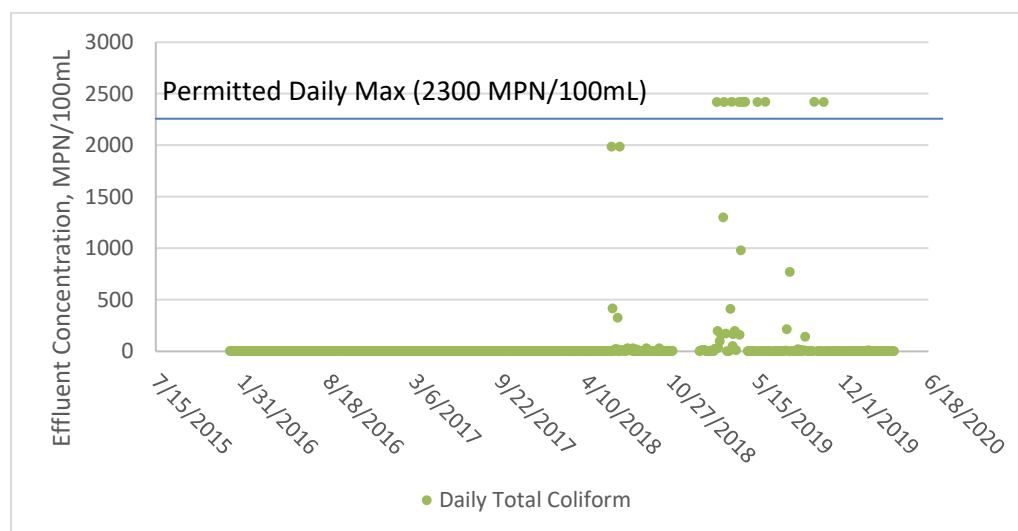

Figure 15 Daily Total Coliform Effluent Concentrations

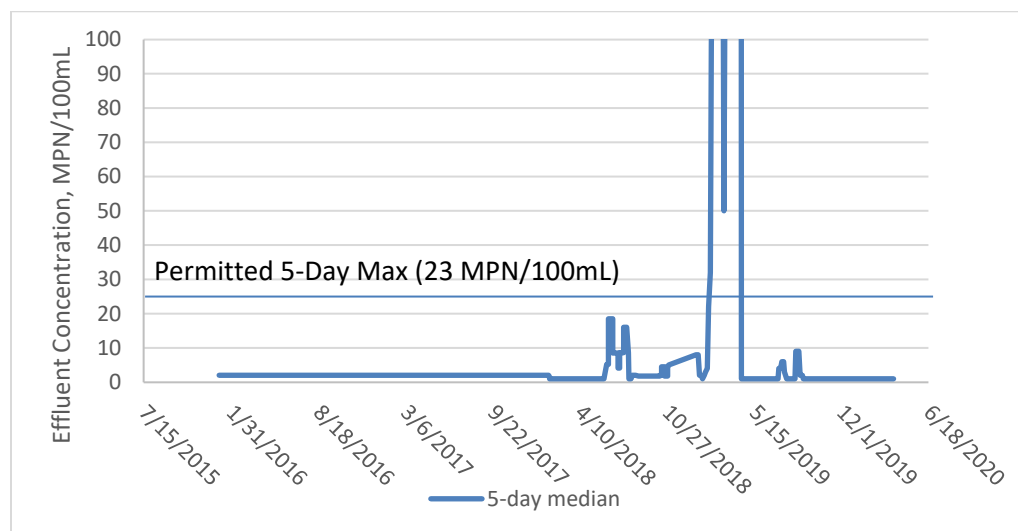

Figure 16 Five-Day Median Total Coliform Effluent Concentrations



2.4 FINANCIAL STATUS OF EXISTING FACILITIES

The median household income (MHI) for the City of San Juan Bautista is \$53,077, which is 74.5% of State average, and has a population of approximately 2,030. A comprehensive operating budget for the City is attached to the project application (see **Appendix B**) and includes detailed expenses and assets associated with the City’s budget. The City prepared a Rate Study in 2015 and adopted new sewer rates with Ordinance 2015-20, which is summarized as:

- the base rate of \$83.61/month (residential),
- \$84.03 (commercial), and
- Cost per 1,000 gallons: \$9.10/month (standard strength), \$13.63/month (moderate strength), and \$18.18/month (high strength).

There are currently 908 residential, commercial, industrial, and institutional sewer connections.

The 2020 Water and Wastewater Masterplan (in **Appendix A**) includes a capital improvement program for major upcoming projects, including the recommendations from this report. **Table 7** shows the sewer operating revenue and expenses from June 2019 Auditor’s Report and Financial Statement.

Table 7 Financial Status, 2019 Auditor’s Report

Assets	Sewer
Operating Revenue	1,182,920
Operating Expense	
Contractual Services and Utilities	291,529
Personnel	113,110
Supplies, Materials, and Repairs	573,351
Depreciation	308,686
Total Operating Expense	1,286,676
Non-Operating Revenue / (Expense)	
Development Impact Fees	163,993
Interest Income	22,349
Interest Expense	(220,954)
Total Non-Operating Revenue / (Expense)	(34,612)



2.5 WASTEWATER AUDITS

The City is in the middle of updating their water and wastewater masterplan, as shown in **Appendix A**. The results of which have been incorporated into this report. In addition to the wastewater audits from the masterplan, the following salinity information is important to document.

2.5.1 WWTP Influent Salinity Balance

Salinity (salt) is measured by the total concentration of dissolved minerals, such as magnesium, potassium, sodium, and chlorides. Once salinity is in wastewater, it is difficult to remove. All potable water contains naturally occurring salt, but water users (industrial, agricultural, and residential) also add salt to the water before discharging into the sewers. For example, households add salt to their drains from excess salt in their diet, and use of detergents, cleaning products, soaps, and shampoos. Salt is further added to sewers when it is exchanged for hardness in the self-regenerating water softeners.

As stated previously, many of the City's residents have installed domestic self-regenerating water softeners to provide local treatment to potable water. Water softeners exchange calcium and magnesium (the main constituents contributing to hardness) for sodium or common salt (sodium chloride, NaCl). This process results in elevated chloride, sodium, and TDS that is inevitably discharged to the City's wastewater collection system.

Further, the City receives flow from industrial dischargers (including Taylor Farms). Taylor Farms, an agricultural processing facility, washes produce with what is believed to be a mixture of sodium hypochlorite and a proprietary substance called SmartWash Solution (T128). While the disinfection and washing procedures of the facility are not known, it is assumed that sodium hypochlorite is used on site based on the sampling data reported herein and symposium presentations from the company at multiple agricultural conferences in the last decade. This disinfection method adds substantial salinity loading to the industrial discharge.

Based on **Table 4**, Taylor Farms (and possibly another industry) discharges 3816 mg/L TDS, 1623 mg/L Chloride, and 950 mg/L sodium and historical billing information (documenting daily and monthly flow rates) the facility discharges an average flow rate of 27,600 gpd (15% of the average influent daily flow rate). Although the flow rates from industrial dischargers are 15% (on average) of the total influent flow rate, they make up 40% of the influent chloride and sodium concentrations (and likely more during the peak month events). When the influent flow rate from industrial dischargers is higher (ratio of industry flow rate to total influent flow rate is more than 15%), the wastewater influent salinity concentrations go up.

Table 8 shows an estimated salt balance for the City of San Juan Bautista wastewater influent.

As shown in **Figure 17**, salt comes from many sources and requires careful consideration as to the best option for removal.

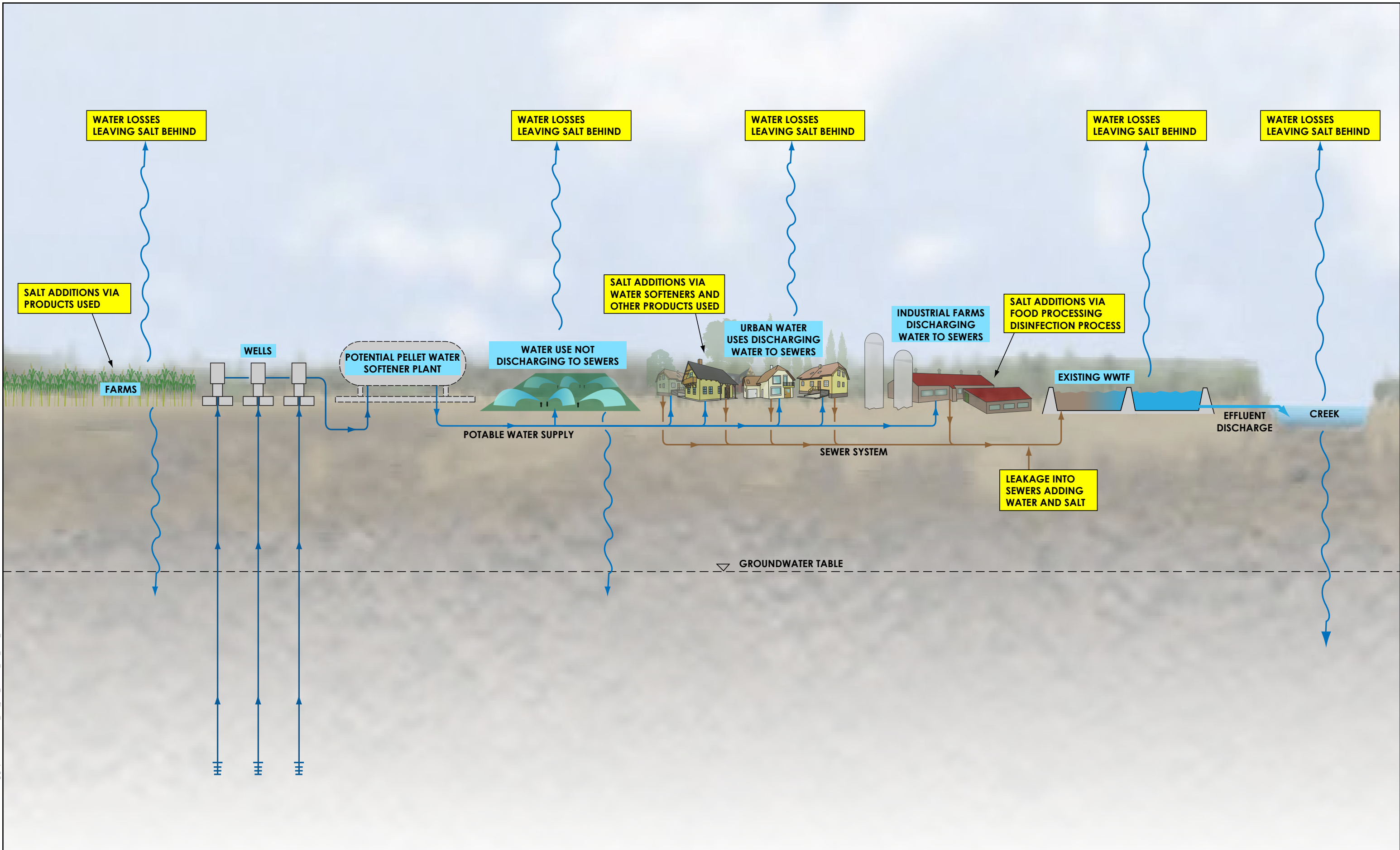

Table 8 WWTP Influent Salinity Balance (Average Daily Loads)

Salt Contributors to Total WWTP Influent	TDS	Chloride	Sodium
SALINITY LOADING, lb/d			
Well No. 1 (Raw Water) ¹	948	116	91
Diet and Personal Care Products ²	400	27	19
Self-Regenerating Water Softeners ³	545	327	218
Industrial User ⁴	878	373	219
Inflow and Infiltration ⁵	0	60	0
TOTAL WWTP INFLUENT, lb/d	2,772	904	546
SALINITY CONCENTRATION, mg/L			
Well No. 1 (Raw Water) ¹	628	77	60
Diet and Personal Care Products ²	265	18	12
Self-Regenerating Water Softeners ³	361	217	144
Industrial User ⁴	582	247	145
Inflow and Infiltration ⁵	0	40	0
TOTAL WWTP INFLUENT, mg/L	1836	600	362

1. Based on average well data shown in Table 3: 0.18 Mgal/d and TDS 628 mg/L, Chloride 77 mg/L, and Sodium 60 mg/L.
2. Dietary and Personal Care Products: TDS concentration of 265 mg/L based on Central Valley Clean Water Association "Salinity Management Practices for POTWs" 2012. Chloride and sodium concentrations based on "Chloride Contributions from Water Softeners and Other Domestic Sources" University of Minnesota 2019 and "Characterizing and Managing Salinity Loading in Reclaimed Water Systems" by AWWA & Thompson 2006.
3. Water softener efficiency based on 3300 grains hardness per pound NaCl (and average hardness 425 mg/L CaCO₃) in accordance with historical and current California efficiency standards and half the influent flow rate is being treated by ion exchange water softeners. Calculation assumes 40% of households have water softeners (approximately 350 softeners in use).
4. Industrial sampling from June 2020 on industrial discharge (27,600 gal/d and average concentrations of 3816 mg/L TDS, 1623 mg/L chloride, and 950 mg/L sodium). To correlate these values to total wastewater influent flow concentration, the sample concentrations were multiplied by 15% (27,600gpd ÷ 180,000gpd = 15%)
5. To account for missing salinity, inflow and infiltration (I/I) based loading (salinity from agricultural runoff and natural erosion/weathering of rock minerals) was calculated by taking the difference between historical influent loads (from Table 4) and total other loads contributors identified herein. The missing chloride concentration may also be linked to the historical changes in the primary source water, as various wells were placed online or taken offline (i.e. Well No. 1 has chloride concentrations that are 25 mg/L lower than Well No. 6, etc).





V:\18_00\active\184031254\drawing\graphical\184031254_sam_juan_bautista_salt_issue_schematic.dwg min 4-24-2020

While industrial dischargers provide 15-percent of the average wastewater influent flow rates, the peak month reaches 33-percent of the actual flows (60,000 gpd sent to the plant during summer months) and peak week reaches 44-percent of influent flows (80,000 gpd sent in fall). During the peak month and peak week discharges from industrial users, the industrial loading contributions increase. The anticipated average annual salinity concentrations (shown in **Table 8**) correspond to the historical concentrations identified in **Figures 10 and 11**.

As detailed in the project needs discussion (**Section 3.1.3**), the current permit limits effluent concentrations of 200 mg/L chloride, 250 mg/L sodium, and 1400 mg/L TDS. In the next permit renewal cycle, these limits are expected to be decreased to 150 mg/L chloride, 200 mg/L sodium, and 1200 mg/L TDS. The least cost solution is to reduce loading from the industrial dischargers. Based on the salinity balance presented above, a pretreatment program will bring the chloride, sodium, and TDS numbers closer to the discharge permit limits, but is unlikely to resolve the chloride issues entirely. This is further evident when looking at the WWTP historical violations (as detailed in **Appendix C**), which indicate the City has received fines for high chlorides prior to industrial discharger (Taylor Farms) connection to the sewer system (the industrial source connected in 2003 and fines date back to 2000). However, the industrial dischargers have certainly exasperated the salinity problems at the WWTP. The full extent of salt reduction will not be fully known until a pre-treatment program is implemented and additional samples are collected.

Taylor Farms is currently permitted to operate their own SBR treatment plant and discharge to their industrial spray fields under Waste Discharge Requirement (WDR) Order No. R3-2004-0066, but since 2003 they have sent flow the City's WWTP for treatment and disposal through the San Juan Bautista sewer collection system. As such, it is recommended to limit discharge into the collection system from Taylor Farms (and all industrial dischargers) to only municipal sewage (wash water and other industrial waste must be removed from the City's facilities and handled by the industry). Alternatively, the City may elect to allow the user to discharge wash water into the collection system after creating an industrial pre-treatment program that is approved by the City Council. Once the discharge limitations are enacted and the industrial dischargers are complying with the pre-treatment program, the City can establish a monitoring schedule to ensure the WWTP will remain compliant with the NPDES permit, along with implementing the below recommended upgrades.



3.0 NEED FOR PROJECT

3.1 HEALTH, SANITATION, AND SECURITY

Below are descriptions of the current regulatory compliance issues for the City's wastewater treatment facility.

3.1.1 Biological and Solids Management Project Needs

The San Juan Bautista WWTP currently operates under NPDES permit number CA0047902. The NPDES permit limits effluent concentration for BOD and TSS to 20 mg/L (average monthly concentration) and 60 mg/L (daily maximum concentration). In the past few years, the Regional Board has issued the City violation notices for BOD, ammonia, and suspended solids (as shown in **Figure 14** and documented in **Appendix C**). Based on the existing wastewater influent loading and the original design criteria of the WWTP, the secondary treatment facilities are undersized (design capacity is lower than current loading rates, as shown in **Tables 5 and 6**) and need to be modified to ensure continued compliance with nutrient removal.

Further, the plastic partition wall between the sludge storage lagoon (Ponds 2B and 2C) and the polishing pond (Pond 2A) is not sealed, allowing sludge to leach into the secondary effluent. Due to this inadvertent mixing of sludge and secondary effluent, the plant is at risk for continued discharge violations. For long term compliance, the sludge storage ponds need to be completely separated from the process flow stream.

3.1.2 Tertiary Treatment and Disinfection Project Needs

The permitted effluent limitation for total coliform is 23 MPN/100mL (five-day median concentration) and 2300 MPN/100mL (daily maximum concentration). Recently, there were several exceedances of both daily and five-day median total coliform and the Regional Board issued violation notices and fines (as shown in **Figure 15 and 16** and documented in **Appendix C**). Based on the existing wastewater influent flow rates and the original design criteria of the WWTP (shown in **Tables 5 and 6**), the tertiary facilities are undersized, as discussed herein.

The tertiary treatment facility is only designed to handle 0.2 Mgal/d, which is 80,000 gpd less than the existing average day maximum month flow rate ($0.28 - 0.20 = 0.08$ Mgal/d = 80,000 gpd). While there is some buffering capacity available in the SBR (the entire pond volume is only 1.6M gallons), the available volume is not enough to equalize the excess daily flow for an entire month (totaling 2.4M gallons of excess wastewater in one month). For long term compliance, the tertiary treatment and disinfection train needs to be expanded to accommodate higher flow rates (equalizing to annual average flows is not cost effective) or re-validate the existing facilities to higher flow rates than indicated in the design criteria (i.e. by increasing filtration rates to 5 gpm/sf and increasing UV dose rate or reducing turbidity).



3.1.3 Salinity Control Project Needs

When salinity is referenced herein (as with other engineering and scientific documents), it is often interchangeable with total dissolved solids (TDS) or electrical conductivity (EC) and includes nonionic substances (like silica) and ionic substances (like chloride, sodium, calcium, magnesium, sulfate, and nitrates). Salinity is transported with water and, as such, salt that originates in one location may be carried downstream to another. Significant problems ensue when the receiving water basin has no reliable way of disposing of salt. Increased levels of salinity can accelerate corrosion in plumbing, become toxic to aquatic life, and (most notably) negatively impact crop production.

California is one of the most productive agricultural areas on Earth. However, a downside of intensive irrigated agriculture is that it concentrates salt (both naturally occurring and added by agriculture as fertilizers and processing facilities) in residual water. The problem of salt accumulation in residual water has been recognized for decades, but potential remedies are expensive, which contributes to the ever-increasing problem of salt accumulation in the Central Coast.

In an effort to control the salt accumulation problem and ultimately stabilize it, and possibly reverse it (to some extent), the Regional Water Quality Control Board developed a salinity control plan that is incorporated into the 2016 Basin Plan and further disseminated such requirements to local municipalities within their NDPES discharge permits.

The San Juan Bautista WWTP currently operates under NPDES permit number CA0047902. Amongst other effluent limitations, the average monthly discharge limits for chloride, sodium, and total dissolved solids (TDS) are 200 mg/L, 250 mg/L, and 1400 mg/L, respectively. Based on conversations with the Regional Board and the 2016 Basin Plan, the salinity limits are expected to decrease in the next permit renewal cycle and is assumed to be similar to limits enforced in the City of Hollister's WWTP NPDES permit (150, 200, and 1200 mg/L, respectively).

As described previously, and shown in **Figure 13**, the City is currently in violation of chlorides, sodium, and TDS effluent limits and has received multiple violation notices and fines from the Regional Board for these effluent exceedance events (as documented in **Appendix C**). Further, the existing treatment facilities are not designed to remove salinity from the wastewater stream. In order to ensure long-term compliance with salinity limitations, the City will need to either implement source control measures (industrial pre-treatment programs and potentially lowering potable water hardness and associated self-regenerating water softener use) or provide additional treatment facilities to remove salinity from the wastewater.

Based on the average salinity concentrations entering the plant and the anticipated new permit limits, as shown in **Table 5** and described herein, the new salinity control measures need to be capable of removing at least 450 mg/L chloride, and 100 mg/L sodium, and 600 mg/L TDS.



3.2 AGING INFRASTRUCTURE

The original wastewater treatment plant was a facultative pond plant. The last major improvements project, in 2010, upgraded Pond 1 to an aerated pond that functions as sequencing batch reactors (SBR) and split Pond 2 into three cells (Cell A, B, and C). However, the 2010 project did not upgrade the liner in either Pond 1 or Pond 2. The liners have met their useful life and need to be replaced. The existing influent auto sampler does not function properly, providing unreliable composite samples, and has reached the end of life and should be replaced.

3.3 REASONABLE GROWTH

The planning period used for the project is 20 years. This allows for an appropriate timeline accommodating a limited amount of population growth (1.5%) in accordance with the City's planning horizons and roughly matches industry standards for the useful life of treatment works.

The current ADWF is approximately 0.18 Mgal/d and the treatment plant capacity is 0.27 Mgal/d. This leaves some unused treatment plant capacity that can be used to accommodate growth, some of which is already reserved. As stated previously, the WWTP should be improved in phased increments (Existing, Phase 1- near term growth, Phase 2- buildout capacity) and future users will have to fund the future capacity.

- Current: During the interim phase, the existing WWTP will continue to be used to provide treatment to the existing 908 sewer connections. This includes ongoing maintenance and repairs at the existing plant and implementation of an industrial pre-treatment program, but does not provide upgrades to the infrastructure to ensure long-term compliance with NPDES permits.
- Phase 1: The Phase 1 Project will upgrade the existing WWTP (including potential source water control) to accommodate 1.5% annual growth within current plant capacity. Upgrades to the existing facilities will ensure compliance with existing and anticipated future permits. The Phase 1 Project is described in the below detailed evaluation.
- Phase 2: The Phase 2 Project will expand the WWTP facilities to serve additional users, to accommodate "build out" conditions based on the City's Master Plan. The Phase 2 Project is not considered herein and is mentioned for long-term planning purposes only.



4.0 WWTP UPGRADE ALTERNATIVES CONSIDERED

The purpose of this report is to investigate alternatives and develop a recommended program for bringing the wastewater treatment plant into compliance with regulatory requirements. The alternative projects considered herein include the following:

1. Alternative 1, On-Site WWTP Upgrades and Off-Site Salinity Control: Provide source control in order to reduce the wastewater influent salinity concentrations to permissible levels. This project will allow the existing WWTP to remain operational with upgrades to the existing process facilities. All off-site salinity control options will also include the implementation of an industrial pre-treatment program for agricultural processing facilities (to limit salt discharge from those users).
 - A. Off-site salinity control will be accomplished by replacing well water (very hard water) with treated surface water (moderately hard) and remove self-regenerating water softeners in order to reduce the wastewater influent salinity concentrations to permissible levels (as detailed in Appendix A.1).
2. Alternative 2, On-Site WWTP Upgrades and On-Site Salinity Control: This project will replace the existing WWTP sequencing batch reactor (SBR) treatment system with a new membrane bioreactor (MBR), and reverse osmosis (RO) treatment or Electrodialysis Reversal (EDR) facilities that will remove salinity.
3. Alternative 3, Regionalization with Hollister WWTP and Off-Site Salinity Control: Provide source control in order to reduce the wastewater influent salinity concentrations and then pump the influent wastewater to a neighboring community (the City of Hollister WWTP). This project will replace the existing WWTP with an equalization basin and emergency storage pond to service a new pump station and pipeline to the Hollister WWTP for off-site treatment and disposal. All off-site salinity control options will also include the implementation of an industrial pre-treatment program for agricultural processing facilities (to limit salt discharge from those users).
 - A. Off-site salinity control will be accomplished by replacing well water (very hard water) with treated surface water (moderately hard) and remove self-regenerating water softeners in order to reduce the wastewater influent salinity concentrations to permissible levels (as detailed in Appendix A.1).

Based on the average salinity concentrations entering the plant and the assumed effluent limits in the new permit, as shown in **Table 5** and described in **Section 3.1.2**, the new facilities (industrial pre-treatment program and source control options) need to be capable of removing at least 600 mg/L TDS, 450 mg/L chloride, and 100 mg/L sodium. It is assumed that, once implemented, the industrial pre-treatment program will remove at least 562 mg/L TDS, 196 mg/L chloride, and 143 mg/L sodium (with a presumed sewer discharge limit of 4,000 gpd average flow rate and 885 mg/L TDS, 110 mg/L chloride, and 80 mg/L sodium, which is considered 15% higher than the average municipal wastewater



SAN JUAN BAUTISTA, WASTEWATER TREATMENT IMPROVEMENTS PROJECT

concentrations). As such, the source control measures may require an additional 205 mg/L chloride, 0 mg/L sodium, and 38 mg/L TDS removal.

The extent of industrial based salt reduction will not be fully known until an industrial pre-treatment program is implemented and additional samples are collected (the preliminary numbers presented herein are based on two weeks of composite samples from industrial dischargers). Once the pre-treatment program is adopted and frequent representative samples are analyzed, the remaining salinity removal needed to comply with the NPDES permit will be better quantified. For the purposes of this analysis, it is assumed that each source control option will provide sufficient salinity reduction, in combination with the pre-treatment program, to achieve compliance with the permit.

Note that Alternatives 1 and 3 both require the agricultural processing facility to have an industrial pre-treatment program (reducing the allowable salinity discharged into the sewers) and incorporating potable water source control in order to reduce wastewater influent salinity concentrations to permissible levels (i.e. providing soft water to the community and eliminating self-regenerating water softeners that dump high levels of chloride, sodium, and TDS into the sewers). The source control options were investigated in a separate report (see Appendix A.1) that will be considered herein for its life cycle costs and impacts on the associated alternative.



4.1 ALTERNATIVE DESCRIPTIONS AND COST ESTIMATES

Alternatives 1 through 3 are described herein.

4.1.1 Alternative 1, On-Site WWTP Upgrades and Off-Site Salinity Control

Off-site source control options were evaluated in **Appendix A.1** and the resulting best option is described as follows:

To reduce wastewater salinity and provide water security to the City of San Juan Bautista, a new regional potable water connection will be installed that supplies water from the West Hills WTP to the City’s distribution system. This project includes installation of a new 12-inch diameter pipe that will be constructed in a 6.0-mile long alignment (between the City of Hollister and the City of San Juan Bautista). After the West Hills WTP water source is installed, the City will need to implement a buy-back program to remove domestic water softeners from homes. Depending on the community, the rebate may cost between \$300 to \$800 per unit (\$105,000 to \$280,000- using cash payments and credits on sewer bills). The total life cycle cost for this option is \$9.2 million, as shown in **Table 9**. The water improvements will be used in conjunction with the pre-treatment program (reducing industrial discharge loading) to comply with the NPDES permit.

Table 9 West Hills WTP Life Cycle Costs

Description	Cost
Construction Costs	\$5,200,000
Engineering/CM Costs (25%)	\$1,300,000
Annual O&M ¹	\$168,000
Present Worth O&M, 20-years @ 3%	\$2,500,000
Domestic Softener Buyback	\$193,000
Total Life Cycle Cost	\$9,193,000

1. Based on \$1500/acre-feet (West Hills wholesale fee schedule), purchasing 0.2 MGD, & saving \$168,000/yr in existing water system operating costs (by not running/maintaining the wells as frequently).

WWTP Upgrades

Because the SBR pond is undersized (existing influent loading is already higher than the design criteria for the secondary treatment process) and the liner has reached its useful life expectancy, the SBR pond will be decommissioned and converted into an equalization basin (aerators will remain in place to reduce odors and provide mixing). The SBR will be replaced with a membrane bioreactor (MBR) facility, to ensure continued compliance with the permit (typically an SBR facility costs 5% more than a packaged MBR facility, but have additional benefits described herein). MBRs are considered the most robust and reliable treatment system available. MBRs provide a higher level of treatment than any other system, which is helpful in meeting both existing and anticipated future discharge requirements.



Further, MBRs have the smallest footprint and are easy to expand. Additionally, an MBR facility can act as a pre-treatment process if additional on-site salinity control is needed in the future (as it produces high quality effluent that is suitable for treatment in a reverse osmosis or electro dialysis reversal).

MBR Process Description

An MBR is a suspended growth biological treatment system like conventional activated sludge. However, in the MBR, the effluent clarification stage is replaced by a membrane filtration system. Membrane filtration units are typically placed inside basins that are specifically designed and located for this use (membrane basins). Treated wastewater effluent is drawn through the membranes, leaving activated sludge solids behind. The membranes provide such a high level of solids removal that the effluent from the MBR does not need further filtration through sand filters, such as required with conventional activated sludge. This is also helpful for the City because the existing sand filters are undersized (they are designed to accommodate only 0.2 Mgal/d and there is insufficient equalization capacity to reduce existing flows that low during peak month flow condition).

In fact, MBR effluent is superior to the effluent of a conventional activated sludge system with sand filters, having a typical effluent turbidity less than 0.2 NTU, compared to 2 NTU for the conventional system. The low turbidity is highly reliable because the membranes provide an absolute barrier to solids larger than the pore size of the membranes. This will be beneficial to the City because the existing UV disinfection system is sized to accommodate 0.2 Mgal/d, assuming 2 NTU filter effluent. With better quality effluent from the MBR, it is anticipated that the disinfection system can be re-rated to accommodate higher flows.

Because an MBR system does not require solids to settle in clarifiers (or the clarification stage of the SBR process pond), mixed liquor solids concentrations can be typically about three times as high as those in a conventional activated sludge system, making the footprint much smaller than an SBR. Further, because the clarification stage of the SBR and the tertiary filters are not needed, the MBR system will have a much smaller footprint than a conventional system. The waste activated sludge will be sent to a sludge storage tank and dewatering screw press for solids handling.

MBR systems require screens with openings of 1 to 3 mm, depending on the specific manufacturer, compared to 6 mm openings on the existing influent screen. Therefore, for the MBR alternative, new screens are required. See **Figure 18** for an MBR process flow schematic.



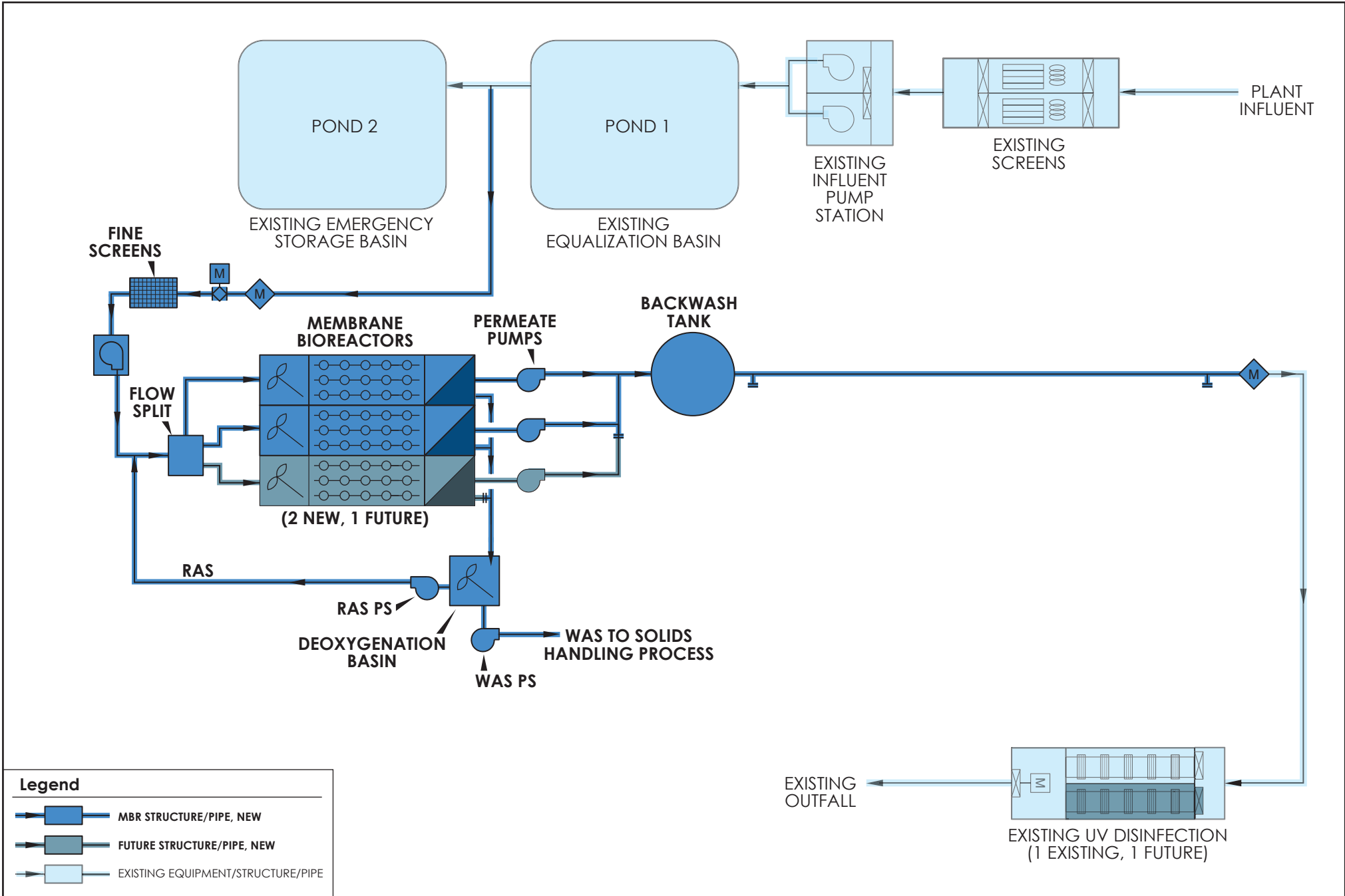

Figure 18
MBR Process Flow Diagram

MBR Design Criteria

There are now a significant number of MBR manufacturers with many installations worldwide that could supply a system to meet the requirements at San Juan Bautista. The membrane filtration systems of these various manufacturers are substantially different from each other and require different structural and equipment layouts. Therefore, it is typical to have a separate bid process, evaluation, and selection of the MBR equipment prior to proceeding with detail design of the project. For this report, proposals were received from two of the leading manufacturers (Suez and Ovivo). The analysis and costs presented herein are believed to be generally applicable to both of these manufactures, as well as others. The design criteria for the MBR system are listed in **Table 10**.

Table 10 MBR Design Criteria

Parameter	Value
Flow Rate, Mgal/d	
Average Day	0.27
Peak Month ¹	0.43
Influent Loading	
BOD average annual load, lb/d	628
BOD Max Month Load, lb/d	879
TSS average annual load, lb/d	691
TSS Max Month Load, lb/d	967
Mixed Liquor Suspended Solids (MLSS), mg/L	
Aeration and Anoxic Basin	8,000
Membrane Basin	10,000
Minimum Monthly Average Process Temperature, °C	10

1. Flow rates higher than peak month will be equalized

Future Salinity Control with MBRs

Unlike the existing sand media filtration system, an MBR system can function as a pre-treatment process step for reverse osmosis (RO) treatment. A small RO unit can be installed on the MBR effluent to remove just the amount of salt needed to comply with whatever regulation necessitates salinity removal. Although RO treatment is not needed for this alternative, as source control measures will reduce salt loading to the permitted levels, mechanical removal at the treatment plant may become necessary if further salinity removal is required in future permit cycles (beyond the anticipated effluent limits of 150 mg/L chloride, 200 mg/L sodium, and 1200 mg/L TDS).



MBR Life Cycle Costs

The life cycle costs for the MBR plant are presented in **Table 11**.

Table 11 MBR Process Life Cycle Costs

Description	Cost
Construction Costs	\$7,300,000
Engineering/CM Costs (25%)	\$1,825,000
Annual O&M ¹	\$73,800
Present Worth O&M, 20-years @ 3%	\$1,100,000
Total Life Cycle Cost	\$10,225,000

1. Based on mixing and aeration power, permeate pump and air scour power, membrane cleaning chemicals and membrane replacement costs.

Total Life Cycle Costs for Alternative 1

Because Alternative 1 requires off-site salinity control in order to reduce the wastewater influent salinity concentrations to permissible levels, the costs for source control must be incorporated into the MBR costs to get the total project cost. The source control can be used in conjunction with the pre-treatment program and are evaluated in case the pretreatment program (reducing industrial discharge loading) does not remove enough salinity from the influent wastewater stream to fully comply with the NPDES permit.

Table 12 Alternative 1 Life Cycle Costs

Description	Cost
MBR Construction Costs	\$7,300,000
Off-Site Salinity Control Costs	\$5,200,000
Engineering/CM Costs (25%)	\$3,125,000
Annual Source Water O&M	\$168,000
Annual MBR O&M ¹	\$73,800
Present Worth O&M, 20-years @ 3%	\$3,600,000
Domestic Softener Buyback	\$193,000
Total Life Cycle Cost	\$19,418,000



4.1.2 Alternative 2, On-Site WWTP Upgrades and On-Site Salinity Control

Similar to Alternative 1, the option for on-site salinity control includes an MBR facility (for biological control and as a pre-treatment train for the reverse osmosis, RO, system), but does not require the off-site West Hills WTP source control to be implemented. While the West Hills WTP connection will not be required (to reduce salinity) connection to the Batebel Road Well is required (for water security needs), as defined in Appendix A.1. The costs associated with connecting to the Batebel Road Well (detailed in Appendix A.1) is included in the construction costs for this alternative. The costs developed for the MBR facility will be carried forward from the previous section. The purpose of this section is to analyze the RO design and cost parameters and assess the viability of a side-stream RO treatment system, as depicted in **Figure 19**.

Reverse Osmosis Process Description

Reverse osmosis is the reversal of the natural osmotic process, accomplished by applying pressure in excess of the osmotic pressure to the more concentrated solution. This pressure forces the water through the membrane against the natural osmotic gradient, thereby increasingly concentrating the water on one side (i.e., the feed) of the membrane and increasing the volume of water with a lower concentration of dissolved solids on the opposite side (i.e., the filtrate or permeate). The required operating pressure varies depending on the total dissolved solids (TDS) in the feed water (i.e., osmotic potential), as well as on membrane properties and temperature.

For San Juan Bautista, only part of the MBR effluent needs to pass through the RO process in order to reduce salinity to permissible levels. This would eliminate almost all salinity in the RO-treated portion of the flow, such that when this side-stream flow is re-combined with the remainder of the plant flow, the overall TDS, chlorides, and sodium levels would be met.

RO membranes are not designed to remove suspended solids; therefore, the main objective of the treatment facilities upstream of the RO is to minimize the amount of suspended solids loading reaching the RO system. Further, the ionic and organic constituents play a major role in determining the overall water recovery and the necessity for chemical treatment requirements (such as pH adjustment and/or scale prevention). Fouling of RO membranes usually occur due to one of the following factors:

- Suspended solids in the feedwater
- Scale formation of metals
- Precipitation of low solubility salts
- Adsorption of organic materials on the membrane surface and biofouling (organic growth)

Suspended solids will be reduced to allowable levels as it passes through the MBR treatment process (silt density index, SDI, of three will be achieved, and SDI less than five is needed to meet RO warranty requirements). Due to hardness in the City's water, anti-scalant chemicals must be added continuously to the RO influent in order to control scale formation. To prevent precipitation of salts, acid may be required (depending on the Langlier Saturation Index, LSI, at the plant. LSI must remain below 2.5). In order to



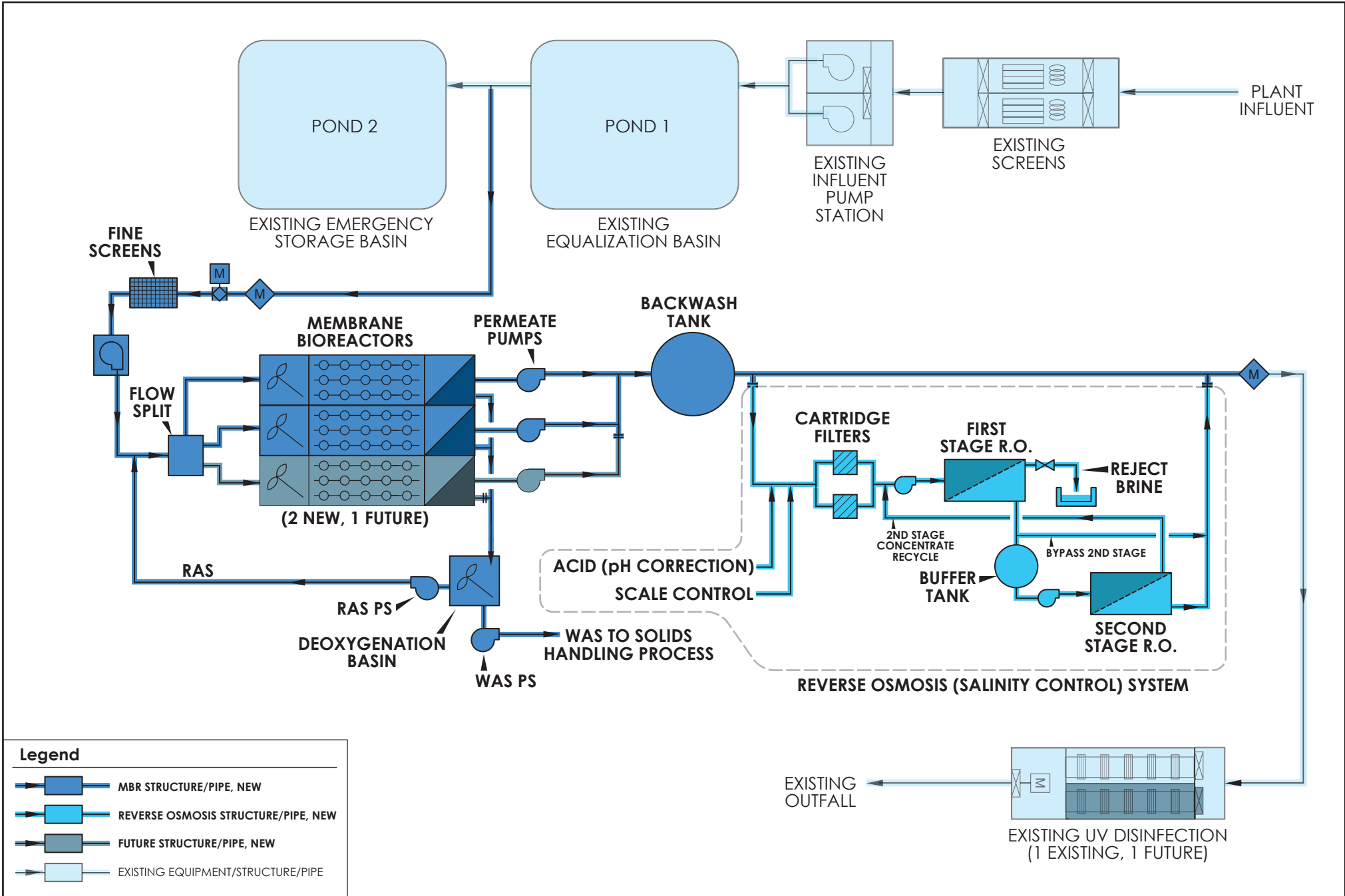

Figure 19
MBR Plus Reverse Osmosis Process Flow Diagram

A two stage RO configuration is recommended for high water recovery (80% overall) is proposed. The reject stream from the first stream becomes the feed water from the second stage, as shown in **Figure 21**. In contrast to MBRs, there are no backwash mechanisms for RO systems, but they do require chemical cleaning.

The RO membranes are a spiral-wound module with a sandwich arrangement of flat membrane sheets (called a “leaf”) wound around a central perforated tube. One leaf consists of two membrane sheets placed back to back and separated by a fabric spacer called a permeate carrier. The layers of the leaf are glued along three edges, while the unglued edge is sealed around the perforated central tube. A layer of plastic mesh called a spacer that serves as the feed water channel separates each leaf. Feed water enters the spacer channels at the end of the spiral-wound element in a path parallel to the central tube. As the feed water flows across the membrane surface through the spacers, a portion permeates through either of the two surrounding membrane layers and into the permeate carrier, leaving behind any dissolved and particulate contaminants that are rejected by the semi-permeable membrane. The filtered water in the permeate carrier travels spirally inward around the element toward the central collector tube, while the water in the feed spacer that does not permeate through the membrane layer continues to flow across the membrane surface, becoming increasingly concentrated in rejected contaminants. This concentrate stream exits the membrane element parallel to the central tube through the opposite end from which the feed water entered. A diagram of the spiral-wound element is shown in **Figure 22**.

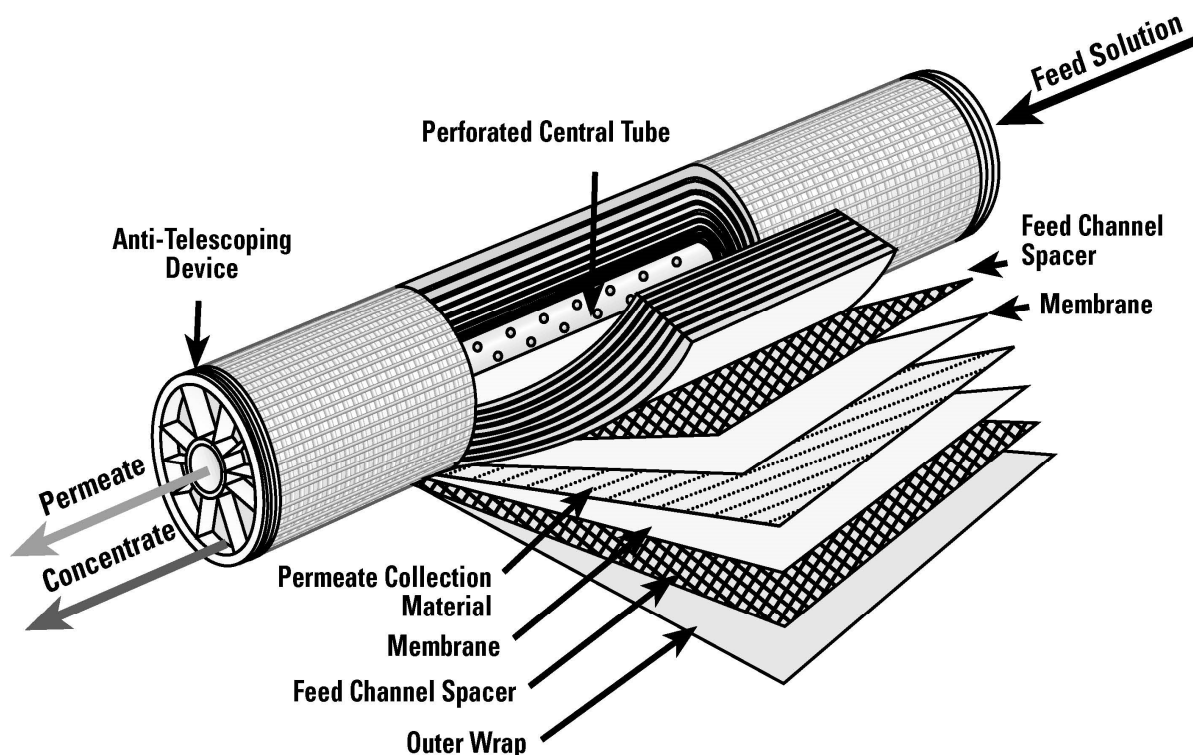

Figure 20 – Spiral-Wound RO Membrane Element Diagram



Reverse Osmosis Concentrate Management

Concentrate generated from the RO side-stream treatment process contains high amounts of TDS, chlorides, and organic compounds that are rejected by the RO membranes. Management of the reject brine solution (RO concentrate), which is typically 15% of the feed flow, poses the greatest challenge and costs for inland communities, such as San Juan Bautista.

Because ocean discharge and (presumably) deep well injection disposal options are not available, the City will need to figure out a way to manage the large volume of water rejected from the RO system. There are mechanical means to further concentrate the brine solution (such as vibratory shear enhanced processing, VSEP), which reduces the brine volume by 90%. After reducing the volume, the remaining highly concentrated brine will be stored throughout the winter season and dried in the summer before being hauled off-site for disposal (100-year water balance requires 6 acres of storage/drying and disposing in Buena Vista Landfill or John Smith Landfill). The cost of the brine management is included in the life cycle costs below.

MBR/RO Design Criteria

The MBR treatment design will be identical to the processes described in Alternative 1, with design criteria listed in Table 10. The sizing of the RO system is dependent on the targeted reduction in salinity, which may change before final design decisions are made (depending on the effectiveness of the industrial pre-treatment program). The design criteria for the side-stream RO system are listed in **Table 13**.

Table 13 Reverse Osmosis Design Criteria

Parameter	Value
Side-Stream Flow Rate,	
To RO, Mgal/d	0.43
RO Reject (flow to VSEP), gpm	60
VSEP Reject flow, gpm	6
From RO (Permeate), Mgal/d	0.34
Influent Concentrations, mg/L	
TDS	1800
Chlorides	600
Sodium	300



Table 13 Reverse Osmosis Design Criteria (Continued)

Parameter	Value
Effluent (Permeate) Concentrations, mg/L	
TDS	10.9
Chlorides	3.9
Sodium	2.3
Blended Concentrations, TDS, Chlorides, Sodium; mg/L	325,130,73

1. Flow rates higher than peak month will be equalized

Life Cycle Costs for Alternative 2

Because Alternative 2 requires MBR treatment to remove suspended solids and organic concentrations prior to entering the RO system, the MBR costs developed in Alternative 1 are included herein. The costs for RO side-stream treatment and brine concentration (VSEP) is also provided, see **Table 14** for the total life cycle costs associated with Alternative 2.

Table 14 Alternative 2 Life Cycle Costs

Description	Cost
MBR Construction Costs	\$7,300,000
RO Construction Costs	\$4,800,000
Engineering/CM Costs (25%)	\$3,025,000
Annual MBR O&M	\$73,800
Annual RO and VSEP O&M ²	\$74,400
Annual Brine Removal O&M ³	\$46,600
Present Worth O&M, 20-years @ 3%	\$2,900,000
Domestic Softener Buyback	--
Total Life Cycle Cost⁴	\$18,025,000

1. Including cost to purchase 6-acres for brine storage/drying at \$85,000 per acre.
2. Based on chemical cleaning, booster pump electricity, and RO membrane replacement
3. Assumed hauling costs of \$50/ton, dried to 50-percent concentration
4. The City will need to invest in the Betable Well development, to provide water reliability, adding an additional \$5.7M to the total cost of this project (making the total life cycle costs \$23.7M).



4.1.3 Alternative 3, Off-Site Salinity Source Control and Regionalization with Hollister WWTP

In order to send wastewater to Hollister WWTP, the off-site source control measures must be enacted, and salinity must be within Hollister’s effluent limits. As such, the costs developed for the source control options, detailed in Appendix A.1 and documented in Alternative 1, will be carried though here. The source control measures can be used in conjunction with the pre-treatment program and are evaluated in case the pretreatment program (reducing industrial discharge loading) does not remove enough salinity from the influent wastewater stream to fully comply with the NPDES permit. The purpose of this section is to analyze regionalization with Hollister WWTP and the costs associated with pumping wastewater off-site for treatment and disposal, as depicted in **Figure 21**.

Regionalization Process Description

In order to send flow to the City of Hollister WWTP, the San Juan Bautista WWTP will be decommissioned and the ponds converted into equalization and emergency storage basins (aerators will remain in place to reduce odors and provide mixing). All screened raw sewage, up to the peak daily flow rates, will be pumped to Hollister in an 8-inch pipeline. The remaining flow will be diverted to a lined equalization pond (Pond 1) and overflow into an emergency storage basin (Pond 2). The pump station will be a trench style, self-cleaning, submersible pump station with centrifugal pumps. The facility will include a surge tank and pig launching station. The pipe alignment will include pig launching and receiving stations, to ensure the pipe can be properly maintained and cleaned.

Regionalization Design Criteria

The design criteria for the regional needs are listed in **Table 15**.

Table 15 Regionalization Design Criteria

Parameter	Value
Pump Station	
Capacity, gpm	550
Head, psi	105
Power Demands, HP	50
Number of Pumps	3 (1 duty, 1 standby, 1 future)
Surge Tank Size, gallons	10,000
Lined Equalization Basin Size, MG	1.6
Emergency Storage Basin Size, MG	4.3
Pipeline Dimeter (inch) & Length (miles)	8 & 6.5



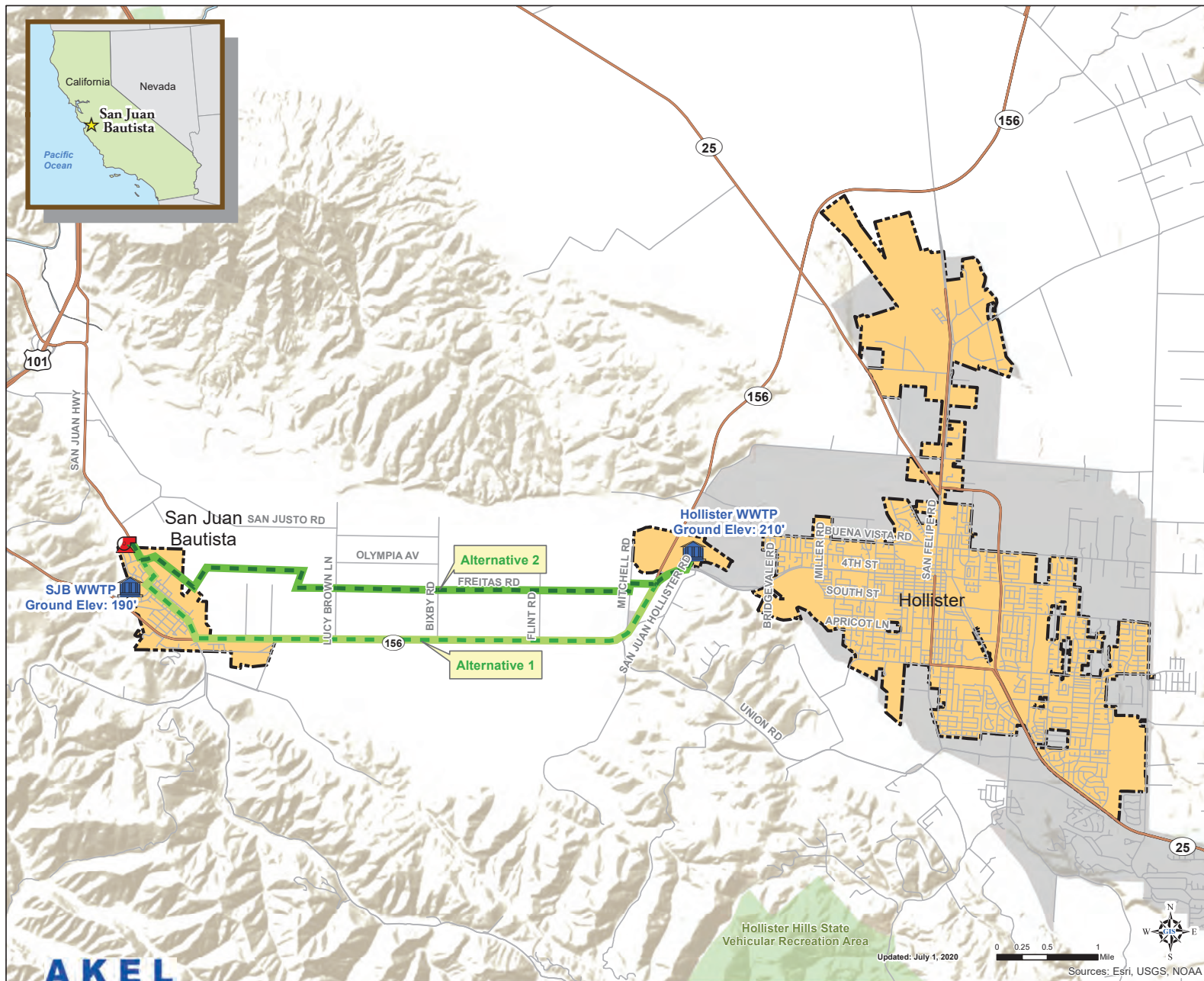

- Legend**
- Potential Lift Station
 - Alternative Connection Alignments
 - Major Highways
 - City Limits
 - Urbanized Area
 - Protected Open Space
 - Rivers/Streams
 - Waterbodies

PRELIMINARY

**Figure 21
Regional Connection
Alternatives**
Wastewater System Master Plan
City of San Juan Bautista



Updated: July 1, 2020
Sources: Esri, USGS, NOAA
File Path: P:\GIS\GIS_P\Projects\San_Juan_Bautista\Sewer\191112.MPS\JB_Fig74_SewerRCA_070120.mxd



Benefits of Regionalization

The California State Water Resources Control Board developed twelve general principles (adopted in 1972) for water quality control, which have been incorporated into the Water Quality Control Plan (Central Coast Basin Plan). Two of the principles specifically encourage regional (centralized) solutions, as quoted below:

- “Coordinated management of water supplies and wastewaters on a regional basis must be promoted to achieve efficient utilization of water”
- “Wastewater collection and treatment facilities must be consolidated in all cases where feasible and desirable to implement sound water quality management programs based upon long-range economic and water quality benefits to an entire basin.”

Some Regional Boards have even passed resolutions (similar to the Central Valley Resolution No. R5-2009-0028), that requires the Regional Water Board to facilitate opportunities for regionalization and consider innovative permitting options when existing NPDES permit requirements, waste discharge requirements, and/or enforcement Orders inhibit the ability to implement regionalization. Similarly, in recent meetings with the Central Coast Regional Board, Board staff are encouraging regionalization for the City of San Juan Bautista.

There are a number of potential benefits to regionalization including the following:

1. Coordinated management of water supplies and wastewaters on a regional basis promotes efficient utilization of water.
2. Reducing discharges of wastewater into seasonal or ephemeral streams (such as the drainage channel adjacent to the facility) decreases habitat changes to the waterbodies that occur when flow is not naturally present in the streams.
3. The costs of constructing, expanding, upgrading, and maintaining wastewater treatment systems are large, and can be a severe impact on small communities. Increased rates on most communities, but especially for the small communities in particular, result in the likelihood of a successful Proposition 218 challenge to rate increases. Although the capital investment for regionalization may result in a higher initial cost (compared to upgrading an existing facility to meet current regulatory requirements), the costs associated with meeting future regulatory requirements can be spread over a larger population and ultimately reduce the per capita costs of wastewater treatment and disposal. Regionalization also increases the technical and economic feasibility of a higher level of wastewater treatment, allowing the treated water to become a resource.



Life Cycle Costs for Alternative 3

Because Alternative 3 requires off-site salinity control in order to reduce the wastewater influent salinity concentrations to permissible levels, the costs for source control must be incorporated into the pump station and pipeline costs to get the total project cost, as shown in **Table 16**. The source control can be used in conjunction with the pre-treatment program and are evaluated in case the pretreatment program (reducing industrial discharge loading) does not remove enough salinity from the influent wastewater stream to fully comply with the NPDES permit.

Table 16 Alternative 3 Life Cycle Costs

Description	Cost
Regional Construction Costs	\$6,270,000
Hollister Connection Fees ¹	\$4,670,000
Off-Site Salinity Control Costs	\$5,200,000
Engineering/CM Costs (25%)	\$2,870,000
Annual Source Water O&M	\$168,000
Annual Regional Pumping O&M ¹	\$238,000
Present Worth O&M, 20-years @ 3%	\$6,050,000
Domestic Softener Buyback	\$193,000
Total Life Cycle Cost	\$25,253,000

1. City of Hollister connection fee calculated at \$27.9/gpd and \$4531.66/residential user.
2. Includes City of Hollister monthly service fee at \$8.7/HCF (minus the cost savings for decommissioning the SJB WWTP, assumed to be half the existing service fees), and new regional pump station power costs.

4.2 COMMON DESIGN CRITERIA

In order to develop a fair comparison of alternatives, it is important to establish common design criteria on which to base the evaluation. Key design parameters are discussed below:

- **Design Wastewater Flow:** The design criteria of the WWTP Improvements Project indicate that the design annual average influent flow rate and peak day max month flow rates are 0.27 and 0.43 Mgal/d, respectively.
- **Design Wastewater Loads:** The design criterial of the WWTP Improvements Project indicate that the average annual influent BOD load and peak month load are 628 lb/d and 879 lb/d, respectively. Further, the average annual influent TSS load and peak month load are 307 and 430 lb/d, respectively.



- **Design Salinity Loads:** The design criterion of the WWTP Improvements Project indicate that the average annual influent TDS, Chloride, and Sodium concentrations are 1800, 600, and 300 mg/L, without industrial pretreatment or source control.
- **Industrial Pre-Treatment Salinity Reduction:** It is assumed that, once implemented, the industrial pre-treatment program will remove at least 562 mg/L TDS, 196 mg/L chloride, and 143 mg/L sodium (with a presumed sewer discharge limit of 4,000 gpd average flow rate for municipal wastewater only and 885 mg/L TDS, 110 mg/L chloride, and 80 mg/L sodium, which is considered 15% higher than the average municipal wastewater concentrations). As such, the source control measures may require an additional 205 mg/L chloride, 0 mg/L sodium, and 38 mg/L TDS removal
 - The extent of industrial based salt reduction will not be fully known until a pre-treatment program is implemented and additional samples are collected (the preliminary numbers presented herein are based on a two-week sampling event from industrial dischargers). Once the pre-treatment program is adopted and frequent representative samples are analyzed, the remaining salinity removal needed to comply with the NPDES permit will be better quantified.
 - For the purposes of this analysis, it is assumed that each source control option will provide sufficient salinity reduction, in combination with the pre-treatment program, to achieve compliance with the permit.
- **Potable Water Reliability:** The City only has a firm capacity of 130 gpm using Well No. 1 as the primary source of water (when the higher production Well No. 5 is removed from service for routine maintenance or possible nitrate contamination). As such, the City needs a backup water source to ensure a viable water portfolio, which can be achieved by a new well (the Betable Road Well) or connecting to Hollister WTP. Costs associated with water reliability measures will be incorporated into all alternatives.
- **Cost Index, Interest Rate and Useful Lives:** The cost index used for the project cost estimates is based on the ENR Construction Cost Index at start of construction (CCI) of 11,000 (June 2020). The interest rate adjusted for inflation used in the life cycle analyses is 3.0% per year and the useful life of most of the project alternatives is estimated to be approximately 20 years to match the planning horizon (although structural components will last much longer, equipment will not).
- **Planning Period:** The planning period used for the project is 20 years. This allows for an appropriate timeline accommodating community service and a limited amount of growth in accordance with City planning horizons and roughly matches industry standards for the useful life of treatment works.
- **Contingency:** For the level of project development, all costs will be escalated by 30% contingency factor, to account for unknown project details.



SAN JUAN BAUTISTA, WASTEWATER TREATMENT IMPROVEMENTS PROJECT

The design parameters relevant to the development and analysis of the various project alternatives are summarized in **Table 17**.

Table 17 WWTP Improvement Project Design Criteria

Parameter	Unit	Phase 1 Condition ADWF = 0.27 Mgal/d
Flow		
Avg. Day Annual Flow (AAF)	Mgal/d	0.27
Average Day Max Month Flow (ADMMF)	Mgal/d	0.43
Peak Day Flow (PDF)	Mgal/d	0.80
Peak Hour Flow (PHF)	Mgal/d	1.08
Biological Oxygen Demand (BOD)		
Annual Average Load (AAL)	lb/d	628
Avg. Day Max Month Load (ADMML)	lb/d	879
Average Concentration	mg/L	279
Max Month Concentration	mg/L	390
Total Suspended Solids (TSS)		
Annual Average Load (AAL)	lb/d	691
Avg. Day Max Month Load (ADMML)	lb/d	967
Average Concentration	mg/L	307
Max Month Concentration	mg/L	430
TKN Concentration		
Annual Average Load (AAL)	lb/d	119
Avg. Day Max Month Load (ADMML)	lb/d	167
Average Concentration	mg/L	53
Max Month Concentration	mg/L	74
Total Dissolved Solids⁴	mg/L	790
Chloride⁴	mg/L	196
Sodium⁴	mg/L	111

1. If water conservation measures materialize, then the design organic load of the plant will be reached before the hydraulic design flow.
2. Average concentrations are calculated using AAF combined w/AAL
3. Average day max month load is calculated using AAF combined w/ADMML
4. After implementation of an industrial pre-treatment program and source control. To be confirmed with local limits study and additional samples.



4.3 POTENTIAL ENVIRONMENTAL IMPACTS OF PROJECT ALTERNATIVES

4.3.1 Alternative 1, On-Site WWTP Upgrades and Off-Site Salinity Control

The source water pipe alignment will be installed within previously disturbed areas, along the side of roadways (in the public utilities right-of-way) and the wastewater upgrades will be done at the treatment plant site (within the existing fence line). Environmental impacts are considered less than significant and, if selected, will be confirmed during the CEQA Initial Study and Mitigated Negative Declaration (IS/MND) phase.

4.3.2 Alternative 2, On-Site WWTP Upgrades and On-Site Salinity Control

The wastewater upgrades will be done at the treatment plant site (within the existing fence line). This option requires the acquisition of 6-acres of land and converting it into a brine storage and drying pond. Any new property purchased by the City will be carefully chosen to minimize environmental impacts. All other environmental impacts are considered less than significant and, if selected, will be confirmed during the CEQA Initial Study and Mitigated Negative Declaration (IS/MND) phase.

4.3.3 Alternative 3, Off-Site Salinity Source Control and Regionalization with Hollister WWTP

The source water pipe and wastewater pipe alignment will be installed within previously disturbed areas, along the side of roadways (in the public utilities right-of-way) and the wastewater decommissioning and conversion to a pump station will be done at the treatment plant site (within the existing fence line). Environmental impacts are considered less than significant and, if selected, will be confirmed during the CEQA Initial Study and Mitigated Negative Declaration (IS/MND) phase.

4.4 LAND REQUIREMENTS

The proposed Project components are all located in City owned property (within existing well sites or at the Wastewater Treatment Plant) or along existing roadways within the City's right-of-way in regional alignments and are within previously disturbed areas. Other than the Regional Alignments and the brine storage (for the RO option), the properties are currently owned by the City and does not require any additional acquisitions or lease of land. For any regional pipeline, the City will need to ensure they stay within the public utility right-of-way. If the City installs a RO (or EDR) system, they will need to purchase 6-acres of property to store and dry brine solution.

4.5 POTENTIAL CONSTRUCTION PROBLEMS

Construction of each alternative project is expected to be routine. However, potential construction problems could include keeping the existing treatment plant in operation during construction. The construction activities will also require temporary shutdowns of portions of the treatment plant though these are common for this type of project. Ingress/egress to the treatment plant must also be maintained throughout construction.



4.6 SUSTAINABILITY CONSIDERATIONS

4.6.1 Water and Energy Efficiency

The improvement project will include Title 24 compliance equipment, including premium efficiency motors. It will include upgraded instrumentation to optimize treatment performance, minimizing energy demands associated with aeration and mixing. All options will provide better water quality (effluent) that achieves water quality goals set by the Regional Board.

4.6.2 Other, California Priorities

The California state planning priorities identified in Government Code 65041.1 are intended to promote equity, strengthen the economy, protect the environment, and promote public health and safety in the State, including in urban, suburban, and rural communities. These priorities are described as follows:

- **Promoting infill development** and equity by rehabilitating, maintaining, and improving existing infrastructure that supports infill development and appropriate reuse and redevelopment of previously developed, underutilized land that is presently served by transit, streets, water, sewer, and other essential services, particularly in underserved areas, and to preserving cultural and historic resources.
- **Protecting environmental and agricultural resources** by protecting, preserving, and enhancing the state's most valuable natural resources, including working landscapes such as farm, range, and forest lands, natural lands such as wetlands, watersheds, wildlife habitats, and other wildlands, recreation lands such as parks, trails, greenbelts, and other open space, and landscapes with locally unique features and areas identified by the state as deserving special protection.
- **Encouraging efficient development** patterns by ensuring that any infrastructure associated with development, other than infill development, supports new development that does all of the following:
 - Uses land efficiently.
 - Is built adjacent to existing developed areas to the extent consistent with the priorities specified pursuant to subdivision.
 - Is located in an area appropriately planned for growth.
 - Is served by adequate transportation and other essential utilities and services.
 - Minimizes ongoing costs to taxpayers

The following bullets describe how the City will promote project alternatives that address each of the planning practices as defined in Section 65041.1 of the California Government Code and sustainable water resources management priorities.

- **Infill Development.** The City promotes infill development and equity by rehabilitating, maintaining, and improving existing infrastructure that supports infill development and appropriate reuse and redevelopment of previously developed, underutilized land that is presently served by water and sewer infrastructure, particularly in underserved areas, and to



preserving cultural and historic resources. Planning activities for this and prior plant upgrades have been limited to providing capacity for anticipated infill growth within the City. Growth outside the City or in excess of capacity planned to serve anticipated infill must be planned, designed and constructed by those private parties which will benefit from those improvements.

- **Environmental Resources.** The City protects, preserves, and enhances the state's most valuable natural resources, including forest lands, natural lands such as wetlands, watersheds, wildlife habitats, and other wildlands, recreation lands such as parks, trails and other open space, and landscapes with locally unique features and areas identified by the state as deserving special protection. They accomplish this by: optimizing the footprint of their facilities, keeping those to a minimum, thereby preserving nearby forested and grassland open spaces and wetlands; water quality is protected and enhanced by the operation of their treatment and disposal facilities which produce effluent which meets (other than identified herein) and in some cases exceeds established water quality objectives. Taken together these activities enhance the overall environmental quality within the watershed.
- **Efficient Development Patterns.** The City encourages efficient development patterns by ensuring that any infrastructure associated with development that is not infill supports new development, uses land efficiently, is built adjacent to existing developed areas to the extent possible and is placed in areas appropriately planned for growth, is served by adequate infrastructure and other essential utilities and services, and minimizes ongoing costs to taxpayers. Planning activities for this and prior plant upgrades have been limited to providing capacity for anticipated infill growth within the City. Growth outside the City or in excess of capacity planned to serve anticipated infill must be planned, designed and constructed by those private parties which will benefit from those improvements.
- **Water Resources Management.** The City encourages sustainable water resources management by ensuring that sustainable water resources measures are implemented, such as conserving water, conserving energy, and applying Low Impact Development Best Management Practices to the maximum extent practicable. Taken together with the above noted activities these enhance the overall environmental quality within the watershed.

4.7 COST ESTIMATES

See Section 5.1.

5.0 SELECTION OF AN ALTERNATIVE

5.1 LIFE CYCLE COST ANALYSIS

The life cycle cost estimates for Alternatives 1, 2, and 3 are summarized in **Table 18**.



Table 18 Alternative Options Life Cycle Costs Summary

Description	Alternative 1: On-Site WWTP Upgrades & Off- Site Source Control (MBR & West Hills WTP)	Alternative 2: On-Site WWTP Upgrades and On- Site Source Control (MBR+RO)	Alternative 3: Regionalization with Hollister WWTP & Off-Site Source Control (Hollister WWTP & West Hills WTP)
Source Control Costs (West Hills WTP, See Appendix A.1)			
Construction Costs ¹	\$5,200,000		\$5,200,000
Engineering/CM Costs ²	\$1,300,000		\$1,300,000
Present Worth O&M, 20-years @ 3% ³	\$2,500,000		\$2,500,000
Domestic Softener Buyback	\$193,000		\$193,000
Source Control, Total Life Cycle Cost	\$9,193,000		\$9,193,000
Water Security Costs (Betabel Road Well, See Appendix A.1)			
Construction/Engineering/CM Costs ⁴	---	\$5,010,000	---
Present Worth O&M, 20-years @ 3% ⁵	---	\$670,000	---
Water Security, Total Life Cycle Cost	---	\$5,680,000	---
WWTP Upgrade Costs			
Construction Costs	\$7,300,000	\$12,100,000 ⁶	\$10,940,000 ⁷
Engineering/CM Costs	\$1,825,000	\$3,025,000	\$1,570,000
Present Worth O&M, 20-years @ 3%	\$1,100,000	\$2,900,000 ⁸	\$3,550,000 ⁹
WWTP Upgrade, Total Life Cycle Cost	\$10,225,000	\$18,025,000	\$16,060,000
IMPROVEMENT PROJECT TOTAL LIFE CYCLE	\$19,418,000	\$23,705,000	\$25,253,000

1. Based on a 12-inch diameter pipe in a 6.0-mile long alignment (connecting to West Hills WTP)
2. Engineering/CM fees are estimated to be 25% of construction cost
3. Based on \$1500/acre-feet (West Hills wholesale fee schedule), purchasing 200,000 gpd, and saving \$168,000/yr in existing water system operating costs (by not running/maintaining the wells as frequently).
4. Based on a 12-inch diameter pipe in a 3.5-mile long alignment and cost of iron/manganese filter (connecting to Betabel Road Well)
5. Based on \$200/acre-feet, purchasing 200,000 gpd
6. Includes cost to purchase 6-acres for brine storage/drying (at \$85,000 per acre)
7. Includes City of Hollister connection fee calculated \$27.9/gpd and \$4531.66/residential user (totaling \$4.7M)
8. Includes brine hauling costs of \$50/ton, dried to 50-percent concentration
9. Includes City of Hollister monthly service fee at \$8.7/HCF (minus the cost savings for decommissioning the SJB WWTP, assumed to be half the existing service fees), and new regional pump station power costs
10. Construction costs based on ENR of 13,000



5.2 NON-MONETARY FACTORS

The Improvement Project options considered must be evaluated not only for their ability to meet NPDES discharge permit compliance, but also for their ranking against the other non-monetary factors. To compare the options, a list of criteria is developed by which the alternatives will be ranked. **Table 19** provides a list of criteria and a brief explanation why it is important in the evaluation process.

Table 19 Improvements Project Selection Criteria

Criterion	Description
Life Cycle Costs (Capital and O&M)	Cost to design new processes, purchase equipment and construct facilities. Including the cost to operate new facilities – such as power costs, chemical costs, periodic replacement costs, maintenance costs, etc.
Footprint	The amount of land area needed to physically house the new process facilities
Operational Simplicity	A measure of operator time required to operate and perform routine maintenance on equipment. It is expected that the fewer moving parts in the process, the less operator time will be needed to maintain the equipment
Reliability	A measure of how dependable and robust the system is and how well it will react to changing wastewater quantity and quality (flows and loads)
Future Regulations Compliance	Ability for new equipment to fit into existing processes and flexibility of process to meet future regulations

1. All options presented include added costs to implement water security measures (where applicable) and therefore this criterion was removed from the list.

The criteria themselves are given a score from one to five based their importance to the project. A score of five carries the highest level of relative importance while a score of one has a relatively lower level of importance. The value entered in the blue squares compares the criterion in the row to the criterion in the column for relative importance in the selection process. Each score entered in the blue squares will have a paired score in the white squares and the two paired scores will equal six. The relative weight of each criterion is calculated and ranked in the two columns on the right.

Table 20 provides a matrix assigning a score for each of the alternatives and its relative weight in determining the preliminary treatment process selected.



Table 20 Improvements Project Options Criteria Weight

	Life Cycle Costs (Capital and O&M)	Footprint	Ease of O&M	Reliability	Flexibility (Future Regulations)	Relative Weight
Life Cycle Costs (Capital and O&M)		5	2	3	2	12
Footprint	1		1	2	1	5
Operational Simplicity	4	5		3	2	14
Reliability	3	4	3		3	13
Future Regulations Compliance	4	5	4	3		16
Evaluation Criterion		Entered Score	Paired Score			
Substantially More Important		5	1			
Somewhat More Important		4	2			
Equal Importance		3	3			
Somewhat Less Important		2	4			
Substantially Less Important		1	5			

- Blue cells are scored using evaluation criterion (score 1-5) as it's compared to the top row criteria. White cells are the paired score (score 5-1). Relative weight is the total of the entire row and carried through to the selection matrix.

Table 21 presents a comparative score (with the total of the scores equal to exactly ten) for the three alternatives evaluated. This matrix also takes the relative weight determined in Table 20 for each of the evaluation criteria and multiplies that number by the comparative score for each of the criteria. This calculation returns a weighted score for each of the evaluation criteria and each of the alternative source control measures. The sums of these weighted scores for the seven evaluation criteria is presented as a total score on the bottom row. The higher the total score, the better the option for this application.



Table 21 Improvements Project Options Selection Matrix

Criteria	Relative Weight	Comparative Score (Score Total Must Equal 10)			Criterion Score (Relative Weight Times Comparative Score)		
		MBR & West Hills WTP	MBR/RO	Hollister WWTP & West Hills WTP	MBR & West Hills WTP	MBR/RO	Hollister WWTP & West Hills WTP
Life Cycle Costs (Capital and O&M)	12	3.6	3.3	3.1	43	40	37
Footprint	5	4.0	2.0	4.0	20	10	20
Operational Simplicity	14	3.0	2.0	5.0	42	28	70
Reliability	13	3.0	3.0	4.0	39	39	52
Future Regulations Compliance	16	3.0	3.0	4.0	48	48	64
TOTAL SCORE					192	165	243

Improvements Project Recommendation

As shown in **Table 21**, connecting to regional facilities including the Hollister WWTP (and separate source control measures with West Hills WTP connection, detailed in Appendix A.1) Alternative 3 scores the highest compared to the other options evaluated in the analysis and is therefore the recommended improvement project.



6.0 PROPOSED PROJECT, RECOMMENDED ALTERNATIVE

As shown in **Table 21**, connecting to regional facilities including the Hollister WWTP (and separate source control measures with West Hills WTP connection, detailed in Appendix A.1) Alternative 3 scores the highest compared to the other options evaluated in the analysis and is therefore the recommended improvement project.

6.1 PRELIMINARY PROJECT DESIGN DESCRIPTION

The Apparent Best Project includes decommissioning the existing SBR pond plant and converting it into an equalization basin (aerators will remain in place to reduce odors and provide mixing). A new pump station will be constructed to deliver equalized and screened raw sewage to the City of Hollister WWTP in an 8-inch diameter pipe (for treatment and disposal at the Hollister plant), as shown in **Figure 21**. A separate source control project will be constructed (as defined in Appendix A.1) to reduce hardness in the potable water system and associated salinity in the wastewater stream.

6.2 PROPOSED PROJECT SCHEDULE

Implementation of the project will follow the timeline required to secure funding and to complete the environmental CEQA and permitting process, establish user rates, complete the Proposition 218 process for those rates, and complete design and construction. An estimate of the timeline, subject to change, is presented in **Table 22**.

Table 22 Preliminary Project Schedule

Task	Completion Data
Preliminary Engineering Report	August 2020
Submit Construction Funding Application	August 2020
Implement Pre-Treatment Program	October 2020
Design & Project Management Consultant Selection	October 2020
Collect Samples at Industrial Discharge	April 2021
Design (pre-select MBR manufacturer)	May 2021
NEPA and CEQA permitting process	February 2022
Final Design (Drawings and Specifications)	March 2022
Bidding Process	May 2022
Construction NTP	June 2022
Construction Substantially Complete	July 2023
Final Startup, Testing, and Operations	November 2023



6.3 PERMIT REQUIREMENTS

As stated previously, the San Juan Bautista Wastewater Treatment Plant (WWTP) operates under Order No. R3-2009-0019 NPDES permit No. CA0047902. Based on the current permit, the average monthly discharge limits for chloride, sodium, and total dissolved solids (TDS) are 200 mg/L, 250 mg/L, and 1400 mg/L, respectively. The anticipated salinity balance, after the project is complete, is shown in **Table 23**. As detailed, the salinity concentrations are anticipated to be in compliance with the current permit once the project is complete (including limiting industrial users to only discharging municipal wastewater into the City's sewer collection system, procuring source water from West Hills WTP that is blended with the City's well water at 60-percent ratio, and implementing a water softener buy-back program that is expected to reduce half the domestic softener use). Future permit restrictions that decrease the salinity concentrations beyond the existing limits (presumed to be 150, 200, and 1200 mg/L, respectively) will need to be accommodated through additional water softener buy-back or higher blended ratios from West Hills WTP.

The design of the improvements will be in compliance with the latest building codes (2019 California Building Code, CBC), design and placement of structural concrete will conform to American Concrete Institute Code Requirements (ACI 318) and for liquid containing structures ACI 350. All drinking water improvements will be done in accordance with NSF 61 standards and comply with CCR Title 17, 22, and 40.

During construction, the General Contractor will be required to obtain an encroachment permit from the County of San Benito, an air permit from the Monterey Bay Air Resources District, and a General Permit for storm water discharges associated with construction (and SWPPP compliance) from the Regional Board.



Table 23 Future WWTP Influent Salinity Balance (Average Daily Loads)

Salt Contributors to Total WWTP Influent	TDS	Chloride	Sodium
SALINITY LOADING, lb/d			
Well No. 1 & West Hills Blend (Raw Water) ¹	615	118	87
Diet and Personal Care Products ²	400	27	19
Self-Regenerating Water Softeners ³	146	88	59
Industrial User ⁴	30	4	3
Inflow and Infiltration ⁵	0	60	0
TOTAL WWTP INFLUENT, lb/d	1,191	296	167
SALINITY CONCENTRATION, mg/L			
Well No. 1 (Raw Water) ¹	407	78	58
Diet and Personal Care Products ²	265	18	12
Self-Regenerating Water Softeners ³	97	58	39
Industrial User ⁴	20	2	2
Inflow and Infiltration ⁵	0	40	0
TOTAL WWTP INFLUENT, mg/L	789	196	111

1. Based on average well & West Hills WTP data shown in Tables 4 & 11 with a blended ratio of 40% well water and 60% surface water.
2. Dietary and Personal Care Products: TDS concentration of 265 mg/L based on Central Valley Clean Water Association “Salinity Management Practices for POTWs” 2012. Chloride and sodium concentrations based on “Chloride Contributions from Water Softeners and Other Domestic Sources” University of Minnesota 2019 and “Characterizing and Managing Salinity Loading in Reclaimed Water Systems” by AWWA & Thompson 2006.
3. Water softener efficiency based on 3300 grains hardness per pound NaCl (and average blended source water hardness of 228 mg/L CaCO₃) in accordance with historical and current California efficiency standards and half the influent flow rate is being treated by ion exchange water softeners. Calculation assumes 20% of households will still have water softeners after buyback program takes effect (approximately 175 softeners remaining).
4. Based on industrial pre-treatment limiting drains to only municipal wastewater flow from facility at 4,000 gpd average and salinity concentrations of 885 mg/L TDS, 110 mg/L chloride, and 80 mg/L sodium). To correlate these values to total wastewater influent flow concentration, the sample concentrations were multiplied by 2.2% (4,000 gpd ÷ 180,000gpd = 2.2%)
5. To account for missing salinity, inflow and infiltration (I/I) based loading (salinity from agricultural runoff and natural erosion/weathering of rock minerals) was calculated by taking the difference between historical influent loads (from Table 5) and total other loads contributors identified herein. The missing chloride concentration may also be linked to the historical changes in the primary source water, as various wells were placed online or taken offline (i.e. Well No. 1 has chloride concentrations that are 25 mg/L lower than Well No. 6, etc).

6.4 SUSTAINABILITY CONSIDERATIONS

In agreement with the State planning priorities of Government Code 65041.1 and sustainable water resource management priorities, all new improvements completed with this project will utilize premium efficient motors where feasible. New PLC controls and SCADA alarming will help the new facilities to operate efficiently. This will be important for efficient operation and management of the pump station and pipeline projects.



6.5 ENGINEER’S OPINION OF PROBABLE COSTS

The total capital cost for this project is estimated to be \$13,134,000 and is detailed in **Table 24**.

Table 24 Total Project Cost Estimate

ITEM	Subtotal	Total
Property Purchase / Lease Agreements		--
Easement Acquisition / Right of Way / Water Rights		\$15,000
Bond Counsel		--
Legal Counsel		--
Interest/Refinancing Expense		--
Other		
Other (connection fee)		\$4,670,000
Environmental Services		
- CEQA Environmental Report	\$40,000	
- NEPA Environmental Report	\$10,000	
- Environmental Mitigation Contract Services	\$10,000	
Total - Environmental Services:		\$60,000
Engineering Services		
<i>Basic Services:</i>		
- Preliminary Engineering Report (PER)	\$112,000	
- Preliminary and Final Design Phase Services	\$401,000	
- Bidding/Contract Award Phase Services	\$40,000	
- Construction and Post-Construction Phase Services (w/o inspection)	\$300,000	
- Resident Project Representative Services (resident inspector)	\$504,000	
<i>Additional Services:</i>		
- Permitting	\$40,000	
- Regulatory Compliance Reports	\$5,000	
- Environmental Mitigation Services (Construction Phase)	\$10,000	
- Easement Acquisition/ROW's Services (Construction Phase)	--	
- Surveying Services (Construction Phase)	\$10,000	
- Operation & Maintenance Manual(s)	\$25,000	
- Geotechnical Services	\$20,000	
- Hydrogeologist Services	--	
- Materials Testing Services (Construction Phase)	\$25,000	
- Other Services (describe)	---	
Total – Engineering Services:		\$ 1,492,000
Equipment/Materials (Direct purchase using approved methods, separate from construction bid/cost)		--
Construction Cost Estimate (escalated to mid-point of construction)		\$ 6,270,000
Contingency (10% of construction cost estimate)		\$ 627,000
TOTAL PROJECT COST ESTIMATE:		\$ 13,134,000



6.6 ANNUAL OPERATING BUDGET

6.6.1 Income

The City currently charges residential and commercial customers the rates summarized below, as detailed in **Section 2.4**:

- the base rate of \$83.61/month (residential),
- \$84.03 (commercial), and
- Cost per 1,000 gallons: \$9.10/month (standard strength), \$13.63/month (moderate strength), and \$18.18/month (high strength).

Based on the 2019 Auditor’s Report and Financial Statement, the City’s annual operating revenue collected from water and sewer fees was \$1,312,018 and \$1,182,920, respectively.

6.6.2 Annual O&M Costs

The existing SBR and filters will be replaced with an equalization basin, pump station, and regional pipeline (for treatment at the Hollister WWTP). Operation and maintenance costs resulting from the proposed Project are anticipated to decrease and the amount of contract labor needed for operations will also be less, but regional service fees will be added. **Table 25**, below, includes an estimate of the approximate annual operations and maintenance costs of the new facility.

Table 25 Projected Operations and Maintenance Costs

Annual O&M Cost Estimate ¹	Sewer
Operating Expense	
Contractual Services and Utilities ²	150,000
Regional Service Fees (Hollister WWTP)	772,592
Personnel	55,000
Supplies, Materials, and Repairs ²	222,990
Depreciation	308,686
Total Operating Expense	1,509,268

1. Based on 2019 O&M costs minus approximately half the cost of wastewater utilities, supplies and personnel, plus additional regional service fees (Hollister WWTP service fees).
2. Utilities and supplies may be decreased even further than shown in table, since the five year average is lower than the 2019 basis.



6.6.3 Debt Repayments

Based on the June 2019 Auditor’s Report and Financial Statement (as detailed in **Appendix B**), the City issued an Enterprise Revenue Bond for the principal amount of \$11,640,000. The bond paid for the 2008 Water and Sewer COP and Pavex Note. The cash basis debt service paid during the fiscal year ending on June 30, 2020, totals \$687,064. The bonds bear interest ranging from 3 to 5-percent and are payable semi-annually, ending on October 2043.

Based on a total Project Cost of \$11,134,000 (as shown in Table 24) and an estimated 45% grant from USDA, the City will need to borrow \$7,224,000 to pay for the project. Based on an assumed interest rate of 1.375% (current USDA poverty interest rate) and a 40-year term loan, the annual debt service will be \$236,000.

The City has limited revenues available to support another loan obligation while keeping user fees manageable for the small city of San Juan Bautista. The City is hoping they will be eligible for additional grant assistance from other sources.

6.6.4 Reserves

Based on the June 2019 Auditor’s Report and Financial Statement (as detailed in **Appendix B**), the current “restricted” reserves for the sewer funds is \$369,326. The City’s net asset positions are summarized in **Table 26**.

Table 26 Statement of Net Asset Positions

Item	Sewer
Current Assets	
Cash and Investments	\$1,189,873
Restricted Cash and Investments	\$369,326
Accounts Receivable, Net	\$98,320
Total Current Assets	\$1,657,519
Non-Current Assets	
Property, Plant, and Equipment	\$6,052,741
Total Assets	
Total Assets	\$7,710,260



7.0 CONCLUSION AND RECOMMENDATIONS

The Apparent Best Project for the City of San Juan Bautista includes the following components:

- Implement an industrial pre-treatment program for salinity control
- Install a new raw sewage pump station and 8-inch wastewater pipeline to the Hollister WWTPP and decommission the existing sequencing batch reactor (SBR) pond and convert to an equalization basin.
- Construct a 12-inch potable water line from the West Hills WTP to the City of San Juan Bautista
- Execute self-regenerating water softener buy-back program



APPENDIX A

2020 Water and Wastewater Masterplan

APPENDIX B

Current City Budget and Financial Audits

SAN JUAN BAUTISTA, WASTEWATER TREATMENT IMPROVEMENTS PROJECT

Appendix C Violation Notices and Regional Board Comments

APPENDIX C

Violation Notices and Regional Board Comments

APPENDIX D

Pellet Plant Report



APPENDIX B

Rancho Vista Sewer Lift Station Compliance Review



**City of San Juan Bautista –
Rancho Vista Sewer Lift Station
Compliance Review**

September 11, 2020

Prepared for:

City of San Juan Bautista

Submitted to:

Akel Engineering Group, Inc.

Prepared by:

Stantec Consulting Services Inc.



Table of Contents

1.0	INTRODUCTION	1
1.1	PURPOSE AND METHODOLOGY	1
2.0	RANCHO VISTA SEWER LIFT STATION	1
2.1	GENERAL SITE EVALUATION AND ACCESS	1
2.2	WET WELL, PUMPS, VALVES AND OTHER APPURTENANCES	2
2.3	SYSTEM HYDRAULICS.....	7
2.4	ELECTRICAL	7
3.0	FINDINGS	9
4.0	RECOMMENDATIONS	10

LIST OF TABLES

Table 1 – Major Observations and Findings	9
Table 2 – Recommendations	10

LIST OF FIGURES

Figure 1 – RVSLS Site	2
Figure 2 – RVSLS Wet Well Access Hatch	4
Figure 3 – Inside RVSLS Wet Well.....	5
Figure 4 – RVSLS Valve Vault With Standing Water	6
Figure 5 – Possible Signs Of Infiltration Through The Concrete Joints.....	7
Figure 6 – RVSLS Control Panel And Alarm System.....	8
Figure 7 – Entrance And Fencing For The RVSLS.....	12

LIST OF APPENDICES

APPENDIX A	HOMA PUMP TECHNICAL INFORMATION	A.1
APPENDIX B	ADDITIONAL PICTURES	B.1

LIST OF APPENDICES FIGURES

Figure B.1 – Inside Door Of Control Panel	B.2
Figure B.2 – Control Panel Builder Information	B.3
Figure B.3 – Control Panel Information	B.3



Figure B.4 – Control Panel Enclosure Information..... B.4
Figure B.5 – HOMA Pump Information..... B.4
Figure B.6 – Control Panel Screen..... B.5



Introduction

1.0 INTRODUCTION

The Rancho Vista Sewer Lift Station (RVSL) was constructed by Meritage Homes Corporation in 2017 as part of the new Rancho Vista neighborhood development within the City of San Juan Bautista (City) sewer collection service area.

1.1 PURPOSE AND METHODOLOGY

The purpose of this report is to assess the station's compliance with applicable industry standards. Stantec Consulting Services Inc. (Stantec) reviewed available information for the RVSL, which included equipment submittals from the pump manufacturer, a mechanical detail drawing, and a visual inspection of the installed infrastructure. This assessment was performed without review of City specifications, which were not available for the RVSL.

To perform the compliance review, Stantec and Akel Engineering Group, Inc. (Akel) performed a site visit of the RVSL with City staff on February 14, 2020. In addition to a visual inspection, Stantec and Akel discussed with City staff their experiences and concerns about operation and maintenance of the RVSL.

2.0 RANCHO VISTA SEWER LIFT STATION

2.1 GENERAL SITE EVALUATION AND ACCESS

The RVSL is located on the intersection of Third Street and Lavagnino Drive in the Rancho Vista neighborhood in San Juan Bautista, California. The lift station includes a valve vault, wet well with duplex submersible pumps, odor control valve, and a control panel. The lift station site is covered in bark, contains young landscaping, and is in an area with light traffic conditions. In the event that a pump needs to be lifted out of the wet well or the wet well needs to be washed down during routine maintenance, a firm and stable work area surrounding the wet well is not available. Existing landscaping immediately surrounding the hatches pose a risk for contamination and proper wash down of the area may not be possible. There is no paved access to the site, the fencing surrounding the site is unsecure, and no lighting was identified. The unsecure fencing is approximately 3-feet tall, which poses a safety hazard for City employees and residents and allows for possible vandalism at the lift station site. A potable water connection was not identified at the site for wash down and routine maintenance. The RVSL site is shown in Figure 1.



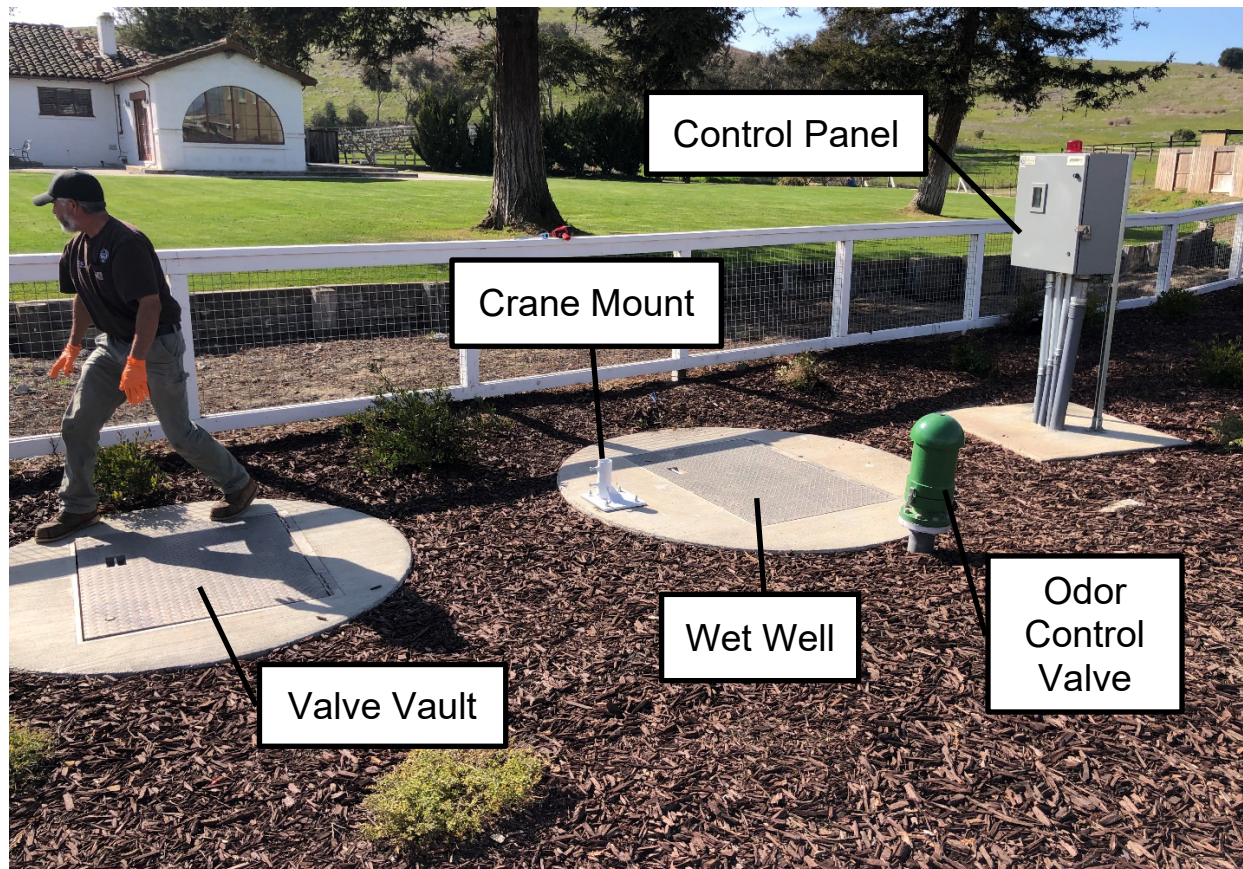

Figure 1 – RVSL Site

2.2 WET WELL, PUMPS, VALVES AND OTHER APPURTENANCES

The wet well has an inner diameter of 6 ft and is 21 ft deep with an operating volume of 317 gallons and a total capacity of 4,441 gallons. The wet well is un-lined concrete, which will corrode from prolonged exposure to sulfuric acids found in municipal wastewater. Additionally, the 90-degree elbows on each discharge pipe in the wet well showed signs of rust and corrosion. There were no grouted side sloped chamfers around the bottom of the pump station, which will likely lead to settled solids getting stuck around the edge of the wet well. Hydraulic Institute (HI) 9.8 recommends sloped grout fill. The remote wet well system, with no feedback to a SCADA system, does not include an underground overflow tank, but one could be installed if the City desires to reduce risk of overflow.

The wet well contains two submersible pumps each with a single vane impeller (HOMA Pump Technology Inc. model TP53M35/4/3). The pumps were each designed for an operating point of 100 gallons per minute (gpm) and a total dynamic head of 31.2 ft. At this operating point, the pumps are operating at an efficiency of 51.6%. These are low efficiency pumps, which result in faster wear and tear on the



CITY OF SAN JUAN BAUTISTA – RANCHO VISTA SEWER LIFT STATION COMPLIANCE REVIEW

Rancho Vista Sewer Lift Station

mechanical components of the pumps than high efficiency pumps. The maximum flow and head that the pump is capable of achieving is 295 gpm and 49.3 ft, respectively. Each pump is rated for 2.68 horsepower, 3 phase (PH), 230 volts (V), 8.8 amps (A), and 1750 rotations per minute (rpm). More information on the HOMA pumps are included in Appendix A. At the time of the site visit (February 14, 2020), City's field notes indicated the average daily run times for Pumps No. 1 and No. 2 are approximately half an hour per day per pump. The pump run times depict that the pumps are adequately sized for the incoming flows and operate normally. As of February 14, 2020, the total Pump No. 1 run time was 678.5 hours and Pump No. 2 total run time was 321.0 hours. The difference in pump run times may be attributed to Pump No. 2 being out of service from November 2019 to January 2020 because the pump got clogged and the moisture sensor wire was damaged. The pumps are operated on alternating cycles, which offers redundancy for this size of a lift station. The wet well and pumps are shown in Figure 2 and Figure 3.

A representative with HOMA Pump Technology Inc. indicated that it is good practice to pull the pumps out of the wet well once per year for inspection and to check the amperage weekly to determine if the pumps are operating as intended. A crane mount was observed next to the wet well. It should be confirmed that the City has a portable crane system or mechanism to remove the pumps from the wet well.

During the site visit, blue latex gloves were observed in the wet well that came from somewhere in the Rancho Vista development. The blue latex gloves, as shown in Figure 3, could cause blockages or cause the impeller to spin incorrectly. Possible solutions include direct communications with the sewer customers flushing gloves, installing a screening system on the inlet to the wet well, or installing a grinder pump. If the screening system is installed, City maintenance staff would have to routinely remove the gloves and other debris that collect on the screen.

The odor control valve is east of the wet well, above the inlet pipe. A sewage air release valve (SARV) was not observed on the lift station site. It is typical for a SARV to either be installed at the high point on the force main or be connected with a pressure gauge to both discharge pipes between the wet well and valve vault.



CITY OF SAN JUAN BAUTISTA – RANCHO VISTA SEWER LIFT STATION COMPLIANCE REVIEW

Rancho Vista Sewer Lift Station



Figure 2 – RVSLs Wet Well Access Hatch



Rancho Vista Sewer Lift Station

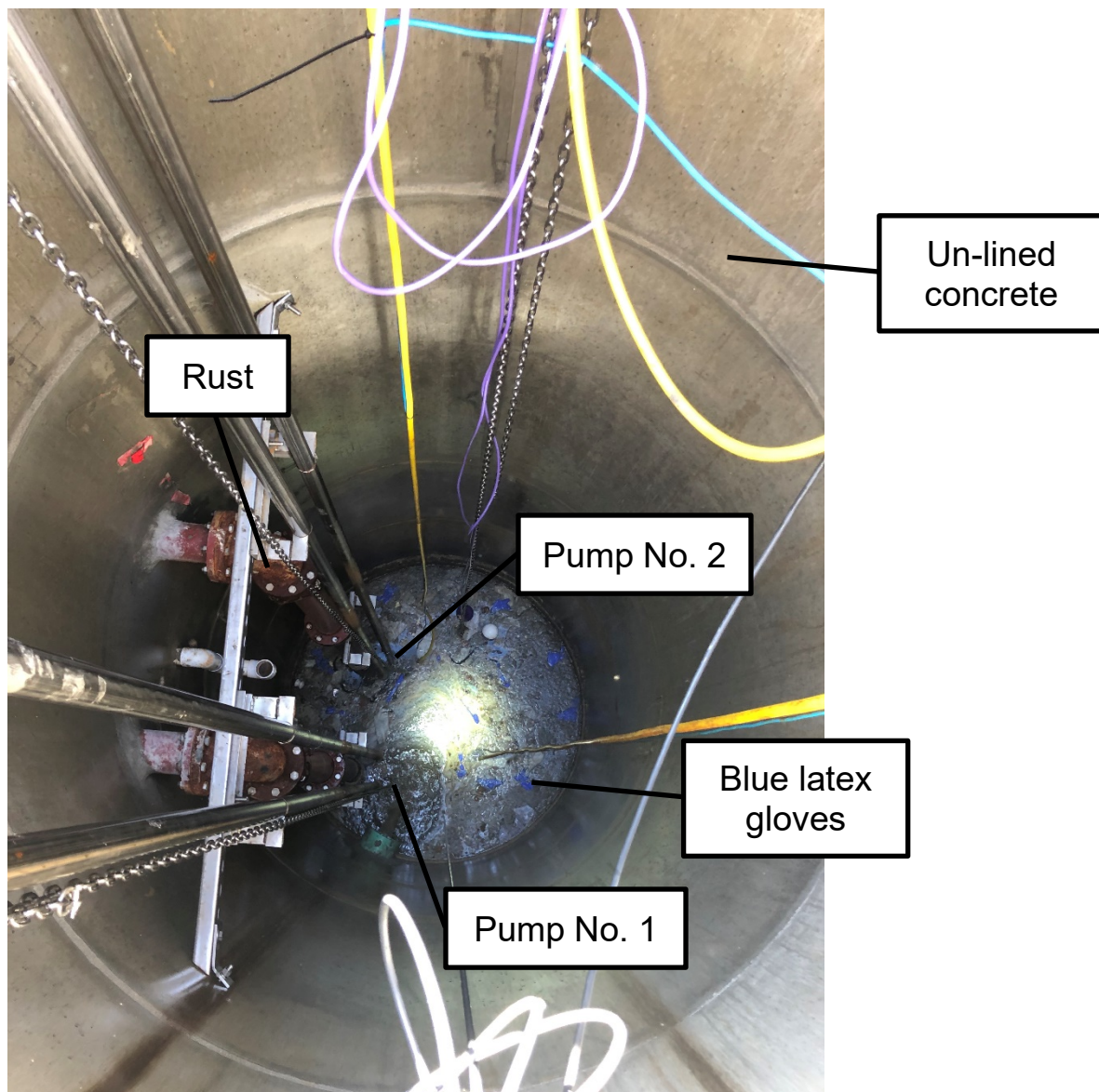

Figure 3 – Inside RVSLS Wet Well

The valve vault, which contains check valves, plug valves, and appurtenances, has a 5 ft inner diameter and is 10.5 ft deep. As shown in Figure 4, there was standing water in the valve vault at the time of the site visit. Although the section drawing of the lift station shows the drain pipe outlet (into the wet well) at a lower elevation than the inlet (in the valve vault), the drain pipe or p-trap may have been installed incorrectly. Another explanation for the standing water could be that the drain pipe is clogged. The standing water observed at the bottom of the valve vault could be intruding through the concrete joints.



CITY OF SAN JUAN BAUTISTA – RANCHO VISTA SEWER LIFT STATION COMPLIANCE REVIEW

Rancho Vista Sewer Lift Station

Figure 4 and Figure 5 shows possible signs of infiltration at the concrete joints and water staining on the edges, potentially indicating a lack of seal.

The RVSLS does not have the proper safety equipment. Neither the valve vault nor the wet well have fall protection. Additionally, City staff noted that to enter the valve vault for routine maintenance, they have used a ladder. Proper confined space entry equipment, such as a portable tripod system, should be utilized to ensure the safety of City maintenance staff. Further, the vault can be fitted with an OSHA compliant access ladder with pull-up access pole and safety rail harness.



Figure 4 – RVSLS Valve Vault With Standing Water



Rancho Vista Sewer Lift Station



Figure 5 – Possible Signs Of Infiltration Through The Concrete Joints

2.3 SYSTEM HYDRAULICS

As part of the master plan modeling work, the existing and buildout peak flows were determined for dry and wet weather. The RVSLS has sufficient firm capacity (100 gpm) to handle the current peak wet weather flow of 77.1 gpm and the buildout peak wet weather flow of 90.1 gpm.

A flow meter was not identified at the lift station. For improved monitoring, a flow meter could be installed on the discharge force main, downstream of the valve vault, if the City desires.

2.4 ELECTRICAL

The control panel was constructed by California Motor Controls. The primary power supply is 240 V, 3 PH, 60 Hz, and 18.25 A. There is currently no backup generator. The control panel enclosure is NEMA 3R rated. No seal fittings on the conduits were observed during the site visit. Per the National Fire Protection Association 70 National Electrical Code Article 501.15(b), a raceway seal fitting must be installed in each raceway that transitions from a classified location to an unclassified location.

Currently, there is no alarm telemetry. In the event that the alarm goes off, the City has an official telephone number for the nearby City residents to call. There is a sign on the fence at the RVSLS site that provides a phone number to call during business hours and after hours. The alarm system leaves the City vulnerable in the event of an emergency. The current alarm system is shown in Figure 6.



CITY OF SAN JUAN BAUTISTA – RANCHO VISTA SEWER LIFT STATION COMPLIANCE REVIEW

Rancho Vista Sewer Lift Station



Figure 6 – RVSLs Control Panel And Alarm System



Findings

3.0 FINDINGS

Table 1 shows the major observations and findings regarding the RVSLs.

Table 1 – Major Observations and Findings

Discipline	Observations/Findings
General Site and Access	<ul style="list-style-type: none"> • Good condition concrete wet well and access hatch • Fencing is unsecure • Poor site access • Site is covered in bark and landscaping • No lighting is available
Wet Well, Pumps, Valves, and other Appurtenances	<ul style="list-style-type: none"> • Wet well is un-lined concrete • Noted rust/corrosion on 90-degree elbow on both discharge piping in wet well • Blue latex gloves in the wet well • Low efficiency pumps • No bypass capability or quick connection • No personnel access ability into the valve vault • Standing water in the valve vault • No fall protection on the valve vault or the wet well • Possible signs of infiltration at the concrete joints of the valve vault • No SARV
System Hydraulics	<ul style="list-style-type: none"> • Sufficient firm capacity to handle current and buildout peak wet weather flow • No flow meter
Electrical	<ul style="list-style-type: none"> • No alarm telemetry • No backup generator • No seal fittings on conduits • NEMA 3R rated control panel box



Recommendations

4.0 RECOMMENDATIONS

Table 2 shows a list of recommendations to bring the RVSLS up to industry standards.

Table 2 – Recommendations

Discipline	Recommendations
General Site and Access	<ul style="list-style-type: none"> • Replace the fencing around the equipment with more secure fencing. Per industry standard, the fence should have a minimum height of 6 ft. Possible fencing options, which vary by the level of security and appearance, include a chain link fence, wrought iron fence, or a concrete masonry unit (CMU) wall. Screening can be added to the chain link fence or the wrought iron fence to further reduce visibility into the lift station site. The City and the Homeowners Association should agree on the type of fencing to ensure it is secure, while also blending with the neighborhood to the extent feasible. • Provide a paved or concrete driveway from the street to the wet well and valve vault (Figure 7). • Pave or construct a concrete pad around the valve vault, wet well, and control panel site, extending 5 ft from the equipment (where available) on all sides to allow for easier wash down and routine maintenance. The pad should slope towards the wet well for proper drainage. • Confirm there is a water connection available for wash down and routine maintenance. • Provide lighting for night work and safety.
Wet Well, Pumps, Valves, and other Appurtenances	<ul style="list-style-type: none"> • Protect the wet well and discharge pipes with corrosion resistant high solids epoxy coating system. • Install grouted side sloped chamfers around the bottom of the wet well, as recommended by HI 9.8. • Prevent blockages that could be caused by the blue latex gloves through direct communications with the sewer customers flushing gloves, a screening system on the wet well inlet, or a grinder pump. • If the pumps experience mechanical issues, due to normal wear and tear of the mechanical components, replace the low efficiency pumps with high efficiency pumps, such as Flygt or ABS pumps. • Install a quick connection/disconnect fitting to provide an ability for bypass pumping in emergency situations.



CITY OF SAN JUAN BAUTISTA – RANCHO VISTA SEWER LIFT STATION COMPLIANCE REVIEW

Recommendations

	<ul style="list-style-type: none"> • Confirm the City has a portable crane system to remove the pumps out of the wet well. • Install an OSHA compliant ladder in the valve vault. Use proper confined space entry equipment, such as a portable tripod system, to enter the valve vault. • Check the invert elevations of the drain pipe between the valve vault and wet well to ensure it's sloping towards the wet well. • Check whether the drain pipe from the valve vault to the wet well is clogged and if so, unclog it. • Install fall protection under the access hatch on the valve vault and the wet well. • Investigate the possible signs of infiltration at the concrete joints by vacuum testing the vault. • An SARV and pressure gauge should be connected to both discharge pipes if an SARV is not already connected at the high-point of the force main. • Consider possibly installing an underground overflow tank since the wet well is remote
System Hydraulics	<ul style="list-style-type: none"> • Consider possibly installing a flow meter on the force main discharge pipe.
Electrical	<ul style="list-style-type: none"> • Install alarm telemetry so the City is alerted instantly. A cost-effective system is an auto-dialer, such as RACO AlarmAgent or similar, which could automatically call or text City personnel when an alarm occurs. A more complex system could be investigated if the City desires additional functionality, such as the ability to remotely start/stop pumps. • Install a backup generator to reduce vulnerability. • Install seal fittings on the conduits running from the wet well to the control panel enclosure. • Install NEMA 4X stainless steel control panel box to protect from corrosion and outdoor environmental challenges (rain, wind, dust, etc.).



Recommendations



Figure 7 – Entrance And Fencing For The RVSLs



APPENDIX A

HOMA PUMP TECHNICAL INFORMATION



Submersible Wastewater Pumps with single Vane impeller 3" Discharge – 2" Solids

TP 53 M

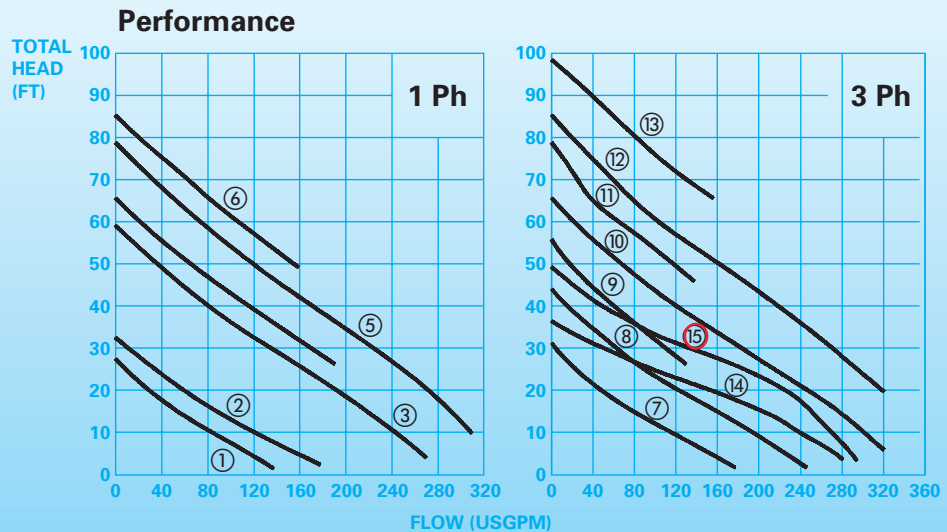

Application

The HOMA TP 53 Series of submersible pumps are ideal for wastewater and sewage service in residential, commercial and industrial applications. The TP 53 is also excellent for drainage applications where large solids are present.

Typical Fluids Handled Are:

- Clear and Drainage Water
- Effluent and Sewage with Soft Solids
- Liquids to 140 F can be handled intermittantly
- PH Range 5 – 9 with Specific Gravity to 1.1

TP 50 Series pumps are typically used in:

- Residential and Commercial Sewage
- Industrial Wastewater
- Effluent Distribution Systems
- Agricultural Wastewater
- Pond or Lake Water
- Processing Plants
- Optional Factory Mutual (FM) label for Class I, Div 1 EX construction.

Features

Integral Lift Handle is arched to permit self centering of lifting device

Cast Iron Construction with Epoxy Coating for maximum corrosion resistance

Extra Long Replaceable power cable of 33' length is retained and sealed with a strain relief gland

Standard Lower Seal material is Silicon Carbide

Shown: Integral Mounting Stand for transportable applications. Optional: HOMA AutoCoupling System for permanent installations

Upper and Lower High Capacity Ball Bearings assure long life and reliability

Motor windings provided with Class H insulation and fully protected by embedded auto reset thermal switches

Oil Filled Seal Chamber positively lubricates seals and permits a seal leakage probe to be installed

Single Vane impeller for large solids handling

Replaceable volute wear ring in single vane pump permits hydraulic efficiency to be restored for long service life

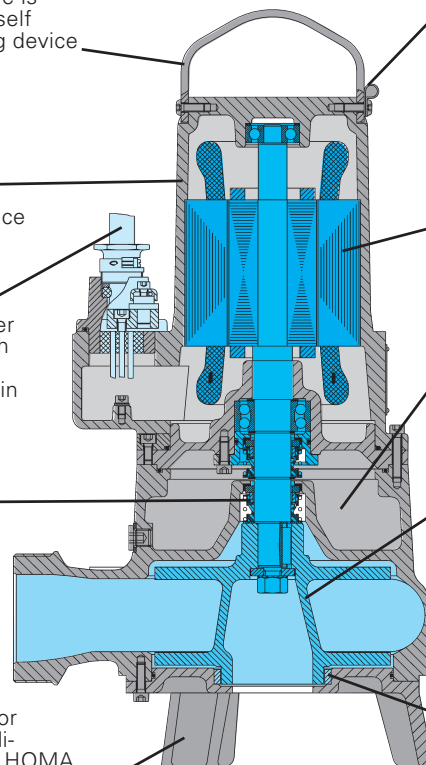

Motor Construction

Motor Type:

enclosed submersible

NEMA Insulation Code: class H

Service Factor: 1.15

NEMA Design Type: B

Standard Cable Length: 33 ft

Available Motor Voltages:

1 Phase: 115 V, 200 V, 230 V

3 Phase: 200 V, 220 V, 230 V, 380 V
460 V, 575 V

Optional Explosion Proof construction:

Factory Mutual approved for Class I,
Div. 1, Group C & D.

Installations

Wet pit with autocoupling

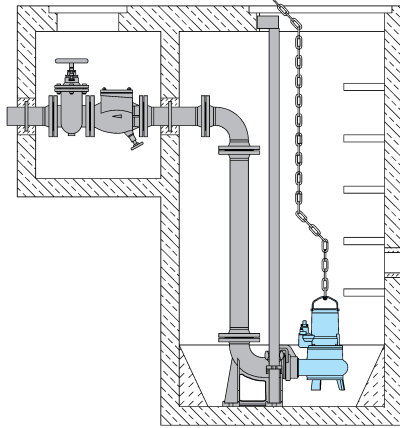

Basestand

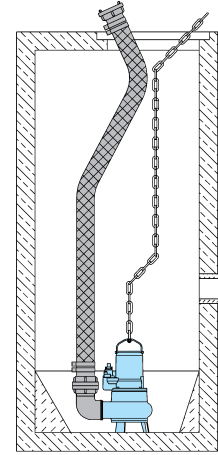

Materials

Motor housing, Volute and Impeller

Cast Iron ASTM A 48, Class 40B

Mechanical seals – Impeller side

Silicon Carbide vs Silicon Carbide

Shaft seal - Motor side

Other Models: mechanical seal

(Silicon Carbide vs Silicon Carbide)

TP53M16... -M24...:Lip Seal

O-Rings: Nitrile Rubber

Upper Bearings:

Deep groove Ball Bearing

Lower Bearings:

Other models:

Double row angular Ball Bearing

TP53M16... -M24 (not FM models):

Deep groove Ball Bearing

Power cable sheathing:

Nitrile Rubber

Shaft: AISI 430 F

Fasteners: AISI 304 SS

Dimensions (inches) (Tolerance +/- 1/4")

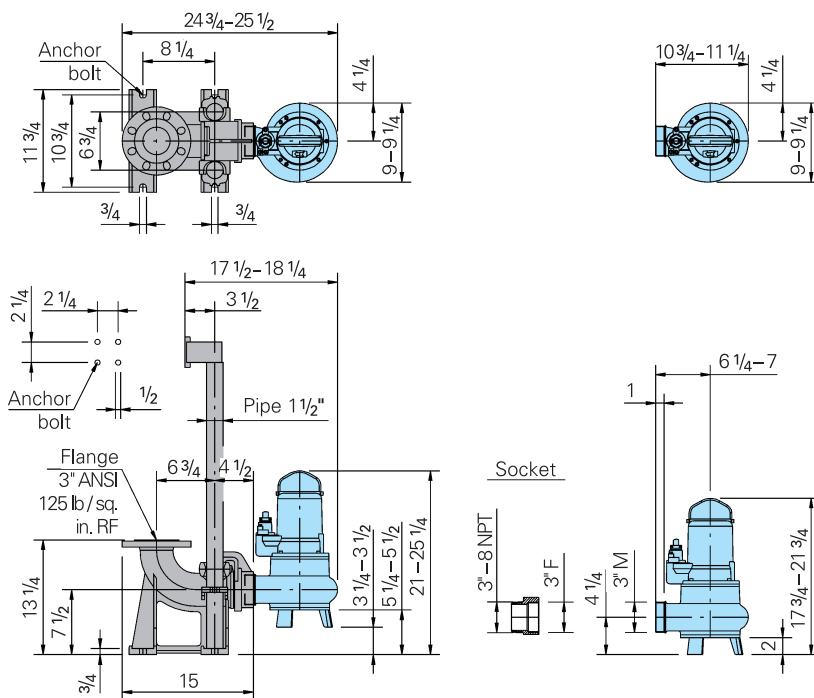

Technical Data

Curve No.	Pump Type	Rated B.H.P.	Phase	Voltage (V)	Full Load Amps	Speed (rpm)	Weight (LBS)	NEMA code
1	TP53M16/2/1	1.2	1	230	5.4	3450	57	F
2	TP53M24/2/1	1.7	1	230	7.8	3450	55	F
3	TP53M38L/2/1	2.6	1	230	12.0	3450	88	F
4	TP53M38H/2/1	2.6	1	230	12.0	3450	88	F
5	TP53M54L/2/1	4.3	1	230	18.5	3450	99	F
6	TP53M54H/2/1	4.3	1	230	18.5	3450	99	F
7	TP53M16/2/3	1.2	3	230/380/460	3.8/2.3/1.9	3450	57	G
8	TP53M24L/2/3	1.9	3	230/380/460	5.4/3.3/2.7	3450	55	G
9	TP53M24H/2/3	1.9	3	230/380/460	5.4/3.3/2.7	3450	55	G
10	TP53M38L/2/3	3.1	3	230/380/460	8.0/4.8/4.0	3450	88	F
11	TP53M38H/2/3	3.1	3	230/380/460	8.0/4.8/4.0	3450	88	F
12	TP53M54L/2/3	4.7	3	230/380/460	12.0/7.2/6.0	3450	99	F
13	TP53M54H/2/3	4.7	3	230/380/460	12.0/7.2/6.0	3450	99	F
14	TP53M23/4/3	1.6	3	230/380/460	5.2/3.2/2.6	1750	88	G
15	TP53M35/4/3	2.5	3	230/380/460	8.8/5.3/4.4	1750	99	G

Technical Data

TP53M35/4/3FM



Operating data				
Flow	100	US g.p.m.	Head	31.2 ft
Shaft power P2	1.7	hp	Static head	20 ft
Pump efficiency	51.6	%	Required pump NPSH	ft
Pumpe type	Single pump		No. of pumps	1
Fluid	Wastewater		Temperature	68 °F
Density	62.31	lb/ft ³	Kin. viscosity	1.077E-5 ft ² /s

Pump				
Pump Code	TP53M35/4/3FM		Speed	1750 rpm
Suction port			Head	Max. 49.3 ft
Discharge port	3" - 8 NPT			Min. 3.1 ft
Impeller type	Single vane impeller		Flow	Max. 295.0 US g.p.m.
Solid size	2	inch		Pump efficiency max.
Impeller Ø	6.34	inch	Required rated power max. P2	2.5 hp

Motor					
Motor design	Submersible motor		Insulation class	H	
Motor name	AM136.4.6/4/3		Degree of protection	IP 68	
Frequency	60	Hz	Temperature class	T4	
Rated power P1	3.0	hp	NEMA code	G	
Rated power P2	2.5	hp	Explosion protection	Class I, Div. 1, Grp C&D	
Rated speed	1750	rpm	Efficiency at % rated power	100% 85.0 %	
Rated voltage	230	/ 460 V 3~		75%	%
Rated current	8.8	/ 4,4 A		50%	%
Starting current, direct starting	35.2	A	cos phi at % rated power	100% 0.84	
Starting current, star-delta	11	A		75%	
Starting mode	Directly			50%	
Power cable	7X1,5		Control cable		
Type of power cable	NSSHÖU-J		Type of control cable		
Cable length	32.809 ft		Service factor	1.15	
Shaft seal	Mechanical seal on medium side		SiC / SiC		
	Mechanical seal on motor side		SiC / SiC		
Bearing	Lower Bearing		Double row angular ball bearing		
	Upper Bearing		Deep Groove Ball Bearing		
Remarks					

Materials / Weight			
Motor housing	Cast Iron ASTM A48;Cl.40B	Bolts	AISI 304 Stainless Steel
Pump housing	Cast Iron ASTM A48;Cl.40B	O-Rings	Nitrile Rubber
Impeller	Cast Iron ASTM A48;Cl.40B		
Wear ring	Bronze ASTM B144		
Motor shaft	AISI 430 F Stainless Steel		
Weight aggregat	99.206 lb		

Project	Project no.:	Created by:	Page: 4	Date: 2017-05-16
---------	--------------	-------------	---------	------------------

Performance Curve

TP53M35/4/3FM



Impeller					
Impeller type: Single vane impeller	Solid size 2 inch	Ø:	Max. Ø: 6 ⁵ / ₁₆ "	Min. Ø: 3 ⁵ / ₁₆ "	Sel. Ø: 6 ⁵ / ₁₆ "
Operating data					
Speed: 1750 rpm	Frequency: 60 Hz	Duty point Q = 100 US g.p.m. H = 31.2 ft	Shaft power P2: 1.72 hp	Discharge port: 3" - 8 NPT	

Power data referred to:
Water [100%] ; 68°F; 62.322lb/ft³; 1.0818E-5ft²/s

Testnorm: HI Standard Sect. 14.6.3.4.1

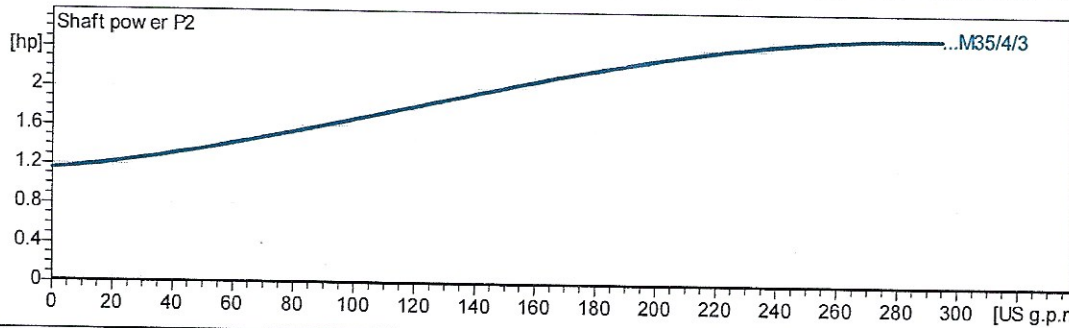
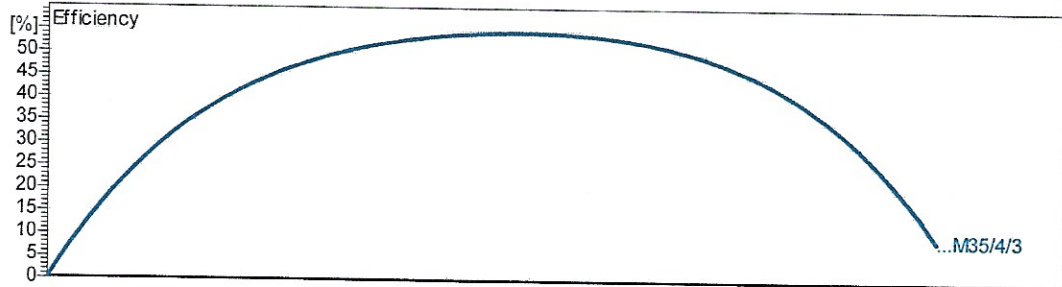
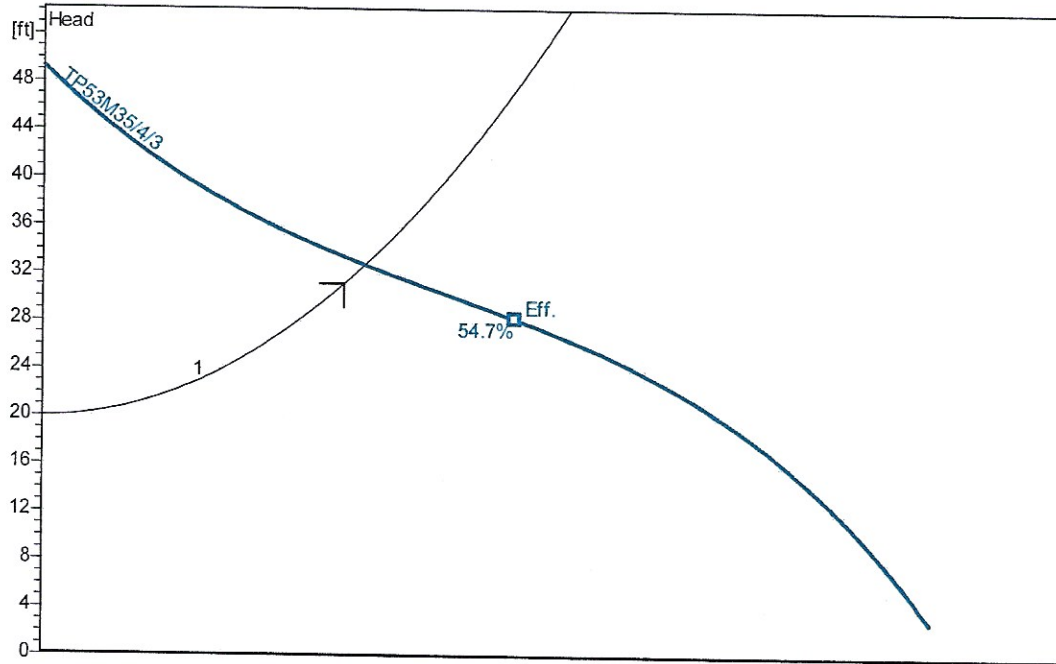

201 - 13.09.2016 (Build 100)

Project	Project no.:	Created by:	Page: 2	Date: 2017-05-16
---------	--------------	-------------	------------	---------------------

Technical Information

TP53M35/4/3FM



Operating data	
Flow	100 US g.p.m.
Head	31.2 ft
Shaft power P2	1.72 hp
Pump efficiency	51.6 %
Required pump NPSH	
Pumpe type	Single pump
No. of pumps	1
Fluid	Wastewater
Pump	
Pump Code	TP53M35/4/3FM
Impeller	Single vane impeller
Impeller size	6 ⁵ / ₁₆ "
Solid size	2 inch
Discharge port	3" - 8 NPT
Suction port	
Motor	
Rated voltage	230/ 460 V
Frequency	60 Hz
Rated power P2	2.5 hp
Rated speed	1750 rpm
Number of poles	4
Efficiency	85 %
Rated current	8.8 / 4.4A
Degree of protection	IP 68
Materials	
Motor housing	Cast Iron ASTM A48, Cl. 40B
Impeller	Cast Iron ASTM A48, Cl. 40B
Pump housing	Cast Iron ASTM A48, Cl. 40B
Wear ring	Bronze ASTM B144
Motor shaft	AISI 430 F Stainless Steel
Bolts	AISI 304 Stainless Steel
O-Rings	Nitrile Rubber
Mechanical seal on medium side	SiC / SiC
Mechanical seal on motor side	SiC / SiC
Lower Bearing	Double row angular ball bearing
Upper Bearing	Deep Groove Ball Bearing

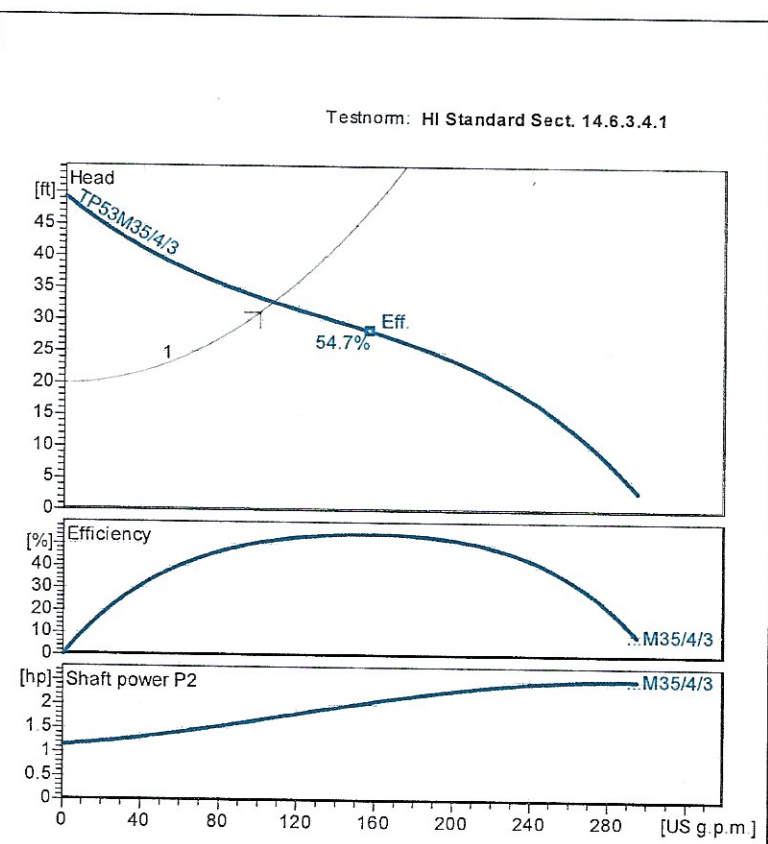

Wet well installation with coupling kit 3" ANSI
 Dimensions in mm [inch], letters see table

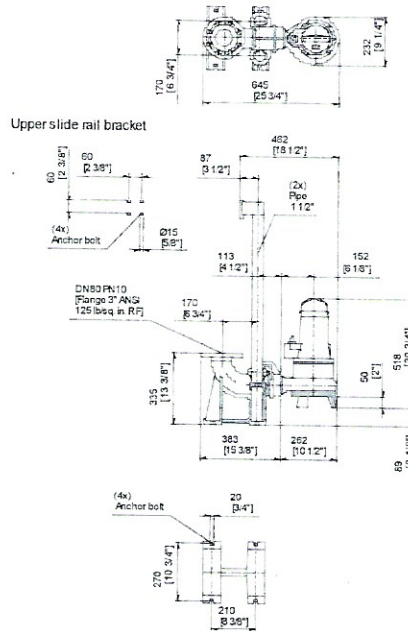
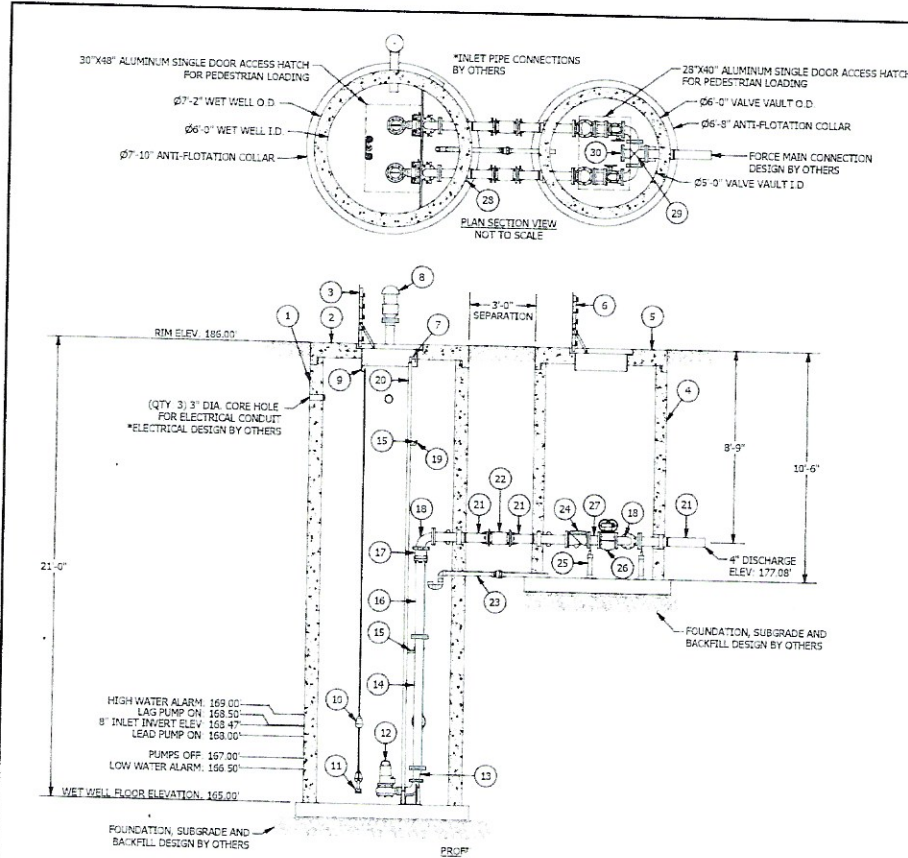

Table Dimensions (inch)

201 - 13.09.2016 (Build 100)

Project	Project no.:	Created by:	Page: 1	Date: 2017-05-16
---------	--------------	-------------	---------	------------------

Rancho Vista



PARTS LIST		
ITEM	QTY	DESCRIPTION
1	1	72" DIA. JENSEN PRECAST CONCRETE MANHOLE, 21'-0" DEEP (RIM TO SUMP)
2	1	72" DIA. JENSEN PRECAST CONCRETE MANHOLE FLAT TOP
3	1	30x48 ALUMINUM SINGLE DOOR ACCESS HATCH
4	1	60" DIA. JENSEN PRECAST CONCRETE MANHOLE, 10'-6" DEEP (RIM TO SUMP)
5	1	60" DIA. JENSEN PRECAST CONCRETE MANHOLE FLAT TOP
6	1	28x40 ALUMINUM SINGLE DOOR ACCESS HATCH
7	2	304SS UPPER GUIDE RAIL BRACKET
8	1	4" DIA. WAGER 1800 DOOR CONTROL SEWER VALVE W/ PVC PIPING ASSEMBLY
9	1	304 SS 3048 FLAT BRACKET
10	2	OPTICAL FLOAT SWITCH BY OPTI-FLOAT
11	1	SS SUBMERSIBLE PRESSURE TRANSDUCER, 15 PSI, 100' CORD LENGTH
12	2	HOMA SUBMERSIBLE NON-CLOG PUMP WITH 3" FLANGED DISCHARGE AUTOCOUPLING, 2" SOLIDS HANDLING, THERMAL AND SEAL FAIL SENSORS, AND 50' CABLE
13	2	4" X 3" FLG DI ECCENTRIC REDUCER
14	2	4" DIA. DI FLG X FLG 6'-0" SPOOL
15	4	304 SS INTERMEDIATE GUIDE RAIL BRACKET
16	2	4" DIA. DI FLG X PE 3'-8" SPOOL
17	2	4" DIA. RFLG W/ SS HRDWR
18	4	4" DIA. DI FLG 90 ELBOW
19	6	L.F. UNISTRUT NUT RAIL
20	100	L.F. 1 1/2" DIA. 304SS GUIDE RAIL PIPE
21	5	4" DIA. DI FLG X PE 3'-0" SPOOL
22	2	4" DIA. DI FLG X PE 3'-0" SPOOL
23	1	2" SCH40 PVC DRAIN WITH CHECK VALVE AND TRAP
24	2	4" DIA. FLANGED SWING CHECK VALVE BY VAL-MATIC
25	3	ADJUSTABLE PIPE STAND, FLG STYLE, FOR 4" DIP
26	2	4" DIA. FLANGED PLUG VALVE W/ HANDWHEEL BY VAL-MATIC
27	2	4" DIA. DI FLG X FLG 0'-6" SPOOL
28	5	FLEXIBLE BOOT TYPE PIPE CONNECTOR FOR 4" DI
29	1	4" DIA. DI FLANGED CROSS
30	1	4" DIA. DI BLIND FLANGE

SYSTEM CHARACTERISTICS	
DESCRIPTION	VALUE
DUTY POINT	100 gpm @ 31.2' TDH
MANUFACTURER	HOMA
MODEL NUMBER	TP53M35/42FM
PUMP TYPE	SUBMERSIBLE NON-CLOG PUMP
MOTOR SIZE	2.9 hp, 8.8 A
MAX PUMP RUN SPEED	1750
AVAILABLE POWER	230 V, 3 Ph
WET WELL LINING/COATING	SUNSHIELD WATERPROOFING
ACCESS HATCH LOADING CRITERIA	PEDESTRIAN FLOODTIGHT

DISCLAIMERS, INCLUDING BUT NOT LIMITED TO:

- 1) Elevations provided by others. Changes greater than 0.1' require engineer approval of concrete excavation. These mechanical drawings are not intended for setting of precast concrete excavation.
- 2) Pump station design characteristics such as, but not limited to, inflow rate, on-
- 3) Purchasing agent must verify pump station complies with engineering plan.
- 4) Site assembly required. Purchasing agent is responsible for assembly.
- 5) Location of control panel must be disclosed to Jensen Precast.

PROJECT	RANCHO VISTA MECHANICAL DETAIL	<p>JENSEN ENGINEERING SYSTEMS</p> <p>825 STONER HOLLOW DR. SPARKS, NV 89411 Jensen-Engineering@csystems.com 935-458-1600</p>	
DATE	12/20/17		
DESIGNED BY	CAP	DATE	2/4/2

Dimensions

TP53M35/4/3FM



Wet well installation with coupling kit 3" ANSI
 Dimensions in mm [inch], letters see table

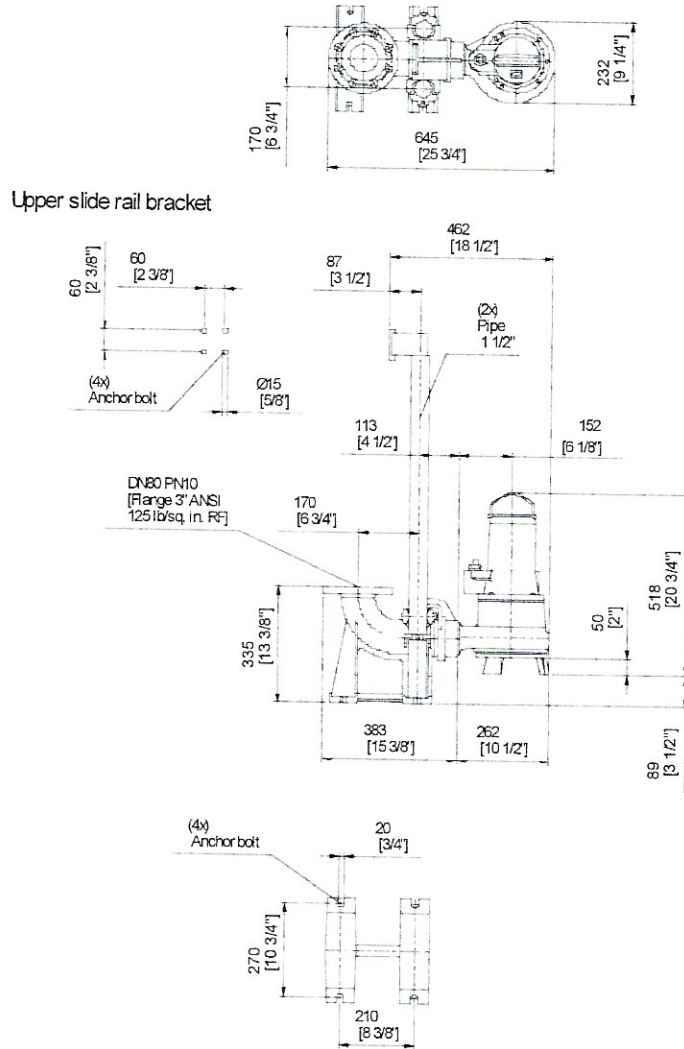

Table Dimensions (inch)

--	--	--	--

Project	Project no.:	Created by:	Page: 3	Date: 2017-05-16
---------	--------------	-------------	---------	------------------

APPENDIX B

ADDITIONAL PICTURES

CITY OF SAN JUAN BAUTISTA – RANCHO VISTA SEWER LIFT STATION COMPLIANCE REVIEW

Appendix B Additional Pictures

Appendix B ADDITIONAL PICTURES



Figure B.1 – Inside Door Of Control Panel

Appendix B Additional Pictures

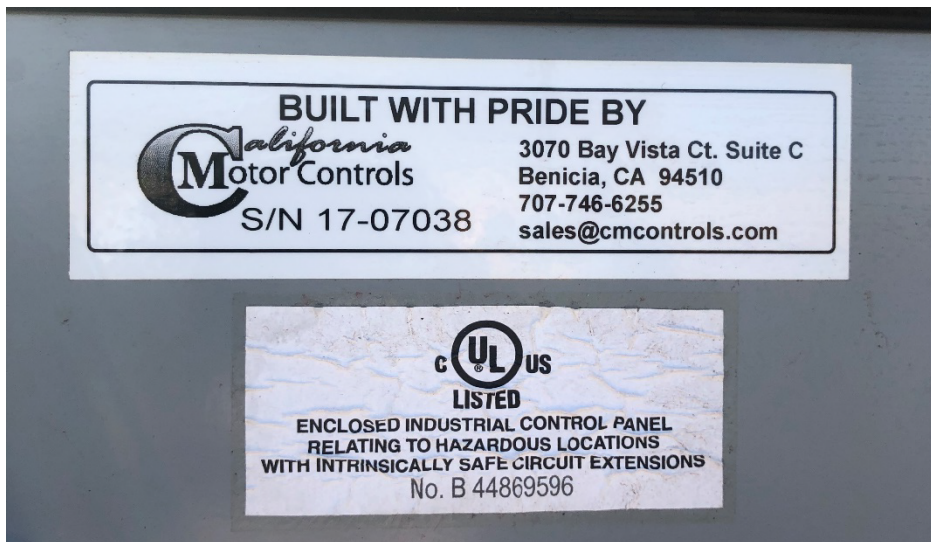

Figure B.2 – Control Panel Builder Information

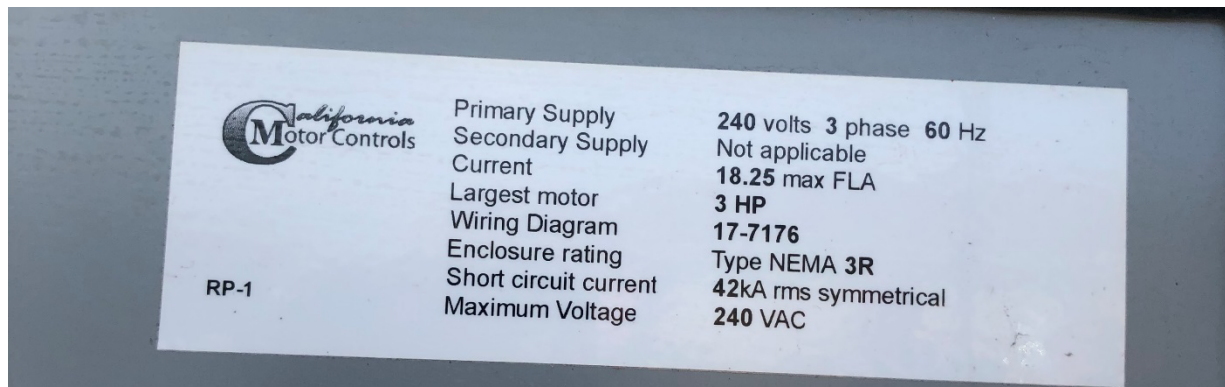

Figure B.3 – Control Panel Information

CITY OF SAN JUAN BAUTISTA – RANCHO VISTA SEWER LIFT STATION COMPLIANCE REVIEW

Appendix B Additional Pictures

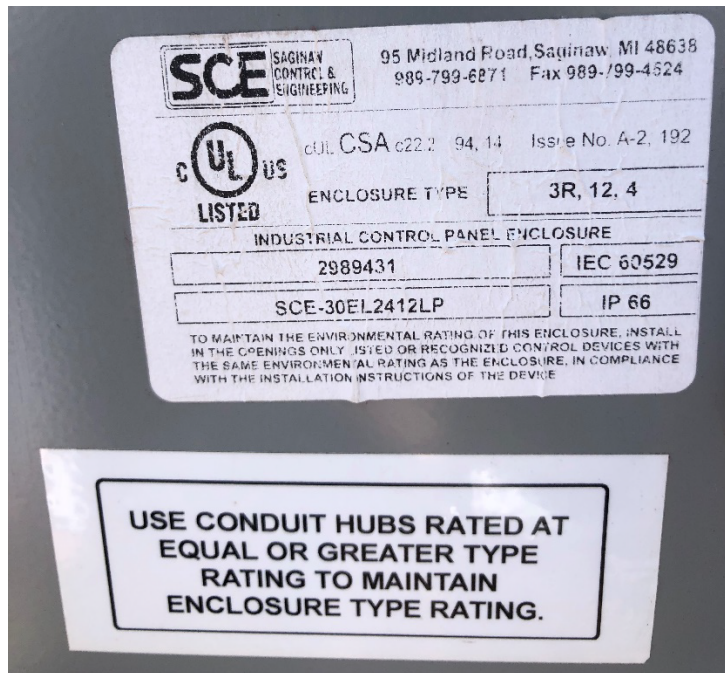

Figure B.4 – Control Panel Enclosure Information

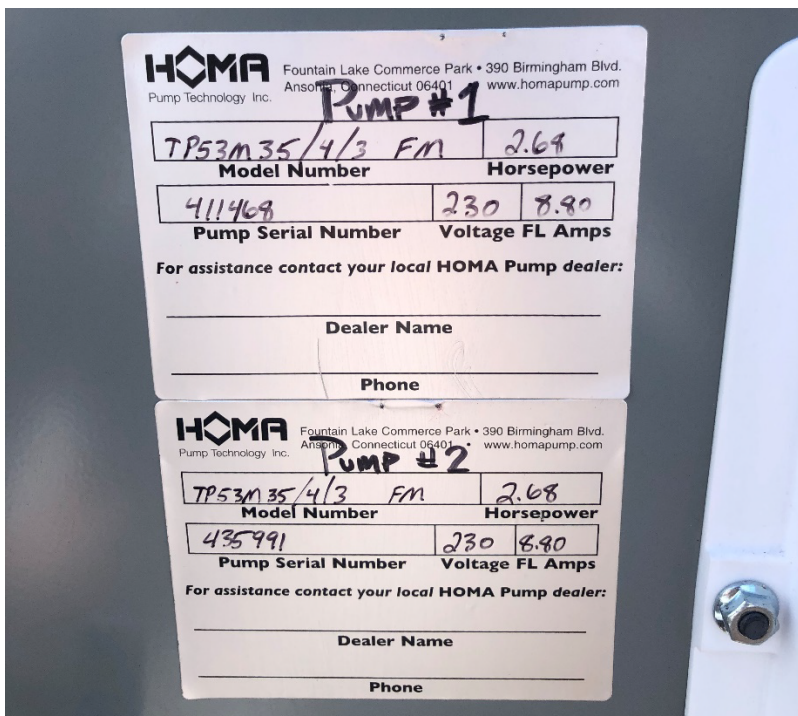

Figure B.5 – HOMA Pump Information

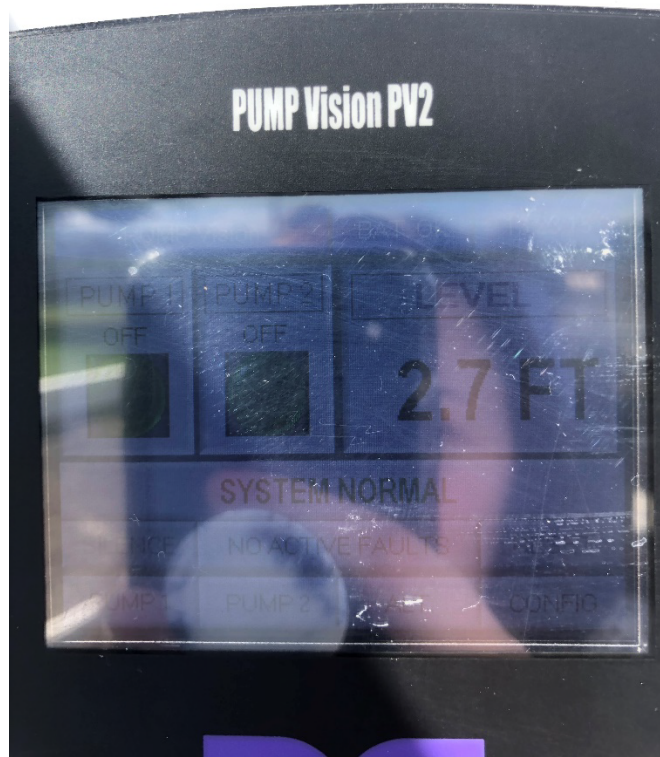

Figure B.6 – Control Panel Screen