

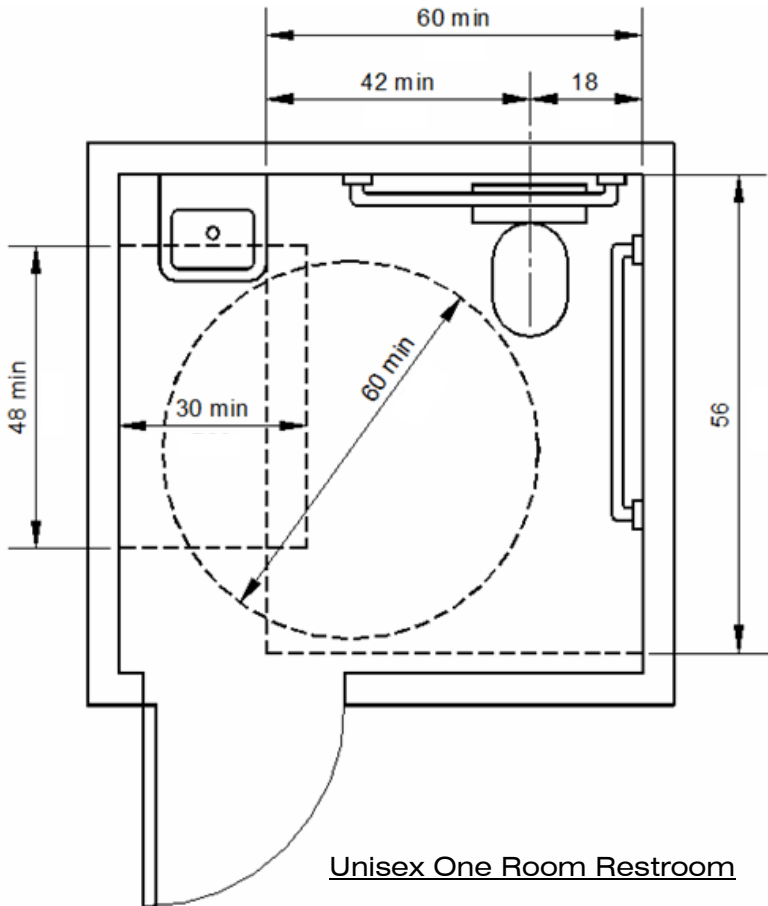

Waterloo Building Department
 715 Mulberry Street
 Waterloo IA 50703
 319-291-4319
www.cityofwaterlooiowa.com

ADA RESTROOM

Individual Use Unisex



This handout depicts ADA requirements for a single use commercial restroom. The Americans with Disability Act has further requirements for multiple use restrooms that can be obtained from the Waterloo Building Department. For written requirements of the rules depicted here, see the reverse side of this handout.

ADA Grab Bar Requirements

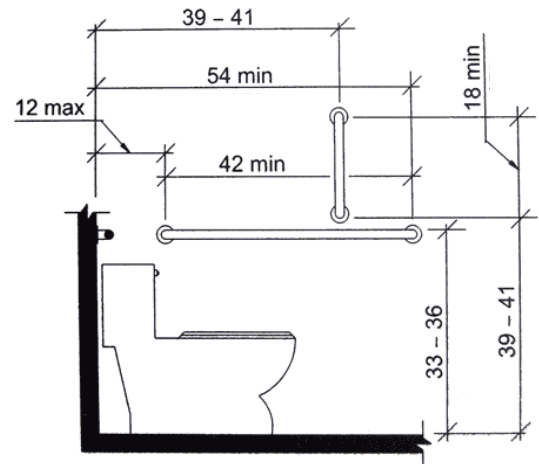

Side Wall Grab Bar

ADA Sink Requirements

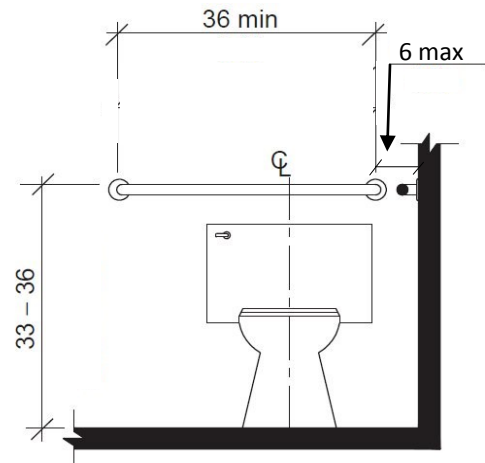
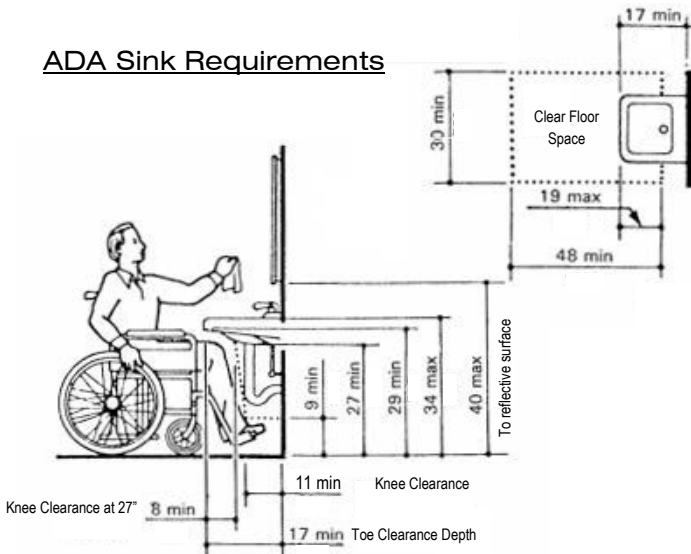

Rear Wall Grab Bar

This brochure is intended to explain some of the requirements for ADA Restrooms. If you have further questions, please contact the Waterloo Building Department.

DOOR. Doors shall not swing into the clear floor space or clearance for any fixture. An exception for this rule is allowable where a clear floor space of 48" minimum in length and 30" minimum in width exists outside the arc of the door. Clear width of the door must be 32" minimum. Door hardware such as handles, pulls, latches, locks and other operable parts shall have a shape that is easy to grasp with one hand and doesn't not require tight grasping, pinching or twisting of the wrist to operate. Operable parts of such hardware shall be located 34" - 48" above the floor.

TURNING SPACE. The Turning Space shall be a clear circular floor space with a 60" minimum diameter. The turning space shall be permitted to include knee and toe clearance.

WATER CLOSET. The Water Closet (toilet) shall be located with a wall to the rear and a wall to one side. The centerline of the water closet shall be 16" minimum to 18" maximum from the side wall. Clearance around a water closet of 60" minimum measured perpendicular from the sidewall and 56" minimum measured perpendicular from the rear wall shall be provided. This clearance is permitted to overlap the water closet, grab bars, paper dispensers, turning space and clear floor space at other fixtures. Other fixtures or obstructions are not allowable in this clearance area. The height of water closet seats shall be 17" minimum and 19" maximum above the floor measured to the top of the seat. Flush controls shall be operable with one hand, and installed 36" maximum above the floor and located on the open side of the water closet.

GRAB BARS. Grab bars shall be provided on the rear wall and on the side wall closest to the water closet. Side Wall Grab Bars shall be 42" minimum in length, located 12" maximum from the rear wall and extending 54" from the rear wall. In addition, a vertical grab bar 18" minimum in length shall be mounted with the bottom of the bar located between 39" and 41" above the floor and with the center line of the bar located between 39" and 41" from the rear wall. Rear Wall Grab Bars shall be 36" minimum in length, and extend from the centerline of the water closet 12" minimum on the side closest to the side wall and 24" minimum on the transfer side. Spacing between the wall and the grab bar shall be 1 1/2". Grab Bars, fasteners and supporting structure need to withstand 250 lbs of vertical or horizontal pressure.

LAVATORIES AND SINKS. The front height of lavatories and sinks shall be 34" maximum above the floor measured to the higher of the rim or counter surface. Faucets shall be operable with one hand and shall not require tight grasping, pinching or twisting of the wrist. Exposed water supply and drain pipes under lavatories and sinks shall be insulated or otherwise configured to protect against contact. There shall be no sharp or abrasive surfaces under lavatories and sinks. The space below the sink between the floor and 9" vertical, toe clearance of 17" deep and 30" wide is required. Space between 9" and 27" above the floor, 11" deep at 9" above the floor and 8" deep at 27" above the floor and 30" wide is required for knee clearance. Also there must be a Clear Floor Space in front of the sink positioned for forward approach shall be provided with 48" minimum approach length and 30" minimum width.

MIRROR. Mirrors located above lavatories, sinks or counters shall be mounted with the bottom edge of the reflecting surface 40" maximum above the floor. Mirrors not located above lavatories, sinks or counters shall be mounted with the bottom edge of the reflective surface 35" maximum above the floor.

FLOOR, WALL BASES AND WALLS. Toilet room floor finish materials shall have a smooth, hard, nonabsorbent surface. The intersection between the floor and the walls shall have a vertical nonabsorbent base, such as ceramic tile or vinyl, that extends upward a minimum of 4" onto walls. Walls and partitions within 2' of sinks, urinals and water closets shall have a smooth, hard, non-absorbent surface to a height of not less than 4' above the floor. Materials on these walls shall be of a type that is not adversely affected by moisture. Grab bars, paper dispensers, soap dispensers and other items provided on walls shall be installed and sealed to protect structural elements from moisture.